

NFC reader for payment, consumer and industrial applications

Datasheet - production data

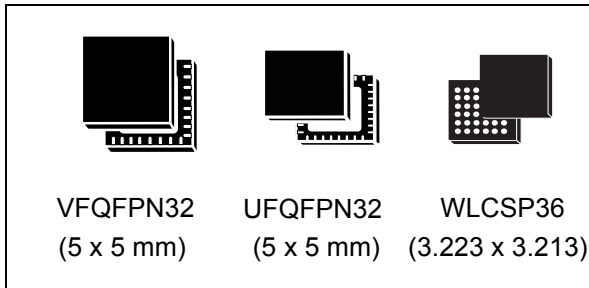

Features

- Operating modes
 - Reader/writer
 - Card emulation
 - Active and passive peer to peer
- RF communication
 - EMVCo[®] PCD L1 v3.2a analog and digital compliant
 - NFC-A/ISO14443A up to 848 kbit/s
 - NFC-B/ISO14443B up to 848 kbit/s
 - NFC-F/FeliCa[™] up to 424 kbit/s
 - NFC-V/ISO15693 up to 53 kbit/s
 - NFC-A/ISO14443A (106 kbit/s) and NFC-F/FeliCa[™] (212/424 kbit/s) card emulation
 - Active and passive peer to peer initiator and target modes, up to 424 kbit/s
 - Low-level modes to implement MIFARE Classic[®]-compliant or other custom protocols
- Key characteristics
 - Dynamic power output (DPO) controls the field strength to stay within given limits
 - Active wave shaping (AWS) reduces over- and undershoots
 - Noise suppression receiver (NSR) allows reception in a noisy environment
 - Automatic antenna tuning (AAT) via variable capacitor
- Integrated EMVCo[®] PCD L1 v3.2a-compliant EMD handling
- Automatic gain control and squelch feature to maximize SNR
- Low-power NFC active and passive target modes
- Adjustable ASK modulation depth, from 0 to 82%
- Integrated regulators to boost system PSRR
- AM/PM and I/Q demodulator with baseband channel summation or automatic channel selection
- Possibility to drive two independent single ended antennas
- Measurement of antenna voltage amplitude and phase, RSSI, on-chip supply, and regulated voltages
- External communication interfaces
 - 512-byte FIFO
 - Serial peripheral interface (SPI) up to 10 Mbit/s
 - I2C with up to 400 kbit/s in Fast-mode, 1 Mbit/s in Fast-mode Plus, and 3.4 Mbit/s in High-speed mode
- Electrical characteristics
 - Wide supply voltage and ambient temperature range (2.6 to 5.5 V from -40 °C to +105 °C, 2.4 to 5.5 V from -20 °C to +105 °C)
 - Wide peripheral communication supply range from 1.65 to 5.5 V
 - Quartz oscillator capable of operating with 27.12 MHz crystal with fast startup

Contents

1	Applications	11
2	Description	12
2.1	System diagram	13
2.2	Block diagram	15
2.2.1	Transmitter	15
2.2.2	Receiver	16
2.2.3	Phase and amplitude detector	16
2.2.4	Automatic antenna tuning (AAT)	16
2.2.5	A/D converter	16
2.2.6	External field detector	16
2.2.7	Quartz crystal oscillator	17
2.2.8	Power supply regulators	17
2.2.9	POR and bias	17
2.2.10	RC oscillator and Wake-up timer	17
2.2.11	TX encoding	17
2.2.12	RX decoding	17
2.2.13	FIFO	18
2.2.14	Control logic	18
2.2.15	Host interface	18
2.2.16	Passive target memory	18
2.2.17	P2RAM	18
3	Pin and signal description	19
4	Application information	23
4.1	Power-on sequence	23
4.2	Operating modes	23
4.2.1	Transmitter	24
4.2.2	Receiver	25
4.2.3	Antenna tuning	30
4.2.4	Wake-up mode	31
4.2.5	Quartz crystal oscillator	32
4.2.6	Timers	32

4.2.7	A/D converter	35
4.2.8	Phase and amplitude detector	35
4.2.9	External field detector	36
4.2.10	Power supply system	37
4.2.11	Overshoot / undershoot protection	40
4.2.12	Active wave shaping	41
4.2.13	Reader operation	45
4.2.14	Listen mode	46
4.3	Communication with an external microcontroller	49
4.3.1	Interrupt interface	49
4.3.2	Communication interface selection	51
4.3.3	Serial peripheral interface (SPI)	51
4.3.4	I2C interface	56
4.4	Direct commands	60
4.4.1	Set default	62
4.4.2	Stop all activities	62
4.4.3	Clear FIFO	62
4.4.4	Transmit commands	63
4.4.5	NFC field ON commands	63
4.4.6	Mask receive data and Unmask receive data	65
4.4.7	Change AM modulation state	65
4.4.8	Measure amplitude	65
4.4.9	Reset RX gain	65
4.4.10	Adjust regulators	65
4.4.11	Measure phase	66
4.4.12	Clear RSSI	66
4.4.13	Transparent mode	66
4.4.14	Measure power supply	66
4.4.15	Trigger RC calibration	67
4.4.16	Test access	67
4.5	Registers	68
4.5.1	IO configuration register 1	72
4.5.2	IO configuration register 2	73
4.5.3	Operation control register	74
4.5.4	Mode definition register	75
4.5.5	Bit rate definition register	77
4.5.6	ISO14443A and NFC 106kb/s settings register	78

4.5.7	ISO14443B settings register 1	79
4.5.8	ISO14443B and FeliCa settings register	80
4.5.9	NFCIP-1 passive target definition register	81
4.5.10	Stream mode definition register	82
4.5.11	Auxiliary definition register	83
4.5.12	EMD suppression configuration register	84
4.5.13	Subcarrier start timer register	85
4.5.14	Receiver configuration register 1	86
4.5.15	Receiver configuration register 2	87
4.5.16	Receiver configuration register 3	88
4.5.17	Receiver configuration register 4	88
4.5.18	P2P receiver configuration register 1	89
4.5.19	Correlator configuration register 1	90
4.5.20	Correlator configuration register 2	91
4.5.21	Mask receive timer register	92
4.5.22	No-response timer register 1	93
4.5.23	No-response timer register 2	93
4.5.24	Timer and EMV control register	94
4.5.25	General purpose timer register 1	95
4.5.26	General purpose timer register 2	95
4.5.27	PPON2 field waiting register	96
4.5.28	Squelch timer register	97
4.5.29	NFC field on guard timer register	97
4.5.30	Mask main interrupt register	98
4.5.31	Mask timer and NFC interrupt register	98
4.5.32	Mask error and wake-up interrupt register	99
4.5.33	Mask passive target interrupt register	99
4.5.34	Main interrupt register	100
4.5.35	Timer and NFC interrupt register	101
4.5.36	Error and wake-up interrupt register	102
4.5.37	Passive target interrupt register	103
4.5.38	FIFO status register 1	104
4.5.39	FIFO status register 2	104
4.5.40	Collision display register	105
4.5.41	Passive target display register	106
4.5.42	Number of transmitted bytes register 1	107
4.5.43	Number of transmitted bytes register 2	107

4.5.44	Bit rate detection display register	108
4.5.45	A/D converter output register	109
4.5.46	Antenna tuning control register 1	110
4.5.47	Antenna tuning control register 2	110
4.5.48	TX driver register	111
4.5.49	Auxiliary modulation setting register	113
4.5.50	Passive target modulation register	114
4.5.51	TX driver timing register	115
4.5.52	External field detector activation threshold register	116
4.5.53	Resistive AM modulation register	117
4.5.54	External field detector deactivation threshold register	119
4.5.55	TX driver timing display register	121
4.5.56	Regulator voltage control register	122
4.5.57	Regulator display register	123
4.5.58	RSSI display register	124
4.5.59	Gain reduction state register	125
4.5.60	AWS Config 1 register	126
4.5.61	AWS Config 2 register	127
4.5.62	Auxiliary display register	128
4.5.63	Overshoot protection configuration register 1	129
4.5.64	Overshoot protection configuration register 2	129
4.5.65	Undershoot protection configuration register 1	130
4.5.66	Undershoot protection configuration register 2	131
4.5.67	Wake-up timer control register	132
4.5.68	Amplitude measurement configuration register	133
4.5.69	Amplitude measurement reference register	133
4.5.70	AWS time 1 register	134
4.5.71	AWS time 2 register	134
4.5.72	AWS time 3 register	135
4.5.73	AWS time 4 register	135
4.5.74	AWS time 5 register	136
4.5.75	AWS time 6 register	136
4.5.76	Amplitude measurement auto-averaging display register	137
4.5.77	Amplitude measurement display register	137
4.5.78	Phase measurement configuration register	138
4.5.79	Phase measurement reference register	138
4.5.80	Phase measurement auto-averaging display register	139

4.5.81	Phase measurement display register	139
4.5.82	Measurement TX delay	140
4.5.83	IC identity register	142
5	Electrical characteristics	143
5.1	Absolute maximum ratings	143
5.2	Operating conditions	144
5.3	DC/AC characteristics for digital inputs and outputs	145
5.4	Electrical specifications	146
5.5	SPI interface characteristics	149
5.6	I2C interface characteristics	151
6	Package information	156
6.1	VFQFPN32 package information	156
6.2	UFQFPN32 package information (A0B8)	158
6.3	WLCSP36 package information	162
7	Ordering information	164
8	Revision history	165

List of tables

Table 1.	List of features	11
Table 2.	ST25R3916B - VFQFPN32, UFQFPN32 and WLCSP36 pin assignment	20
Table 3.	ST25R3917B/ST25R3919B VFQFPN32 and UFQFPN32 pin assignment	21
Table 4.	RX channel selection	26
Table 5.	Low-pass control	27
Table 6.	First and third zero setting	28
Table 7.	Typical preset values for slow, medium and fast transients in OOK and ASK	42
Table 8.	PT_Memory address space	47
Table 9.	NFC-212/424k SENS_RES format	48
Table 10.	IRQ output	49
Table 11.	Serial data interface (4-wire interface) signal lines	51
Table 12.	SPI operation modes	52
Table 13.	I2C interface and interrupt signal lines	57
Table 14.	List of direct commands	60
Table 15.	Timing parameters of NFC field ON commands	64
Table 16.	Analog test and observation register 1	67
Table 17.	Test access register - Signal selection of TAD1 and TAD2 pins	68
Table 18.	List of registers - Space A	69
Table 19.	List of registers - Space B	70
Table 20.	IO configuration register 1	72
Table 21.	IO configuration register 2	73
Table 22.	Operation control register	74
Table 23.	Mode definition register	75
Table 24.	Initiator operation modes	75
Table 25.	Target operation modes	75
Table 26.	Bit rate definition register	77
Table 27.	Bit rate coding	77
Table 28.	ISO14443A and NFC 106kb/s settings register	78
Table 29.	Modulation pulse width	78
Table 30.	ISO14443B settings register 1	79
Table 31.	ISO14443B and FeliCa settings register	80
Table 32.	Minimum TR1 codings	80
Table 33.	NFCIP-1 passive target definition register	81
Table 34.	Stream mode definition register	82
Table 35.	Sub-carrier frequency definition for Sub-Carrier stream mode	82
Table 36.	Definition of time period for Stream mode Tx modulator control	82
Table 37.	Auxiliary definition register	83
Table 38.	EMD suppression configuration register	84
Table 39.	Subcarrier start timer register	85
Table 40.	Receiver configuration register 1	86
Table 41.	Receiver configuration register 2	87
Table 42.	Receiver configuration register 3	88
Table 43.	Receiver configuration register 4	88
Table 44.	P2P receiver configuration register 1	89
Table 45.	OOK threshold level settings	89
Table 46.	Correlator configuration register 1	90
Table 47.	Correlator configuration register 2	91
Table 48.	Mask receive timer register	92

Table 49.	No-response timer register 1	93
Table 50.	No-response timer register 2	93
Table 51.	Timer and EMV control register	94
Table 52.	Trigger sources	94
Table 53.	General purpose timer register 1	95
Table 54.	General purpose timer register 2	95
Table 55.	PPON2 field waiting register	96
Table 56.	Squelch timer register	97
Table 57.	NFC field on guard timer register	97
Table 58.	Mask main interrupt register	98
Table 59.	Mask timer and NFC interrupt register	98
Table 60.	Mask error and wake-up interrupt register	99
Table 61.	Mask passive target interrupt register	99
Table 62.	Main interrupt register	100
Table 63.	Timer and NFC interrupt register	101
Table 64.	Error and wake-up interrupt register	102
Table 65.	Passive target interrupt register	103
Table 66.	FIFO status register 1	104
Table 67.	FIFO status register 2	104
Table 68.	Collision display register	105
Table 69.	Passive target display register	106
Table 70.	Number of transmitted bytes register 1	107
Table 71.	Number of transmitted bytes register 2	107
Table 72.	Bit rate detection display register	108
Table 73.	A/D converter output register	109
Table 74.	Antenna tuning control register 1	110
Table 75.	Antenna tuning control register 2	110
Table 76.	TX driver register	111
Table 77.	AM modulation index	111
Table 78.	RFO driver resistance	112
Table 79.	Auxiliary modulation setting register	113
Table 80.	Passive target modulation register	114
Table 81.	Passive target modulated and unmodulated state driver output resistance	114
Table 82.	TX driver timing register	115
Table 83.	External field detector activation threshold register	116
Table 84.	Resistive AM modulation register	117
Table 85.	Resistive AM modulated state driver output resistance	117
Table 86.	External field detector deactivation threshold register	119
Table 87.	Peer detection threshold as seen on RF11 input	120
Table 88.	Collision avoidance threshold as seen on RF11 input	120
Table 89.	TX driver timing display register	121
Table 90.	Regulator voltage control register	122
Table 91.	Regulator display register	123
Table 92.	Regulated voltages	123
Table 93.	RSSI display register	124
Table 94.	RSSI	124
Table 95.	Gain reduction state register	125
Table 96.	AWS configuration 1	126
Table 97.	AWS configuration 2	127
Table 98.	Auxiliary display register	128
Table 99.	Overshoot protection configuration register 1	129
Table 100.	Overshoot protection configuration register 2	129

Table 101.	Undershoot protection configuration register 1	130
Table 102.	Undershoot protection configuration register 2	131
Table 103.	Wake-up timer control register	132
Table 104.	Typical wake-up time	132
Table 105.	Amplitude measurement configuration register	133
Table 106.	Amplitude measurement reference register	133
Table 107.	AWS time 1 register	134
Table 108.	AWS time 2 register	134
Table 109.	AWS time 3 register	135
Table 110.	AWS time 4 register	135
Table 111.	AWS time 5 register	136
Table 112.	AWS time 6 register	136
Table 113.	Amplitude measurement auto-averaging display register	137
Table 114.	Amplitude measurement display register	137
Table 115.	Phase measurement configuration register	138
Table 116.	Phase measurement reference register	138
Table 117.	Phase measurement auto-averaging display register	139
Table 118.	Phase measurement display register	139
Table 119.	Measurement TX delay	140
Table 120.	Wake-up time and wake-up pulse prolongation	141
Table 121.	IC identity register	142
Table 122.	Absolute maximum ratings	143
Table 123.	Operating conditions	144
Table 124.	Characteristics of CMOS I/Os	145
Table 125.	ST25R39xxB electrical characteristics (VDD = 3.3 V)	146
Table 126.	ST25R39xxB electrical characteristics (VDD = 5.5 V)	147
Table 127.	ST25R39xxB electrical characteristics (VDD = 2.4 V)	148
Table 128.	SPI characteristics (5 MHz)	149
Table 129.	SPI characteristics (5 MHz < 1/TSCLK < 10 MHz)	149
Table 130.	AC measurement conditions	151
Table 131.	AC measurement conditions - I2C configuration	151
Table 132.	Input parameters	151
Table 133.	DC characteristics	151
Table 134.	100 kHz AC characteristics	152
Table 135.	400 kHz AC characteristics	152
Table 136.	1 MHz AC characteristics	153
Table 137.	3.4 MHz AC characteristics	153
Table 138.	VFQFPN32 - Mechanical data	156
Table 139.	UFQFPN32 - Mechanical data	159
Table 140.	Tolerance of form and position	159
Table 141.	WLCSP36 - Mechanical data	162
Table 142.	Ordering information scheme	164
Table 143.	Document revision history	165

List of figures

Figure 1.	Minimum system configuration - Single sided antenna driving	13
Figure 2.	Minimum system configuration - Differential antenna driving	14
Figure 3.	ST25R39xxB block diagram	15
Figure 4.	ST25R3916B QFN32 pinout (top view)	19
Figure 5.	ST25R3917B and ST25R3919B QFN32 pinout (top view)	19
Figure 6.	ST25R3916B WLCSP36 (top view)	20
Figure 7.	Receiver block diagram	26
Figure 8.	Phase detector inputs and output in case of 90° phase shift	36
Figure 9.	Phase detector inputs and output in case of 135° phase shift	36
Figure 10.	ST25R39xxB power supply system	38
Figure 11.	AWS mechanism	41
Figure 12.	Bit and timing relation for OOK waveform	43
Figure 13.	Bit and timing relation for ASK waveform	44
Figure 14.	Exchange of signals with a microcontroller	51
Figure 15.	SPI communication: writing a single byte	53
Figure 16.	SPI communication: writing multiple bytes	53
Figure 17.	SPI communication: reading a single byte	54
Figure 18.	SPI communication: FIFO loading	54
Figure 19.	SPI communication: FIFO reading	55
Figure 20.	SPI communication: direct command	56
Figure 21.	SPI communication: direct command chaining	56
Figure 22.	Writing a single register	57
Figure 23.	Writing register data with auto-incrementing address	57
Figure 24.	Reading a single byte from a register	58
Figure 25.	FIFO load	58
Figure 26.	FIFO read	59
Figure 27.	Sending a direct command	59
Figure 28.	Read and Write mode for register space-B access	59
Figure 29.	I2C controller reads target immediately after the first byte	60
Figure 30.	Direct command NFC initial field ON	64
Figure 31.	Direct command NFC response field ON	64
Figure 32.	SPI timing diagram - General operation	150
Figure 33.	SPI timing diagram - Read operation	150
Figure 34.	RPmin vs. VDD, fc = 3.4 MHz	154
Figure 35.	Maximum Rbus value vs. bus parasitic capacitance, fc = 3.4 MHz	154
Figure 36.	I2C AC waveforms	155
Figure 37.	I2C AC measurements	155
Figure 38.	VFQFPN32 - Outline	156
Figure 39.	VFQFPN32 - Footprint example	157
Figure 40.	UFQFPN32 - Outline	158
Figure 41.	UFQFPN32 - Footprint example	161
Figure 42.	WLCSP36 - Outline	162
Figure 43.	WLCSP36 - Footprint example	163

1 Applications

The ST25R3916B, ST25R3917B and ST25R3919B devices are suitable for a wide range of NFC and HF RFID applications, among them

- NFC Forum compliant NFC universal device
- EMVCo PCD L1 v3.2a compliant contactless payment terminal
- ISO14443 and ISO15693 compliant general purpose NFC device
- FeliCa™ reader / writer
- Support all five NFC Forum Tag types in reader mode
- Support all common proprietary protocols, such as Kovio, CTS, B'.

The main differences between the two devices are detailed in [Table 1](#).

Table 1. List of features

Feature	ST25R3916B	ST25R3917B	ST25R3919B
ISO/IEC 14443 Type-A	Yes		
ISO/IEC 14443 Type-B	Yes		
ISO/IEC 15693	Yes		
FeliCa™	Yes		No
NFC Tag read support	NFC Type 1 Tag NFC Type 2 Tag NFC Type 3 Tag NFC Type 4 Tag NFC Type 5 Tag		NFC Type 1 Tag NFC Type 2 Tag - NFC Type 4 Tag NFC Type 5 Tag
ISO/IEC 18092 Passive Initiator mode	Yes		No
ISO/IEC 18092 Passive Target mode	Yes	No	No
ISO/IEC 18092 Active Initiator and Target mode	Yes	No	No
Automatic antenna tuning (AAT)	Yes	No	No
Card emulation	Yes	No	No
Inductive sensor wakeup	Yes		

2 Description

The ST25R3916B, ST25R3917B, and ST25R3919B (hereafter referred to as ST25R39xxB) are high-performance NFC universal devices. They support NFC initiator, NFC target, NFC reader, and NFC card emulation modes when applicable.

Designed to be compliant with EMVCo PCD L1 3.2a analog and digital, these devices are optimized for POS terminal applications. They enable fast EMVCo certification cycles, even under harsh conditions, with antenna around noisy LCD displays.

The ST25R3916B device includes an advanced analog front end (AFE) and a highly integrated data framing system for ISO18092 passive and active initiator, ISO18092 passive and active target, NFC-A/B (ISO14443A/B) reader including higher bit rates, NFC-F (FeliCa™) reader, NFC-V (ISO15693) reader up to 53 kbps, and NFC-A / NFC-F card emulation. The ST25R3917B and ST25R3919B provides a reduced feature set compared to the ST25R3916B.

Special stream and transparent modes of the AFE and framing system is used to implement other custom protocols in reader or card emulation mode.

The ST25R39xxB feature high RF output power to directly drive antennas at high efficiency.

The ST25R39xxB include additional features, making them incomparable for low-power applications. The presence of a card is detected by performing a measurement of the amplitude or phase of the antenna signal. They also contain a low power RC oscillator and wake-up timer to automatically wake-up the ST25R39xxB after a selected time period and check for a presence of a tag using one or more techniques of low power detection of card presence (phase or amplitude).

The ST25R39xxB are designed to operate from a wide power supply range (2.6 to 5.5 V from -40 °C to +105 °C, 2.4 to 5.5 V from -20 °C to +105 °C), and a wide peripheral IO voltage range (from 1.65 to 5.5 V).

Due to this combination of high RF output power, low-power modes and wide supply range these devices are perfectly suited for infrastructure NFC applications.

2.1 System diagram

Figure 1 and Figure 2 show the minimum system configuration for, respectively, single ended and differential antenna configurations. Both include the EMC filter.

Figure 1. Minimum system configuration - Single sided antenna driving

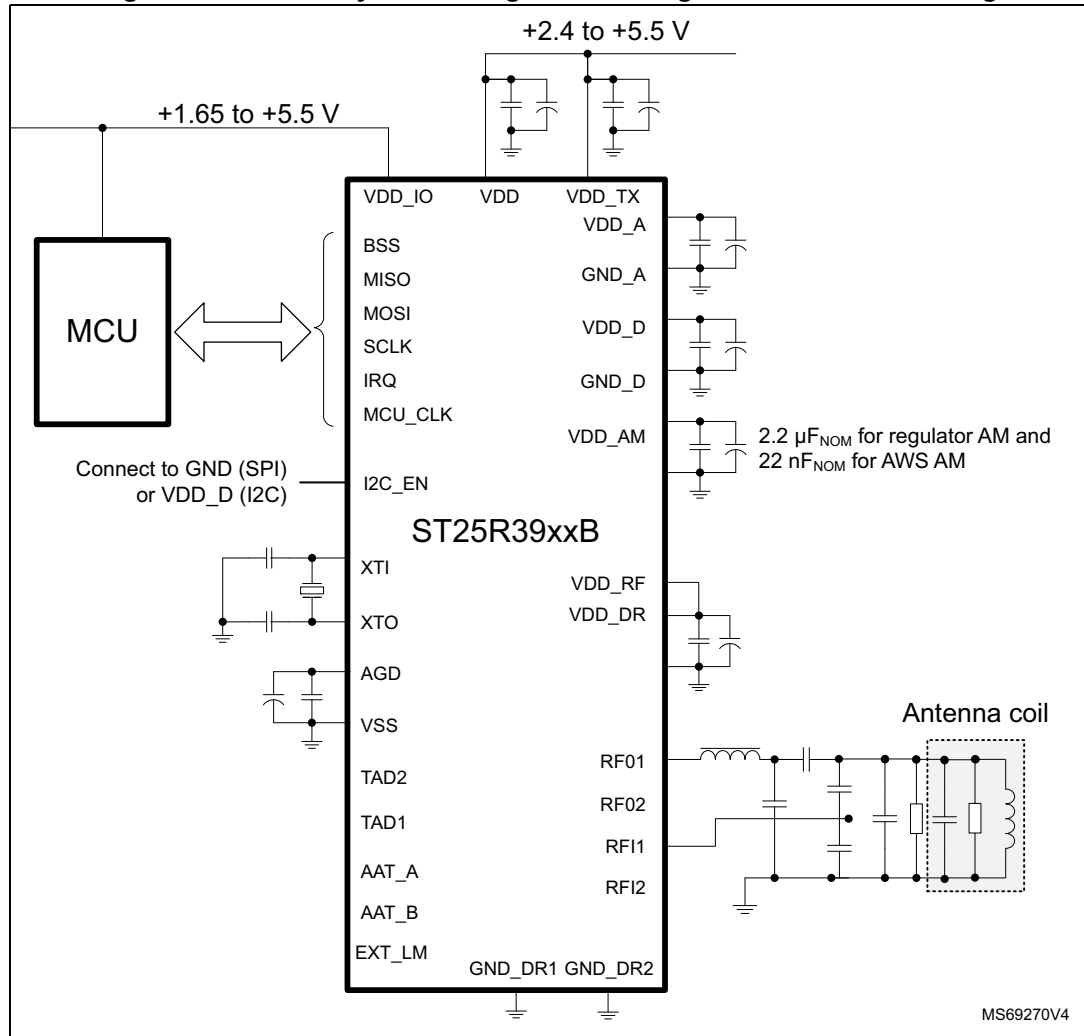

2.2.2 Receiver

The receiver detects card modulation superimposed on the 13.56 MHz carrier signal. The receiver consists of two receive chains that are built from a set of demodulators, followed by two gain and filtering stages and a final digitizer stage. The demodulators operate as AM/PM demodulator or as I/Q demodulator. The filter characteristics can be adjusted to match the selected RF mode and bit rate to optimize performance (subcarrier frequencies from 212 to 848 kHz are supported). Apart from the filter stage the receiver incorporates several other features (AGC, squelch) that enable reliable operation in noisy conditions.

The receiver is connected to the antenna via the pins RFI1 and RFI2. The output of the receiver is connected to the framing block that decodes the demodulated and digitized subcarrier signal.

2.2.3 Phase and amplitude detector

The phase detector measures the phase difference between the transmitter output signals (RFO1 and RFO2) and the receiver input signals (RFI1 and RFI2).

The amplitude detector measures the amplitude of the differential RF carrier signal between the receiver inputs RFI1 and RFI2. This differential amplitude signal is directly proportional to the amplitude of the RF signal on the antenna LC tank.

The phase- and amplitude detectors are used for several purposes:

- PM demodulation, by observing RFI1 and RFI2 phase variations (LF signal is fed to the receiver)
- Average phase difference between RFOx pins and RFIx pins, to check antenna tuning
- Measure amplitude of signal present on pins RFI1 and RFI2, proportional to the antenna voltage

2.2.4 Automatic antenna tuning (AAT)

The AAT block consists of two independent 8-bit D/A converters. These converters generate a programmable voltage (from 0 to 3.3 V) to control external variable capacitors.

2.2.5 A/D converter

The ST25R39xxB feature a built in A/D converter. Their input can be multiplexed from different sources and it is used for the diagnostic functions and the low power card detection. The result of the A/D conversion is stored in a register that can be read through the host interface.

2.2.6 External field detector

This is a low power block used in the active or passive target mode to detect the presence of an external RF field. It supports two different external field detection thresholds, namely Peer detection and Collision avoidance threshold.

The Peer detection threshold is used in the active and passive peer to peer modes to detect when the peer device turns on its RF field.

The Collision avoidance threshold is used to detect the presence of an external RF field during the RF collision avoidance procedure.

2.2.7 Quartz crystal oscillator

The quartz crystal oscillator operates with 27.12 MHz crystals. At start-up the transconductance of the oscillator is increased to achieve a fast start-up. Since the start-up time varies with crystal type, temperature and other parameters, the oscillator amplitude is observed and an interrupt is generated when stable oscillator operation is reached.

The oscillator block also provides a clock signal to the external microcontroller (MCU_CLK), according to the settings in the [IO configuration register 1](#).

2.2.8 Power supply regulators

The integrated power supply regulators ensures a high power supply rejection ratio (PSRR) for the complete system.

Three voltage regulators, one for the analog block, one for the digital block, and one for the RF output drivers, are available to decouple noise sources from the ST25R39xxB. A fourth voltage regulator generates the reference voltage for the analog receivers (AGDC, analog ground).

The RF output driver voltage regulator is configured automatically by the ST25R39xxB based on the systems power supply stability and RF output power (see [Section 4.4.10: Adjust regulators](#) for more details).

2.2.9 POR and bias

This block provides bias currents and reference voltages to all other blocks. It also incorporates a Power on Reset (POR) circuit that provides a reset at power-up and at low supply levels.

2.2.10 RC oscillator and Wake-up timer

The ST25R39xxB have two possibilities for low power detection of a card presence (phase measurement, amplitude measurement). The RC oscillator and the register configurable Wake-up timer are used to periodically trigger the card presence detection in the low power card detection modes.

2.2.11 TX encoding

This block encodes the transmit frames according to the selected RF mode and bit rate. The SOF (start of frame), EOF (end of frame), CRC and parity bits are generated automatically. The data to transmit are taken from the FIFO.

In Stream mode the framing is bypassed. The FIFO data directly defines the modulation data sent to the transmitter.

In Transparent mode, the framing and FIFO are bypassed, and the MOSI pin directly drives the modulation of the transmitter.

2.2.12 RX decoding

This block decodes received frames according to the selected RF mode and bitrate. The received data is written to the FIFO.

In Stream mode the framing is bypassed. The digitized subcarrier signal is directly stored in the FIFO.

In Transparent mode the framing and FIFO are bypassed. The digitized subcarrier signal directly drives the MISO pin.

2.2.13 FIFO

The ST25R39xxB contain a 512-byte FIFO. Depending on the direction of the data transfer, it contains either data which has been received or data which is to be transmitted.

In reader mode the ST25R39xxB can transmit frames of up to 8191 bytes length and receive frames of arbitrary length.

2.2.14 Control logic

The control logic contains I/O registers that define the operation of device.

2.2.15 Host interface

A 4-wire serial peripheral interface (SPI) and a 2-wire I2C interface are available to communicate with an external microcontroller. The pins for the SPI and the I2C interface are shared, and pin I2C_EN is used to select the active interface.

2.2.16 Passive target memory

The device contains a 48-byte RAM to store configuration data for the passive target and card emulation mode.

2.2.17 P2RAM

The P2RAM stores information on wafer number, die position, device subversion, and I2C address. The P2RAM is programmed during production.

3 Pin and signal description

Figure 4. ST25R3916B QFN32 pinout (top view)

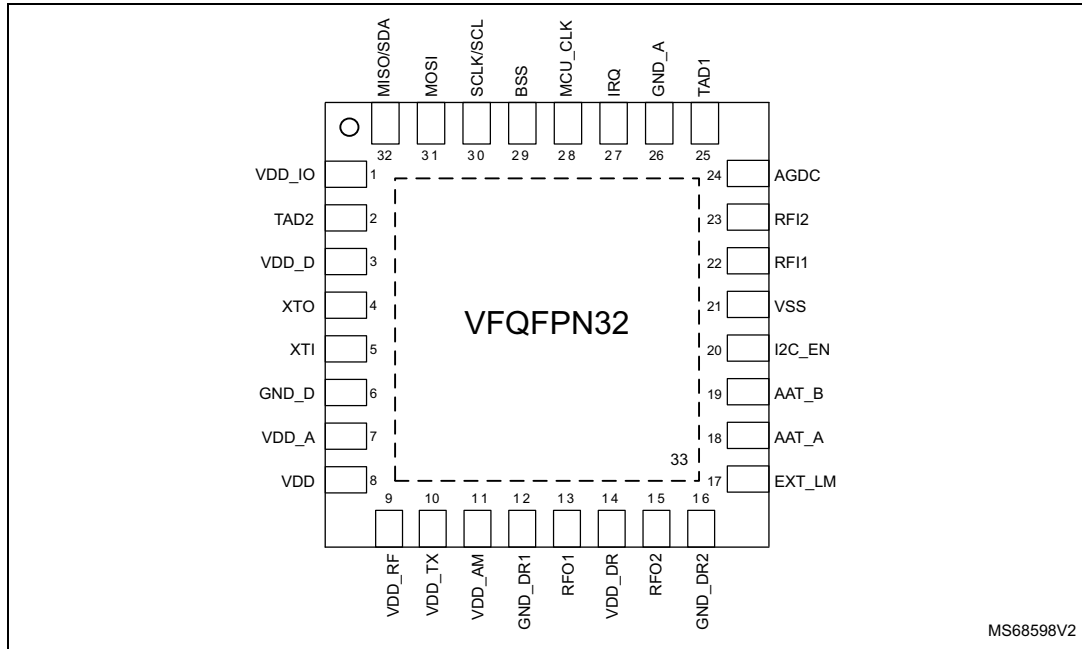

Figure 5. ST25R3917B and ST25R3919B QFN32 pinout (top view)

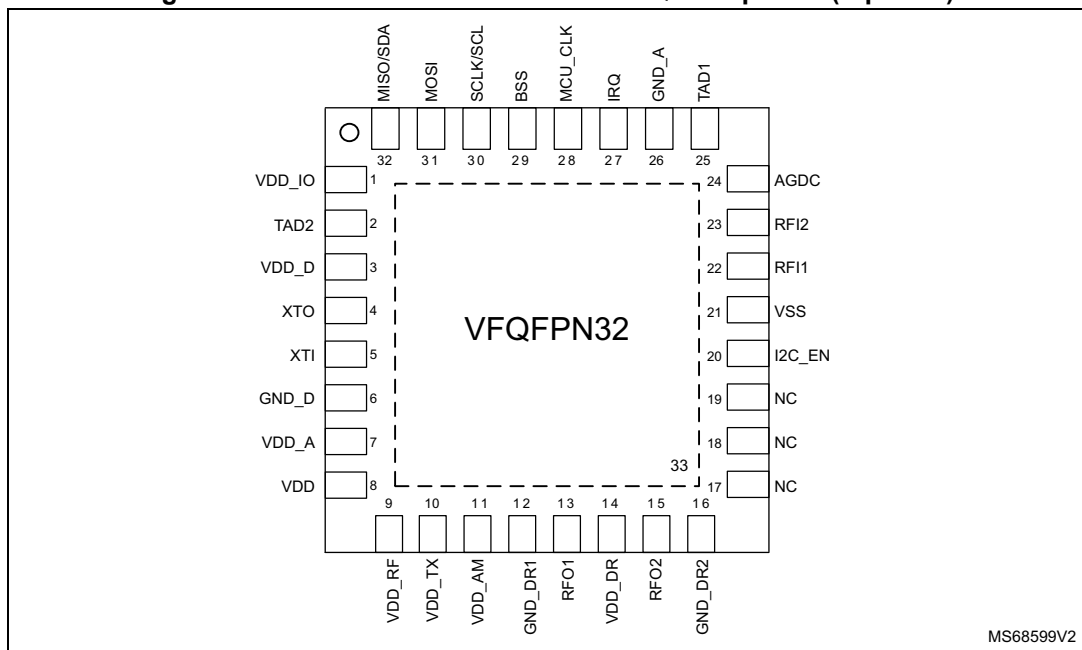

Figure 6. ST25R3916B WLCSP36 (top view)

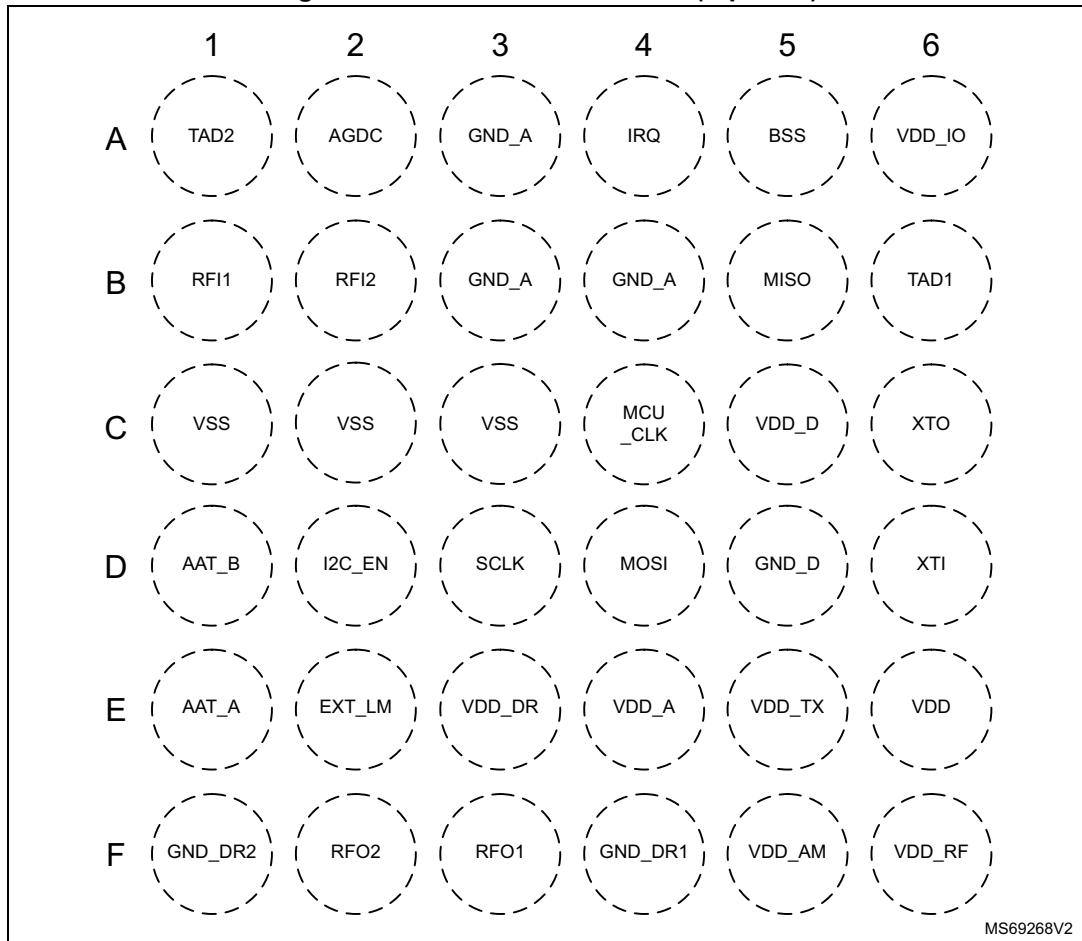

Table 2. ST25R3916B - VFQFPN32, UFQFPN32 and WLCSP36 pin assignment

VFQFPN32/ UFQFPN32	WLCSP	Name	Type ⁽¹⁾	Description
1	A6	VDD_IO	P	Positive supply for peripheral communication
2	B6	TAD1	AO	Test output 2
3	C5	VDD_D	AO	Digital supply regulator output
4	C6	XTO	AO	Crystal oscillator output
5	D6	XTI	AI/DI	Crystal oscillator input, in test mode used as digital input (clock)
6	D5	GND_D	P	Digital ground
7	E4	VDD_A	AO	Analog supply regulator output
8	E6	VDD	P	External positive supply
9	F6	VDD_RF	AO	Regulated driver supply for antenna drivers
10	E5	VDD_TX	P	External positive supply for the TX part
11	F5	VDD_AM	AO	Regulated driver supply for AM modulation

Table 2. ST25R3916B - VFQFPN32, UFQFPN32 and WLCSP36 pin assignment (continued)

VFQFPN32/ UFQFPN32	WLCSP	Name	Type ⁽¹⁾	Description
12	F4	GND_DR1	P	Antenna driver ground, including driver V _{SS}
13	F3	RFO1	AO	Antenna driver output
14	E3	VDD_DR	P	Antenna driver positive supply input
15	F2	RFO2	AO	Antenna driver output
16	F1	GND_DR2	P	Antenna driver ground, including driver V _{SS}
17	E2	EXT_LM	AO	External load modulation MOS gate driver
18	E1	AAT_A	AO	AAT tune voltage for variable capacitor AAT_A
19	D1	AAT_B	AO	AAT tune voltage for variable capacitor AAT_B
20	D2	I2C_EN	DI	I2C interface enable
21	C1, C2, C3	VSS	P	Ground, die substrate potential
22	B1	RFI1	AI	Receiver input
23	B2	RFI2	AI	Receiver input
24	A2	AGDC	AIO	Analog reference voltage
25	A1	TAD2	AIO	Test output 1
26	A3, B3, B4	GND_A	P	Analog ground
27	A4	IRQ	DO	Interrupt request output
28	C4	MCU_CLK	DO	Clock output for MCU
29	A5	BSS	DI	SPI enable (active low)
30	D3	SCLK	DI	SPI clock / I2C clock
31	D4	MOSI	DI	SPI data input
32	B5	MISO	DO_T	Serial peripheral interface data output / I2C data line
33	NA	NA	P	Thermal pad (GND)

1. P: Power supply pin
 AIO: analog I/O, AI: analog input, AO: analog output
 DI: digital input, DIPD: digital input with pull-down, DO: digital output, DO_T: digital output/tri-state, DIO: digital bidirectional.

Table 3. ST25R3917B/ST25R3919B VFQFPN32 and UFQFPN32 pin assignment

VFQFPN32/ UFQFPN32	Name	Type ⁽¹⁾	Description
1	VDD_IO	P	Positive supply for peripheral communication
2	TAD2	AO/DO	Test analog digital
3	VDD_D	AO	Digital supply regulator output
4	XTO	AO	Crystal oscillator output
5	XTI	AI/DI	Crystal oscillator input, in test mode used as digital input (clock)
6	GND_D	P	Digital ground

Table 3. ST25R3917B/ST25R3919B VFQFPN32 and UFQFPN32 pin assignment

VFQFPN32/ UFQFPN32	Name	Type ⁽¹⁾	Description
7	VDD_A	AO	Analog supply regulator output
8	VDD	P	External positive supply
9	VDD_RF	AO	Regulated driver supply for antenna drivers
10	VDD_TX	P	External positive supply for the TX part
11	VDD_AM	AO	Regulated driver supply for AM modulation
12	GND_DR1	P	Antenna driver ground, including driver V _{SS}
13	RFO1	AO	Antenna driver output
14	VDD_DR	P	Antenna driver positive supply input
15	RFO2	AO	Antenna driver output
16	GND_DR2	P	Antenna driver ground, including driver V _{SS}
17	NC	-	Pin must be not connected
18	NC	-	Pin must be not connected
19	NC	-	Pin must be not connected
20	I2C_EN	DI	I2C interface enable (VDD_D level)
21	VSS	P	Ground, die substrate potential
22	RFI1	AI	Receiver input
23	RFI2	AI	Receiver input
24	AGDC	AIO	Analog reference voltage
25	TAD1	AO/DO	Test analog digital
26	GND_A	P	Analog ground
27	IRQ	DO	Interrupt request output
28	MCU_CLK	DO	Clock output for MCU
29	BSS	DI	SPI enable (active low)
30	SCLK	DI	SPI clock / I2C clock
31	MOSI	DI	SPI data input
32	MISO	DO_T	Serial peripheral interface data output / I2C data line
33	NA	P	Thermal pad (GND)

1. P: Power supply pin
AIO: analog I/O, AI: analog input, AO: analog output, DI: digital input,
DIPD: digital input with pull-down, DO: digital output, DO_T: digital output/tri-state, DIO: digital bidirectional.

4 Application information

4.1 Power-on sequence

Once powered, the device enters the Power-down mode where the content of all registers is set to its default state.

The next steps are basic configurations of the IC:

1. The *IO configuration register 1* and *IO configuration register 2* must be properly configured.
2. The internal voltage regulators have to be configured. It is recommended to use direct command Adjust regulators to improve the system PSRR.
3. If AAT is used the tuning procedure must be performed.
4. After device power-on and direct command set default, release the direct command Trigger RC calibration.

After the sequence of events mentioned above the devices are ready to operate.

4.2 Operating modes

The ST25R39xxB operating mode is defined by the contents of the *Operation control register*. At power-on all its bits are set to 0, the ST25R39xxB are in Power-down mode. In this mode, the AFE static power consumption is minimized, as only the POR and part of the bias are active. The regulator itself is disabled.

The SPI/I2C is still functional in this mode and all required settings on the configuration registers can be done. The PT_memory and FIFO are not accessible in this mode.

Bit en (bit 7 of the *Operation control register*) is controlling the quartz crystal oscillator, regulators and AAT control output pins. When this bit is set, the device enters in Ready mode and the quartz crystal oscillator and regulators are enabled. An interrupt is sent to inform the microcontroller when the oscillator amplitude and frequency is stable. The PT_memory and FIFO are accessible in this mode.

The enable of the receiver and the transmitter block are separated, it is possible to operate one without switching on the other (control bits rx_en and tx_en). This feature is used when the reader field has to be maintained while no response from a tag is expected. Another example is NFCIP-1 active communication in receive mode configuration. The RF field is generated by the initiator on one side while the other side is only in receive operation.

Asserting the *Operation control register* bit wu while the other bits are set to 0 puts the ST25R39xxB into the Wake-up mode that is used to perform low power detection of card presence. In this mode the low power RC oscillator and register configurable wake-up timer are used to schedule periodic measurement(s). When a difference to the predefined reference is detected an interrupt is sent to wake-up the MCU. Phase and amplitude measurement are available to trigger the wake-up.

4.2.1 Transmitter

The transmitter contains two identical push-pull driver blocks connected to pins RFO1 and RFO2. These drivers are differentially driving the external antenna LC tank. It is also possible to operate only one of the two drivers by setting the *IO configuration register 1* bit single and selecting which RFO/RFI to be use on bit rfo2.

Output resistance

Each driver is composed of eight segments having binary weighted output resistance. The MSB segment typical ON resistance is 4 Ω . When all segments are turned on, the output resistance is typically 2 Ω . Usually all segments are turned on to define the normal transmission (non-modulated) level. It is also possible to switch off certain MSB segments when driving the non-modulated level to drive the circuitry with a higher impedance driver.

The bits d_res<3:0> in the *TX driver register* define the resistance during the normal transmission. The default setting is minimum available resistance.

When using the single driver mode, the number and therefore the cost of the antenna LC tank components is halved, but also the output power is reduced. In single mode it is possible to connect two antenna LC tanks to the two RFO outputs and multiplex between them by controlling the *IO configuration register 1* bit rfo2.

To transmit data, the transmitter output level needs to be modulated. AM and OOK modulation principles are supported. The type of modulation is defined by setting bit tr_am in the *Mode definition register*.

Driver TX modulation

During the OOK modulation (e.g. for ISO14443A) the transmitter drivers stop driving the carrier frequency. As a consequence the amplitude of the antenna LC tank oscillation decays, the time constant of the decay is defined with the LC tank Q factor.

AM modulation (for example ISO14443B) is done via an additional regulator providing the supply voltage V_{DD_AM} , used as the driver supply voltage during the modulation state.

The AM modulation level is set by am_mod3:0 bits in the *TX driver register*.

AM modulation has to be manually enabled and the level to be set correctly for the following protocols:

- ISO14443B
- FeliCa
- ISO15693 (if not OOK)
- NFCIP-1 212 and 424 kb/s initiator or active target.

Depending on the applicable standard the modulation index is set in a range between 0 and 82% in the *TX driver register*.

Passive load modulation

The ST25R3916B enables passive load modulation using two different methods

- Internal driver load modulation
- Load modulation with an external MOS transistor and a diode that directly loads the antenna circuit

The driver load modulation is selected by bit `lm_dri` and the external MOS modulation is selected by `lm_ext` option bits.

Normally, the internal driver or the external load modulation should be used exclusively, but the device also allows simultaneous modulation.

The driver load modulation is based on the change of driver impedance. Typically, a high impedance during non-modulated state and a lower impedance for the modulated state is used. This yields modulation phase equal to passive tag modulation. It is also possible to reverse the polarity of the driver load modulation by using low impedance during non-modulated state and higher impedance for the modulated state.

During the non-modulated state the output impedance is defined by `pt_res3:0` option bits. During modulation the output impedance is defined by `ptm_res3:0` option bits.

Load modulation through an external MOS transistor and a diode is selected by the `lm_ext` option bit. In this case the `EXT_LM` pin is driven by the digital representation of the load modulation signal (848 kHz subcarrier or 424 / 212 kHz modulation signal). The `EXT_LM` is used to drive a gate of the external modulation MOS. The bit `lm_ext_pol` sets inverse polarity for the external load modulation.

The `pt_res3:0` and `ptm_res3:0` bits must be set prior entering passive target mode (reg 03h), because in passive target mode the resistance value propagates through the TX driver only when the extracted clock is available.

Driver load modulation is based on change of the driver impedance. Typically high impedance is used during non-modulated state, and decreased for modulated state, resulting in modulation phase equal to Passive tag modulation.

It is also possible to set inverse polarity driver load modulation by using low impedance during non-modulated state and higher impedance for the modulated state.

During non-modulated / modulated state the output impedance is defined, respectively, by `pt_res3:0` / `ptm_res3:0` option bits.

An external MOS transistor and a diode modulation is selected by `lm_ext` option bit. In this case the `EXT_LM` pin is driven by digital representation of the load modulation signal (848 kHz subcarrier or 424 / 212 kHz modulation signal). The `EXT_LM` is used to drive a gate of the external modulation MOS.

Bit `lm_ext_pol` sets inverse polarity for the External load modulation.

Bits `pt_res<3:0>` and `ptm_res<3:0>` must be set before entering Passive target mode (reg 03h), as in Passive target mode the resistance value propagates through the TX driver only when extracted clock is available (during PT data transmission, including FDT).

4.2.2 Receiver

The receiver performs demodulation of the tag subcarrier modulation that is superimposed on the 13.56 MHz carrier frequency. It performs AM/PM or I/Q demodulation, amplification, band-pass filtering and digitalization of subcarrier signals. It also performs RSSI measurement, automatic gain control (AGC) and Squelch function.

The reception chain has two separate channels for AM and PM demodulation. When both channels are active the selection for reception framing is done automatically by the receiver logic. The receiver is switched on when *Operation control register* bit `rx_en` is set to 1.

The *Operation control register* contains bits rx_chn and rx_man, which define whether only one or both demodulation channels are active:

- bit rx_man defines the channel selection mode when both channels are active (automatic or manual)
- bit ch_sel defines which channel is used for decoding.

Table 4. RX channel selection

rx_chn	rx_man	ch_sel	Selected reception channel
0	0	x	Automatic selection
0	1	0	AM or I channel
0	1	1	PM or Q channel
1	x	0	AM or I channel
1	x	1	PM or Q channel

Figure 7. Receiver block diagram

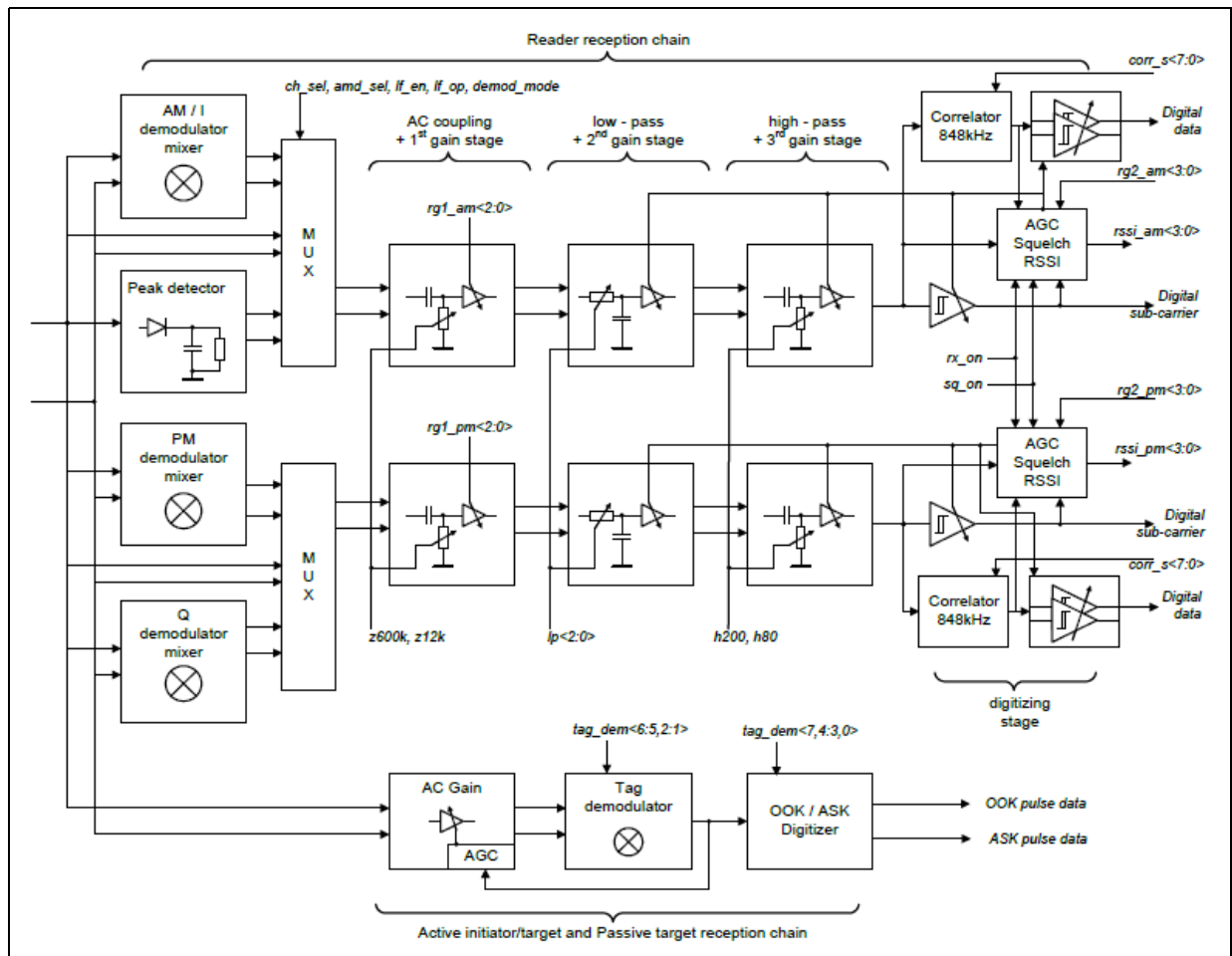

Demodulation stage

The first stage performs demodulation of the tag subcarrier response signal, superimposed on the HF field carrier. Two different blocks are implemented for the AM demodulation:

- peak detector
- AM/I or PM/Q demodulator mixer.

The choice of the used demodulator is made by the [Receiver configuration register 2](#) bit amd_sel.

The peak detector performs AM demodulation using a peak follower. Both the positive and negative peaks are tracked to suppress any common mode signals. Its demodulation gain is $G = 0.7$ and the input is taken from RF11 demodulator input only.

The AM demodulator mixer uses synchronous rectification of both receiver inputs (RF11 and RF12). Its gain is $G = 0.55$. The PM demodulation is also done by a mixer. The PM demodulator mixer has differential outputs with 60 mV differential signal for 1% phase change ($16.67 \text{ mV} / ^\circ$).

The I/Q demodulation is composed of two mixer circuits, driven with a 90° shifted local oscillator (LO) signals derived from the crystal oscillator. The outputs of the two mixers are connected to two equal base band reception chains and to the decoding logic.

Filtering and gain stages

The receiver chain has band pass filtering characteristics. The filtering is optimized to pass subcarrier frequencies while rejecting carrier frequency, low frequency noise and DC component. Filtering and gain is implemented in three stages, the first and the last stage have first order high pass characteristics while the mid stage has second order low-pass characteristic.

The gain and filtering characteristics can be optimized depending on the application by writing the [Receiver configuration register 1](#) (filtering), [Receiver configuration register 3](#) (primarily gain in first stage) and [Receiver configuration register 4](#) (gain in second and third stage).

The gain of first stage is around 20 dB and can be reduced in six 2.5 dB steps. There is also a special boost mode available, which increases the max gain by additional 5.5 dB. The first stage gain can only be modified by writing [Receiver configuration register 3](#). The default setting of this register is the minimum gain. Default first stage zero is located at 60 kHz, it can also be lowered to 40 or 12 kHz by writing option bits in the [Receiver configuration register 1](#). The first stage can be reconfigured to second order high-pass at 600 kHz by option bit z600k. The control of the first and third stage zeros is done with common control bits (see [Table 6](#)).

Table 5. Low-pass control

rec1<5>lp2	rec1<4>lp1	rec1<3>lp0	-1 dB point
0	0	0	1200 kHz
0	0	1	600 kHz
0	1	0	300 kHz
1	0	0	2 MHz

Table 5. Low-pass control (continued)

rec1<5>lp2	rec1<4>lp1	rec1<3>lp0	-1 dB point
1	0	1	7 MHz
Others			Not used

Table 6. First and third zero setting

rec1<3>z600k	rec1<2>h200	rec1<1>h80	rec1<0>z12k	First stage zero	Third stage zero
0	0	0	0	60 kHz	400 kHz
0	1	0	0		200 kHz
0	0	1	0	40 kHz	80 kHz
0	0	0	1	12 kHz	200 kHz
0	0	1	1		80 kHz
0	1	0	1		200 kHz
1	0	0	0	600 kHz	400 kHz
1	1	0	0		200 kHz
Others				Not used	

The gain in the second and third stage is 23 dB and can be reduced in six 3 dB steps. Gain of these two stages is included in AGC and Squelch loops or can be manually set in [Receiver configuration register 4](#). Sending of direct command Reset RX Gain is necessary to initialize the AGC, Squelch and RSSI block. Sending this command clears the current Squelch setting and loads the manual gain reduction from [Receiver configuration register 4](#). Second stage has a second order low-pass filtering characteristic, the pass band is adjusted according to subcarrier frequency using the bits lp2 to lp0 of the [Receiver configuration register 1](#). See [Table 5](#) for -1 dB cut-off frequency for different settings.

Digitizing stage

The digitizing stage produces a digital representation of the sub-carrier signal coming from the receiver. This digital signal is then processed by the receiver framing logic. The digitizing stage consists of a window comparator with adjustable digitizing window (five possible settings, 3 dB steps, adjustment range from ±33 to ±120 mV). The adjustment of the digitizing window is included in the AGC and Squelch loops. The digitizing window can also be set manually in the [Receiver configuration register 4](#).

AGC, Squelch and RSSI

As mentioned above, the second and third gain stage gain and the digitizing stage window are included in the AGC and Squelch loops. Eleven settings are available. The default state features minimum digitizer window and maximum gain. The first four steps increase the digitizer window in 3 dB steps, the next six steps reduce the gain in the second and third gain stage, again in 3 dB steps. The initial start setting for Squelch and AGC is defined in [Receiver configuration register 4](#). The [Gain reduction state register](#) displays the actual state of gain resulting from Squelch, AGC and initial settings in [Receiver configuration register 4](#).

Squelch

This feature is designed for operation in noisy environments. The noise may be misinterpreted as the start of tag response, resulting in decoding errors.

Automatic squelch is enabled by option bit `sqm_dyn` in the [Receiver configuration register 2](#). It is activated automatically 18.88 μ s after end of TX and is terminated at the moment the Mask receive timer (MRT) reaches the value defined in the [Squelch timer register](#). This mode is primarily intended to suppress noise generated by tag processing during the time when the tag response is not expected (covered by MRT).

Squelch can operate in two modes, namely with ratios 1 and 6, selectable by `pulz_61` bit in the [Receiver configuration register 2](#).

Squelch ratio 1 means that system observes the subcarrier signal from the main digitizer and decrease the system gain to decrease the frequency of transitions. If there are more than two transitions on this output in a 50 μ s time period, gain is reduced by 3 dB and output is observed during the following 50 μ s. This procedure is repeated until number of transitions in 50 μ s is lower or equal to 2 or until the maximum gain reduction is reached. This mode is intended for protocols where digitized subcarrier outputs are used.

Squelch ratio 6 means the system similarly observes and decreases the frequency seen at the window comparator set to 6 times the digitizing window. This mode is intended for protocols where output from correlators are used (ISO-A, ISO-B correlated reception).

The gain setting acquired by squelch is cleared by sending direct command [Reset RX gain](#).

AGC

The AGC (automatic gain control) reduces the gain to keep the receiver chain and input to the digitizing stage out of saturation. The demodulation process is also less influenced by system noise when the gain is properly adjusted.

The AGC logic starts operating when the signal `rx_on` is asserted to high and is reset when it is reset to low. The state of the receiver gain is stored in the [Gain reduction state register](#) during a high to low transition of bit `rx_on`. Reading this register later on gives information of the gain setting used during the last reception.

The AGC system comprises a window comparator and an AGC ratio that can be set to 3 or to 6. As an example, when the AGC ratio is set to 6 the window is six times larger than the data digitalization window comparator. When the AGC function is enabled the gain is reduced until there are no transitions on its output. Such procedure assures that the input to digitalization window comparator is up to 6 times larger than its window.

If the AGC ratio is set to three, the input to the digitalization window comparator is set to be up to 3 times larger than its window.

The AGC operation is controlled by the control bits `agc_en`, `agc_m`, `agc_alg`, and `agc6_3` in [Receiver configuration register 2](#).

The bit `agc_m` defines the AGC mode when two AGC modes are available. The AGC can operate during the complete RX process as long as the signal `rx_on` is high and it can be enabled only during first eight subcarrier pulses.

There are two AGC algorithms to choose from bit `agc_alg`. The AGC can start either by pre-setting (maximum digitizer window and maximum gain) or by resetting (minimum digitizer window and maximum gain) it. The algorithm with preset is faster and therefore recommended for protocols with short SOF (like ISO14443A at 106 kbps).

Correlator

The correlators correlate the incoming filtered subcarrier with 848 kHz. The aim of the correlation is to maximize the system sensitivity at 848 kHz, while rejecting other frequencies. There are two correlators in the system for AM (or I) channel and PM (or Q) channel.

Correlator settings are defined in [Correlator configuration register 1](#) and [Correlator configuration register 2](#).

RSSI

The receiver also performs the RSSI (received signal strength indicator) measurement for both channels. The RSSI measurement is started after the rising edge of rx_on. It stays active while the signal rx_on is high and frozen while rx_on is low. It is a peak hold system where the value can only increase from initial 0 value. Every time the AGC reduces the gain the RSSI measurement is reset and starts from 0. The result of RSSI measurements is a 4-bit value that can be observed by reading the [RSSI display register](#). The LSB step is 2.8 dB, the maximum value is Dh (13d).

Since the RSSI measurement is of peak hold type, the result does not follow any variations in the signal strength (the highest value will be kept). To follow RSSI variation it is possible to reset RSSI bits and restart the measurement by sending direct command [Clear RSSI](#).

Clock extractor

The clock extractor observes the RF11 and RF12 differential signal and provides a clock signal synchronous with the incoming RF field. The extracted clock is used for synchronous demodulation, for correct frame delay time and for correct data timing during passive transmission. The clock extractor is active down to 60 mV_{PP} input signal.

4.2.3 Antenna tuning

The ST25R3916B supports antenna tuning through external variable capacitors. The variable capacitor is connected on its position in the matching network, and the tuning control voltage is connected to one of the control output pins (AAT_A, AAT_B).

The variable capacitors can be connected in series and parallel configurations in the matching network. Further information on the various configuration options can be found in the application note AN5322, available on www.st.com.

The phase and amplitude detector block is used for resonance frequency checking. The algorithm in the MCU evaluates the result and adjusts the tuning voltages at AAT_A and AAT_B output pins via the [Antenna tuning control register 1](#) and [Antenna tuning control register 2](#) according to the procedure in the MCU firmware.

The AAT_A/B pin voltages are actively set according to [Antenna tuning control register 1](#) and [Antenna tuning control register 2](#) when en and aat_en option bits are both set.

If aat_en=1 and en=0, the AAT_A/B voltages are set to a fixed value between 1.5 and 2.2 V (typically 1.9 V).

4.2.4 Wake-up mode

Asserting the *Operation control register* bit *wu* while the other bits are set to 0 puts the ST25R39xxB into the Wake-up mode, used to perform low power detection of card presence. The devices feature two possibilities, namely phase and amplitude measurement. An integrated low power 32 kHz RC oscillator and register configurable Wake-up timer are used to schedule periodic detection.

Usually the presence of a card is detected by a so-called polling. In this process the reader field is periodically turned on and the controller checks whether a card is present using RF commands. This procedure consumes a lot of energy since reader field has to be turned on for 5 ms before a command can be issued.

Low power detection of card presence is performed by detecting a change in the reader environment, produced by a card. When a change is detected, an interrupt is sent to the controller. As a result, the controller performs a regular polling loop.

In Wake-up mode the ST25R39xxB periodically perform the configured reader environment measurements and sends an IRQ to the controller when a difference to the configured reference value is detected.

Card detection

The presence of a card close to the reader antenna coil produces a change of the antenna LC tank signal phase and amplitude. The reader field activation time needed to perform the phase or the amplitude measurement is extremely short (~20 μ s) compared to the activation time needed to send a protocol activation command.

The power level during the measurement can be lower than that during normal operation as the card does not have to be powered to produce a coupling effect. The emitted power can be reduced by changing the RFO driver resistance.

Registers from 32h to 3Bh are dedicated to Wake-up configuration and display. The *Wake-up timer control register* is the main Wake-up mode configuration register. The timeout period between the successive detections and the measurements which are going to be used are selected in this register. Timeouts in the range from 10 to 800 ms are available, 100 ms being the default value.

Registers from 33h to 3ADh configure the two possible detection measurements and store the results, four registers are used for each method.

An IRQ is sent when the difference between a measured value and reference value is larger than configured threshold value. There are two possibilities how to define the reference value:

- the ST25R39xxB can calculate the reference based on previous measurements (auto-averaging)
- the controller determines the reference and stores it in a register.

For example, the first register in the series of four is the *Amplitude measurement configuration register*. The difference to reference which triggers the IRQ, the method of reference value definition and the weight of last measurement result in case of auto-averaging are defined in this register. The next register is storing the reference value in case the reference is defined by the controller. The following two registers are display registers. The first one stores the auto-averaging reference, the second one stores the result of the last measurement.

Wake-up mode configuration registers have to be configured before Wake-up mode is actually entered. Any modification of Wake-up mode configuration while it is active may result in unpredictable behavior.

Auto-averaging and initialization of reference value

When the device is set into WU mode with auto-averaging enabled and the WU timer expires the first time, a new initial reference value is measured and stored without calculation in the corresponding register, for example, in the amplitude measurement display and auto averaging display register. The initialization of these reference values are performed each time wu bit is written from 0 to 1 in auto-averaging mode. Therefore, a WU interrupt can only occur after the second expiration of the WU timer. During the WU period, a new reference value is recalculated after every measurement and stored in the Auto Averaging Display register.

The last measurement value, the old reference value and the weight are used in this calculation. The following formula is used to calculate the new reference value:

$$\text{new_reference} = \text{old_reference} - (\text{old_reference} - \text{measured_value}) / \text{weight}$$

The calculation is done on 10 bits to have sufficient precision.

Every measurement configuration register contains a bit defining whether the measurement that causes an interrupt is taken in account for the average value calculation (for example bit am_aam of [Amplitude measurement reference register](#)).

4.2.5 Quartz crystal oscillator

The quartz crystal oscillator operates with 27.12 MHz crystals; its operation is enabled when the [Operation control register](#) bit en is set to 1. An interrupt is sent to inform the microcontroller when the oscillator amplitude is sufficiently high, meaning the frequency is stable (see [Main interrupt register](#)).

The status of oscillator can be observed by checking the [Auxiliary display register](#) bit osc_ok. This bit is set to 1 when oscillator frequency is stable.

The oscillator is based on an inverter stage supplied by a controlled current source. A feedback loop is controlling the bias current in order to regulate amplitude on XTI pin to $1 V_{PP}$. To enable a fast reader start-up an interrupt is sent when oscillator amplitude exceeds $750 mV_{PP}$.

Division by two assures that 13.56 MHz signal has a duty cycle of 50%, which is better for the transmitter performance (no PW distortion).

The oscillator output is also used to drive a clock signal output pin MCU_CLK, which can be used by the external microcontroller. The MCU_CLK pin is configured in the [IO configuration register 2](#).

4.2.6 Timers

The ST25R39xxB contain several timers, which eliminate the need to run counters in the controller, thus reducing the effort of the controller code implementation and improve portability of code to different controllers.

Every timer has one or more associated configuration registers in which the timeout duration and different operating modes are defined. These configuration registers have to

be set while the corresponding timer is not running. Any modification of timer configuration while the timer is active may result in unpredictable behavior.

All timers are stopped by the direct command *Stop all activities*.

Mask receive timer (MRT)

In Reader mode this timer is blocking the receiver and reception process in framing logic by keeping the rx_on signal low after the end of TX during the time the tag reply is not expected. While Mask Receive timer is running the Squelch is automatically turned on when enabled. The MRT does not produce an IRQ.

The MRT timeout is configured in the *Mask receive timer register* and is automatically started at the end of data transmission (at the end of EOF).

The MRT can be triggered by direct command Start Mask-receive timer. In this case the squelch is enabled, according to the *Squelch timer register*.

In the NFCIP-1 Active Initiator, Active and Passive Target communication modes the MRT is started when the other device turns on its field and the external field detector signals l_eon.

MRT supports a longer timing needed for NFCIP1 by setting option bit mrt_step. The bit switches between fc/64 and fc/512 step size.

The MRT starts also in the low power Initial NFC target mode. After the initiator field has been detected the controller turns on the 27 kHz RC oscillator, regulator, crystal oscillator, receiver and MRT. After the MRT expires the receiver output starts to be observed to detect start of the initiator message.

For correct operation in the low power Initial NFC target mode the mrt_step = 1 must be used. The 27 kHz RC oscillator is used as a MRT clock source for the time before the crystal oscillator stabilises. This enables that the actual MRT time is a good approximation to the targeted time, also in case the crystal oscillator is not running yet.

No-response timer (NRT)

The purpose of this timer is intended to observe whether a response is detected during a configured time started by end of transmission. The l_nre flag in the *Timer and NFC interrupt register* is signaling interrupt events resulting from this timer timeout.

The NRT is configured by writing *No-response timer register 1* and *No-response timer register 2*). Operation options are defined by setting bits nrt_emv and nrt_step in the *Timer and EMV control register*.

The NRT is automatically started at the end of transmission.

Bit nrt_step configures the time step of the No-response timer. Two steps are available, 64/fc (4.72 μs) and 4096/fc, covering, respectively, the range up to 309 ms and up to 19.8 s.

Bit nrt_emv controls the timer operation mode.

- When this bit is set to 0 (default mode) the IRQ is produced if the NRT expires before a start of a response is detected. The rx_on is set low to disable the receiver. In the opposite case, when the start of a tag reply is detected before timeout, the timer is stopped, and no IRQ is produced.
- When this bit is set to 1 the timer unconditionally produces an IRQ when it expires, it is also not stopped by direct command Stop all activities. This means that the IRQ is independent from whether or not a tag reply was detected. When a tag reply is being processed during a timeout, no other action is taken and the reply is normally received.

In the opposite case, when no tag response is being processed, the receiver is disabled.

The NRT can also be started using direct command Start No-response timer. The intention of this command is to extend the No-response timer timeout beyond the range defined in the No-response timer control registers. If this command is sent while the timer is running, it is reset and restarted.

The NRT can be terminated using direct command Stop No-response Timer or [Stop all activities](#). The timer is terminated and no IRQ is sent. It is expected to be used in the nrt_emv mode, when the incoming reception does not stop the No-response timer.

In the NFCIP-1 active communication mode the NRT role is similar to operation in the normal Reader mode. If the NRT expires before the start of a response is detected an IRQ is produced and the receiver is disabled. There are two modes available:

- nrt_nfc = 0
 - The timer is started when the device TX field is switched off, using a general purpose timer.
 - The operation is valid for active initiator and target modes as well as for bit rate detection mode.
- nrt_nfc = 1
 - The timer is started when the peer field is turned on.
 - Operation is valid for Active initiator and Active target modes.

For Bit rate detection mode the timer is not started at peer field on as, in case of migration from Bit rate detection mode to Active target mode, the MCU has to reconfigure the device to Active target mode prior field on.

In the NFCIP-1 Passive target the No-response timer has no task and is not automatically started.

PPON2 timer

This timer is not used in Reader mode.

In NFCIP-1 mode this timer is automatically started when the transmitter is turned off after the message has been sent. If this timer expires before the peer NFC device ($T_{FADT} + n \cdot T_{RFW}$) field-on is detected, an I_ppon2 IRQ is sent. I_txe is must be read before the I_gpe for PPON2 timer to be started.

If the external RF field is detected on time, the timer is stopped and no IRQ is sent.

Time is defined in the [PPON2 field waiting register](#).

General purpose (GP) timer

The triggering of the this timer is configured by setting the [Timer and EMV control register](#). It can be used to survey the duration of reception process (triggering by start of reception, after SOF) or to time out the PCD to PICC response time (triggered by end of reception, after EOF).

In the NFCIP-1 active communication mode it is used to timeout the field switching off. In all cases an IRQ is sent when it expires.

The GP timer can also be started by sending the direct command Start General purpose timer. If this command is sent while the timer is running, it is reset and restarted.

Wake-up (WU) timer

This timer is primarily used in the Wake-up mode, it can be used by sending the direct command Start Wake-up Timer. This command is accepted in any operation mode except Wake-up mode. When this command is sent the RC oscillator, which is used as clock source for wake-up timer is started, timeout is defined by setting the [Wake-up timer control register](#). When the timer expires, an IRQ with the I_wt flag in the [Error and wake-up interrupt register](#) is sent.

The WU timer is used in the Power-down mode, in which other timers cannot be used because the crystal oscillator, which is the clock source for the other timers, is not running. Note that the tolerance of wake-up timer timeout is defined by tolerance of the RC oscillator.

In NFCIP-1 passive target mode the WU timer is used for time out the temporary device enable after the initial peer field on was detected.

4.2.7 A/D converter

The ST25R39xxB contain an 8-bit successive approximation A/D converter. Inputs can be multiplexed from different sources to be used in several direct commands and adjustment procedures. The result of the last conversion is stored in the [A/D converter output register](#). Typical conversion time is $224/f_c$ (16.5 μ s).

The A/D converter has two operating modes, absolute and relative.

- In absolute mode the low reference is 0 V and the high reference is 2 V. This means that A/D converter input range is from 0 to 2V, 00h code means input is 0 V or lower, FFh means that input is 2 V - 1 LSB or higher, LSB being 7.8125 mV.
- In relative mode low reference is 1/11 of V_{DD_A} and high reference is 10/11 of V_{DD_A} , so the input range is from $1/11 V_{DD_A}$ to $10/11 V_{DD_A}$.

Relative mode is only used in phase measurement (phase detector output is proportional to power supply). In all other cases absolute mode is used.

4.2.8 Phase and amplitude detector

This block is used to provide inputs to the A/D converter to perform measurements of amplitude and phase, expected by direct commands [Measure amplitude](#) and [Measure phase](#).

Phase detector

The phase detector observes phase difference between the transmitter output signals (RFO1 and RFO2) and the receiver input signals RFI1 and RFI2, proportional to the signal on the antenna LC tank. These signals are first passed by digitizing comparators. Digitized signals are processed by a phase detector with a strong low-pass filter characteristics to get the average phase difference. The phase detector output is inversely proportional to the phase difference between the two inputs. The 90° phase shift results in $V_{DD_A}/2$ output voltage, if both inputs are in phase the output voltage is V_{DD_A} , if they are in opposite phase the output voltage is 0 V. During execution of direct command [Measure phase](#) this output is multiplexed to the A/D converter input (A/D converter is in relative mode during the execution of this command). Since the A/D converter range is from $1/11 V_{DD_A}$ to $10/11 V_{DD_A}$ the actual phase detector range is from 17° to 163°. [Figure 8](#) and [Figure 9](#) show the two inputs and output of phase detector in case of 90° and 135° phase shift, respectively.

Figure 8. Phase detector inputs and output in case of 90° phase shift

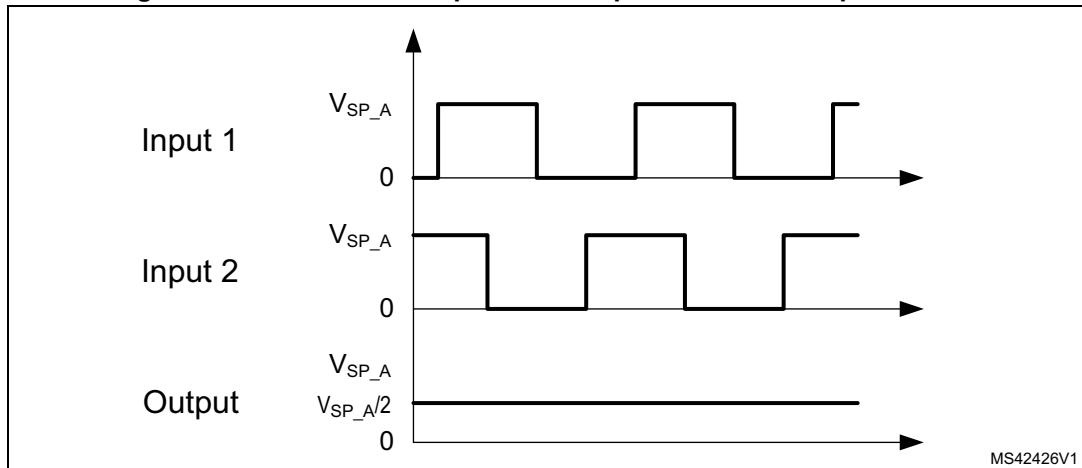
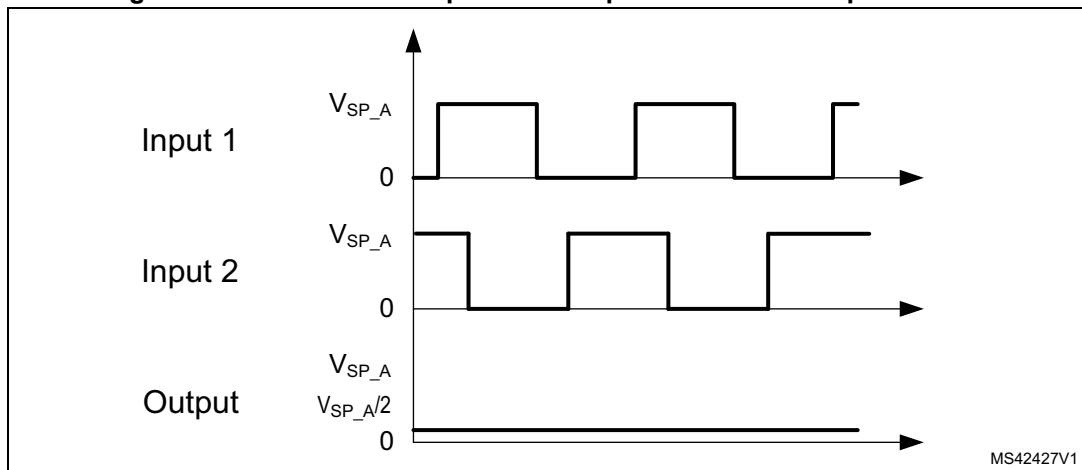

Figure 9. Phase detector inputs and output in case of 135° phase shift



Amplitude detector

Signals from pins RF11 and RF12 are used as inputs to the self-mixing stage. The output of this stage is a DC voltage proportional to the amplitude of signals on pins RF11 and RF12. During execution of direct command *Measure amplitude* this output is multiplexed to the A/D converter input.

4.2.9 External field detector

This block is used to detect the presence of an external device generating an RF field. It is used in NFCIP-1 Active communication and Passive target modes. It is enabled by `en_fd_c<1:0>` option bits. The external field detector supports two different detection thresholds, namely Peer detection and Collision avoidance. The two thresholds can be independently set by writing the *External field detector activation threshold register*. The actual state of the detector output can be checked by reading the *Auxiliary display register*. Input to this block is the signal from the RF11 pin.

For both thresholds there is a possibility to separately set the activation and deactivation levels.

If the External field level is not detected yet, the Activation threshold is used. If the External field level is detected, the Deactivation threshold is used.

The Activation threshold must be set higher than or equal to the Deactivation threshold.

If the Activation is higher than the Deactivation, the hysteresis is given by the difference between the two levels.

If the Activation and Deactivation levels are equal, there is no the hysteresis in the system and multiple field-on/off events can verify if the actual field level persists in proximity of the selected threshold.

Peer detection threshold

This threshold is used to detect the field emitted by peer NFC device with whom NFC communication is going on. It can be selected in the range from 75 to 800 mV_{PP}. When this threshold is enabled the detector is in low-power mode. An interrupt is generated when an external field is detected and also when it is switched off. With such implementation it can also be used to detect the moment when the external field disappears. This can be used to detect the moment when the peer NFC device (either an initiator or a target) has stopped emitting an RF field.

The External Field Detector is enabled in low power Peer Detection mode by setting bits `en_fd_c,1:0` in the [Operation control register](#).

Collision avoidance threshold

This threshold is used during the RF collision avoidance sequence, which is executed by sending NFC Field ON commands (see [Section 4.4.5: NFC field ON commands](#)). It can be selected in the range from 25 to 800 mV_{PP}.

4.2.10 Power supply system

The ST25R39xxB feature three positive supply pins, VDD, VDD_TX and VDD_IO:

- VDD is the main power supply pin. It supplies the ST25R39xxB blocks through two regulators (V_{DD_A}, V_{DD_D})
- VDD_TX is the transmitter supply pin. It supplies the transmitter via two regulators (V_{DD_RF}, V_{DD_AM}). V_{DD} range from 2.4 to 5.5 V is supported. VDD and VDD_TX must be connected to the same power supply.
- V_{DD_IO} is used to define supply level for digital communication pins (BSS, MISO, MOŠI, SCLK, IRQ, MCU_CLK). Digital communication pins interface to the ST25R39xxB logic through level shifters, therefore the internal supply voltage can be either higher or lower than V_{DD_IO}. V_{DD_IO} range from 1.65 to 5.5 V is supported.

[Figure 10](#) details the building blocks of the ST25R39xxB power supply system. It contains three regulators, a power-down support block, a block generating analogue reference voltage (AGDC) and a block performing automatic power supply adjustment procedure. The three regulators are providing supply to analogue blocks (V_{DD_A}), logic (V_{DD_D}) and transmitter (V_{DD_RF}). The use of V_{DD_A} and V_{DD_D} regulators is mandatory at 5 V power supply to provide regulated voltage to analogue and logic blocks, which only use 3.3 V. The use of V_{DD_A} and V_{DD_D} regulators at 3 V supply and V_{DD_RF} regulator at any supply voltage is recommended to improve system PSRR.

Regulated voltage can be adjusted automatically to have maximum possible regulated voltage while still having good PSRR. All regulator pins also have corresponding negative supply pins externally connected to ground potential (V_{SS}). [Figure 1](#) and [Figure 2](#) show

actual regulated voltage, which is result of direct command [Adjust regulators](#), can be observed.

The V_{DD_RF} regulator includes a current limiter that limits the regulator current to 350 mA_{rms} in normal operation. The i_{lim} in the [Regulator display register](#) is set when the V_{DD_RF} regulator is in current limiting mode.

If a transmitter output current higher than 350 mA_{rms} is required the V_{DD_RF} regulator cannot be used to supply the transmitter. V_{DD_RF} and V_{DD_DR} have to be externally connected to V_{DD_TX} (connection of V_{DD_RF} to supply voltage higher than V_{DD_TX} is not allowed).

The voltage drop of the transmitter current is the main source of the ST25R39xxB power dissipation. This voltage drop is composed of a drop in the transmitter driver and of a drop in the V_{DD_RF} regulator. Due to this it is recommended to set the regulated voltage using direct command [Adjust Regulators](#). It results in good power supply rejection ratio with relatively low dissipated power due to regulator voltage drop.

In Power-down mode the V_{DD_RF} regulator is not operating. V_{DD_RF} pin is connected to V_{DD_TX} through a 1 k Ω resistor. Connection through resistors assures smooth power-up of the system and a smooth transition from Power-down mode to other operating modes.

V_{DD_AM} regulator

This regulator is used to support the transmitter AM modulation. Its output voltage is used as transmitter supply during modulation phase. The output is internally connected to the transmitter. It requires decoupling capacitors (2.2 μ F_{NOM} for Regulator AM and 22nF_{NOM} for AWS AM) at V_{DD_AM} pin. Additionally, 100pF to 2.2nF can be used to improve RF decoupling.

V_{DD_DR} is used as reference voltage, resulting in correct V_{DD_AM} voltage and modulation index at supply voltage between 2.4 and 5.5 V.

The output voltage and thus modulation setting is controlled by `am_mod<3:0>` option bits from 0 to 82% in 16 steps.

In Power-down mode the V_{DD_AM} regulator is not operating. V_{DD_AM} pin is connected to V_{DD_TX} through 1 k Ω resistor, as in the V_{DD_RF} regulator.

V_{DD_A} and V_{DD_D} regulators

V_{DD_A} and V_{DD_D} regulators are used to supply the ST25R39xxB analog and digital blocks respectively. In 3.3 V mode V_{DD_A} and V_{DD_D} regulator are set to the same regulated voltage as the V_{DD_RF} regulator, in 5 V mode V_{DD_A} and V_{DD_D} regulated voltage is fixed to 3.4 V.

The use of V_{DD_A} and V_{DD_D} regulators is mandatory in 5 V mode since analog and digital blocks supplied with these two pins contain low voltage transistors which support maximum supply voltage of 3.6 V. In 3.3 V supply mode the use of regulators is strongly recommended to improve PSRR of analog processing.

For low cost applications it is possible to disable the V_{DD_D} regulator and to supply digital blocks through external short between V_{DD_A} and V_{DD_D} (configuration bit `vspd_off` in the [IO configuration register 2](#)).

Power-down support block

In the Power-down mode the regulators are disabled to save current. In this mode a low power Power-down support block that keeps V_{DD_D} and V_{DD_A} below 3.6 V is enabled. Typical regulated voltage in this mode is 3.1 V at 5 V supply and 2.2 V at 3 V supply. When 3.3 V supply mode is set this block is disabled, its output is connected to VDD through a 1 k Ω resistor.

Typical consumption of Power-down support block is 600 nA at 5 V supply.

Measurement of supply voltages

Using direct command [Measure power supply](#) it is possible to measure V_{DD} and regulated voltages V_{DD_A} , V_{DD_D} and V_{DD_RF} .

4.2.11 Overshoot / undershoot protection

The overshoot / undershoot protection mechanism makes it possible to control the transmitting waveform during challenging test conditions. This is accomplished by setting bit patterns in the corresponding registers that produce additional signals during the transition phase from modulated to unmodulated state or vice versa.

Note: [ST25R3916 legacy overshoot / undershoot protection mode is only valid when \$rgs_am = 0\$, for this reason, specific drive levels must be set. For the ST25R39xxB devices, the overshoot / undershoot bits can be simply activated and used in conjunction with AWS registers.](#)

The operation of this protection is explained by using the overshoot registers. The overshoot mechanism is only effective when bits are written in $ov_pattern<13:0>$. Setting $ov_pattern<13:0>$ to 0 implicitly disables the overshoot protection, as the configuration from [Mode definition register](#) and [TX driver register](#) is applied for all clock cycles after the transition.

The overshoot mode has to be set in control bits $ov_tx_mode<1:0>$ and defines the drive level for the complete bit pattern. Three modes are available.

- $ov_tx_mode<1:0> = 00b$: the transmitter outputs are driven with V_{DD_DR} when the respective $ov_pattern$ bit is 1.
- $ov_tx_mode<1:0> = 01b$: the transmitter outputs are driven with V_{DD_AM} when the respective $ov_pattern$ bit is 1.
- $ov_tx_mode<1:0> = 10b$: the transmitter outputs are stopped (like Type A pause) when the respective $ov_pattern$ bit is 1.

The overshoot protection pattern $ov_pattern<13:0>$ is applied LSB first. For the first 14 clock cycles after the transition from modulated to unmodulated state, each of the 14 bits of the overshoot protection pattern specifies the driver configuration to apply. So $ov_pattern<0>$ defines which driver configuration to apply for the first clock cycle after the transition from modulated to unmodulated state, and $ov_pattern<9>$ defines which driver configuration to apply for the tenth clock cycle after the transition from modulated to unmodulated state. From the 15th clock cycle on the settings from [TX driver register](#) are used.

The undershoot protection works in a similar manner for transitions from unmodulated state of the carrier to modulated state of the carrier.

4.2.12 Active wave shaping

To use the specific wave shaping functionality of ST25R3916B, the logic must be enabled in the auxiliary modulation setting as well as the corresponding AWS registers. Additionally, the external VDD_AM capacitor must be selected in a range of 10-50 nF.

Note: Contrary to the recommendations for the ST25R3916, do not insert a 2.2 μF capacitor on the VDD_AM pin when using AWS.

To generally enable the ST25R3916B specific AWS:

- set 0x28h in register SpaceB (Auxiliary modulation setting register) to 0x94h
- set 0x2Eh in register SpaceB (AWS configuration) to 0x08h

The following registers need to be adjusted depending on whether OOK (for instance NFC-A) or ASK (for instance NFC-B, NFC-F) modulation is transmitted.

OOK:

- set am_mod<0:3> in TX driver register to 0xFXh, which is the lowest VDD_AM level during modulation (82 % modulation index)
- clear am_sym and set en_modsink in AWS Config 2 register by writing 0x1Xh, which activates nonsymmetrical shape and strong en_modsink during OOK.

ASK:

- set am_mod<0:3> in TX driver register to the required modulation index, which could be 0x4Xh or 12% for the usual case, for instance NFC-B.
- set am_sym and clear en_modsink in AWS Config 2 register by writing 0x2Xh, which activates symmetrical shape and weak en_modsink during ASK.

The shaping of the modulation pulse is done through am_filt speed and by setting the switching time of the clamp between VDD_RF and VDD_AM.

The following picture gives a graphical representation of the wave shaping mechanism and involved register bits.

Figure 11. AWS mechanism

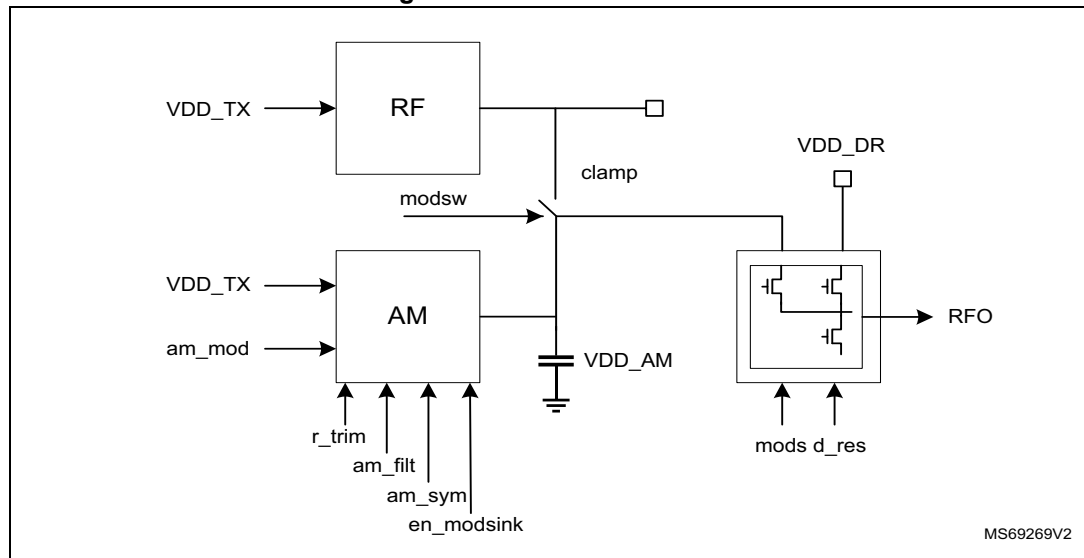

The AM regulator, together with the am_filt bits, and circuitry behind, creates the reference for the filter curve. A larger value of am_filt results in a larger time constant of the VDD_AM regulator, and a slower signal transition. All timer names in AWS register that end with "1" (for instance, tmodsw1) represent the timer starts at falling edge. Similarly, all timer names that end with '2' (for instance, tmodsw2) mean that the timer starts at rising edge (end of modulation).

The typical preset values for slow, medium and fast transients in OOK and ASK can be applied by setting as showed in the below table:

Table 7. Typical preset values for slow, medium and fast transients in OOK and ASK

Slow transient	Medium transient	Fast transient
AWS Config 2 = 0xXCh	AWS Config 2 = 0xX8h	AWS Config 2 = 0xX4h
AWS time 1 = 0x01h	AWS time 1 = 0x01h	AWS time 1 = 0x01h
AWS time 3 = 0x9Ch	AWS time 3 = 0x79h	AWS time 3 = 0x57h
AWS time 4 = 0x0Ah	AWS time 4 = 0x07h	AWS time 4 = 0x06h

Note: The settings must be adjusted individually with the final antenna.

Timing related information when using OOK

The following figure represents the interaction between bits and timings during active wave shaping in OOK modulation.

Figure 12. Bit and timing relation for OOK waveform

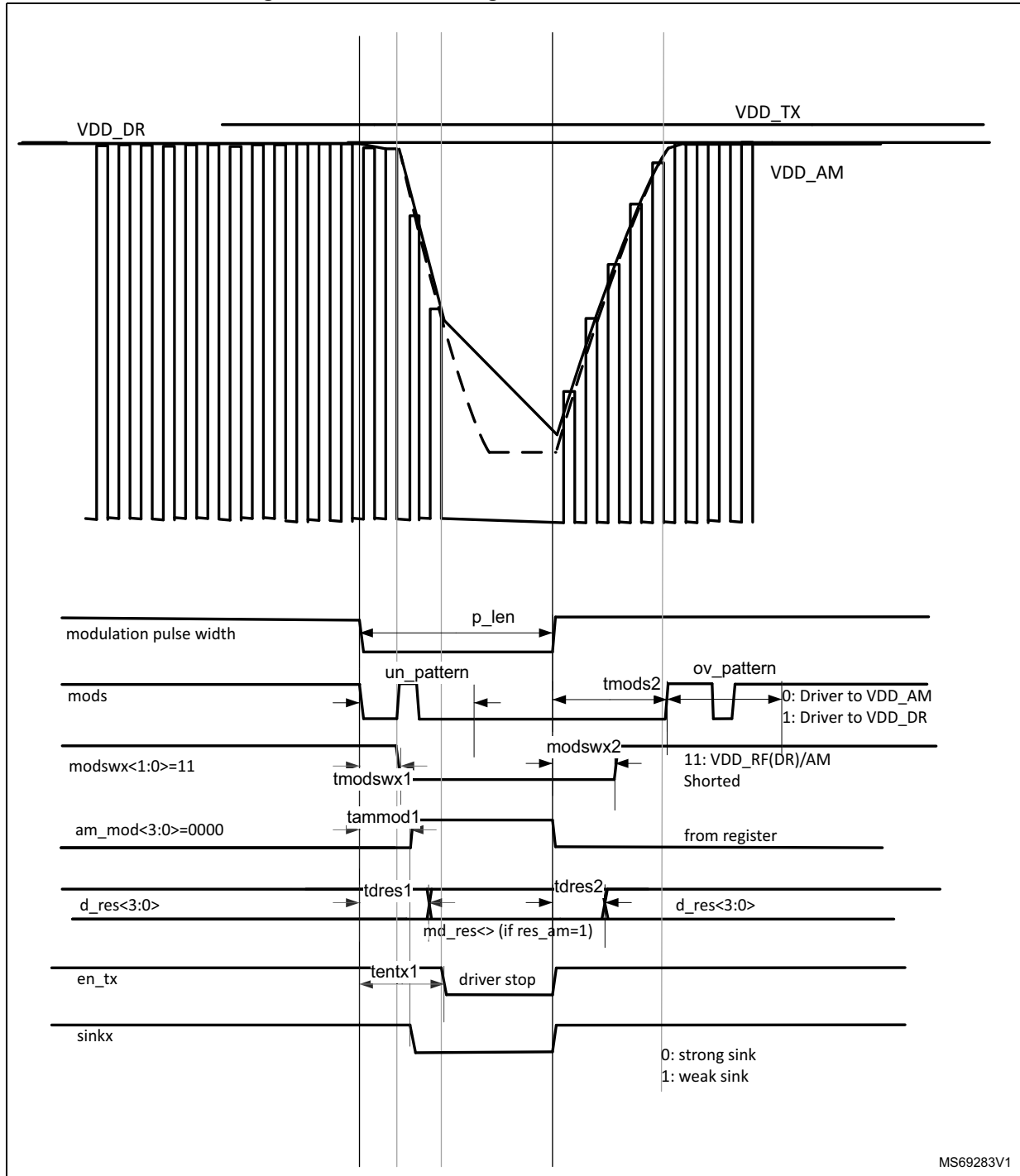

The following figure represents the interaction between bits and timings during active wave shaping in OOK modulation.

Figure 13. Bit and timing relation for ASK waveform

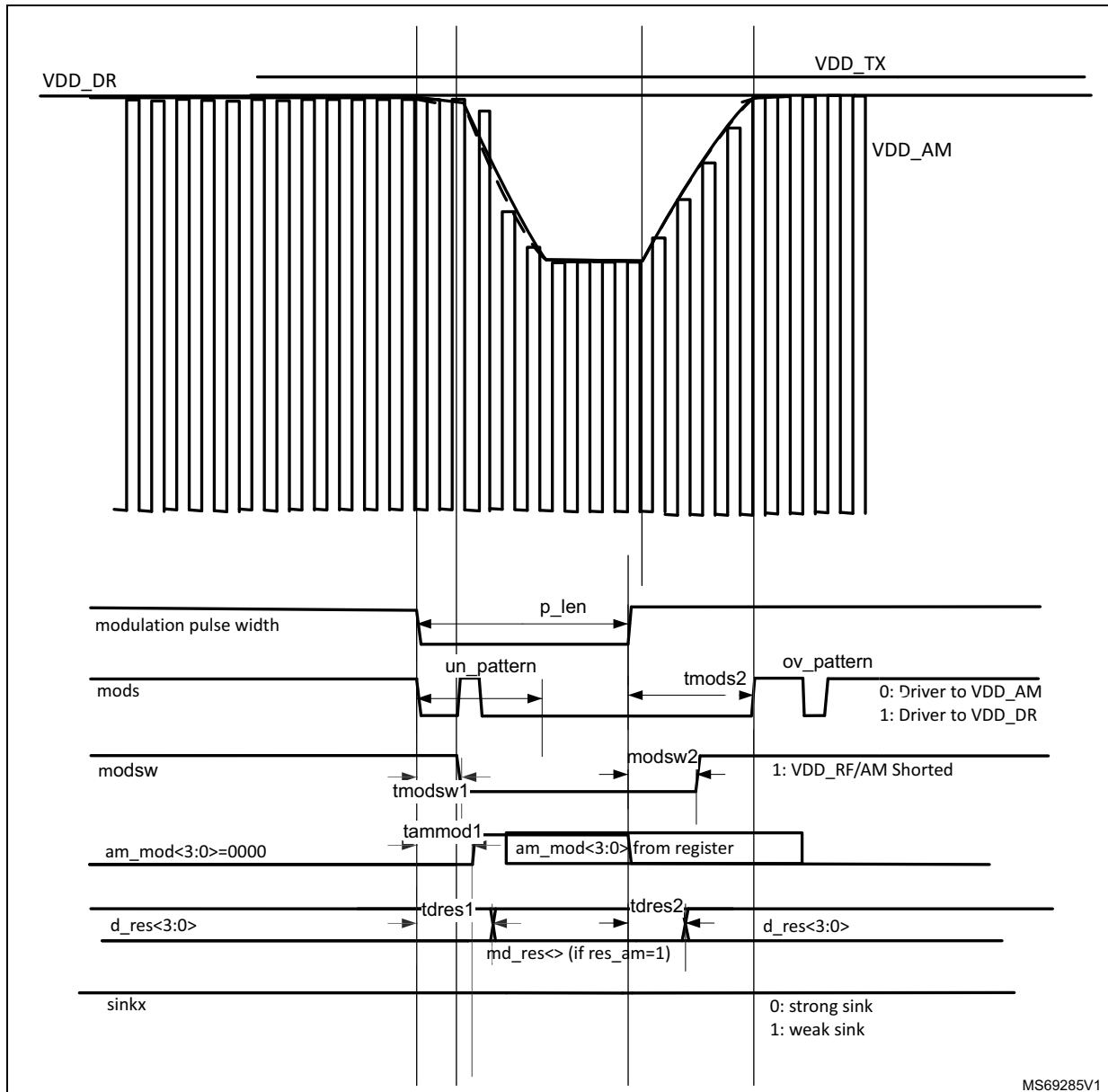

Note: The over- and undershoot patterns can be applied additionally to the AWS specific settings to further decrease over- and undershoot effects in the waveform signal.

4.2.13 Reader operation

The Ready mode has to be entered by setting the bit *en* of the *Operation control register*. In this mode the oscillator is started and the regulators are enabled. When the oscillator operation is stable an interrupt is sent and bit *osc_ok* indicates it.

The operation mode and data rate must be then configured by writing the *Mode definition register* and *Bit rate definition register*. The receiver and transmitter operation options related to operation mode have to be defined too. If the selected operation mode uses AM modulation for communication reader to tag the modulation depth must be configured.

Before sending any command to a transponder the transmitter and receiver have to be enabled by setting the bits *rx_en* and *tx_en*. Several NFC standards define a guard time (5 ms for ISO14443) requiring that the reader field must be turned on for some time before first command is sent. General purpose timer can be used to count this time or NFC Field On command with a defined time by the *NFC field on guard timer register*.

Preparation and execution of a transceive sequence:

- Execute the direct command *Stop all activities*
- Execute the direct command *Reset RX gain*
- Configure the timers accordingly
- Define the number of transmitted bytes in the *Number of transmitted bytes register 1* and *Number of transmitted bytes register 2*
- Write the bytes to be transmitted in the FIFO (not in the case of direct commands REQA and WUPA)
- Send one of the commands Transmit with CRC, Transmit without CRC, Transmit REQA or Transmit WUPA
- When all the data is transmitted an interrupt is sent to inform the microcontroller that the transmission is finished (IRQ due to end of transmission)

After the transmission is executed, the ST25R39xxB receiver automatically starts to observe the RFI inputs to detect a transponder response. The RSSI and AGC (in case it is enabled) are started. The framing block processes the subcarrier signal from receiver and fills the FIFO with data. When the reception is finished and all the data is in the FIFO an interrupt is sent to the microcontroller (IRQ due to end of receive), and the *FIFO status register 1* and *FIFO status register 1* display the number of bytes in the FIFO so the microcontroller can proceed with data download.

If an error or bit collision are detected during reception, an interrupt with appropriate flag is sent, and the microcontroller must take appropriate action.

When data packets longer than FIFO have to be transmitted the sequence detailed above changes.

The FIFO is prepared with data before the transmission starts. An interrupt is sent during the transmission to signal when the remaining number of bytes is lower than the water level (IRQ due to FIFO water level). The microcontroller then adds more data in the FIFO. When all the data are transmitted an interrupt is sent to inform the microcontroller that the transmission is finished.

The situation during reception time is similar. When the FIFO is loaded with more data than the receive water level, an interrupt is sent and the microcontroller reads the data from the FIFO. When the reception is finished an interrupt is sent to the microcontroller (IRQ due to end of receive) the *FIFO status register 1* and *FIFO status register 1* display the number of bytes in the FIFO still to be read.

4.2.14 Listen mode

The ST25R3916B listen/target mode is activated by setting to 1 bit targ in the [Mode definition register](#). There are various target or listening modes implemented depending on setting of the om<3:0> bits, refer to [Table 25: Target operation modes](#).

The main modes are

- NFCIP-1 active target
- Passive target used for Card mode and NFCIP-1 passive target

Fixed listen communication mode

Fixed communication mode is active when one of the target modes with om3=0 is selected. The other om bits control the type of communication.

Passive target

Communication can be performed by the host (through FIFO) or also by using automatic responses as referred in [NFCIP-1 passive target definition register](#).

These automatic responses include for NFC-A the complete anti-collision including SAK. Handling of RATS and HLTA is up to the host. For NFC-F only the SENSF_REQ is handled by sending SENSF_RES.

States of NFC-A can be handled by observing [Passive target display register](#) and [Passive target interrupt register](#) bits I_wu_a, I_wu_a*. Direct commands Go to sense and Go to sleep let the host influence the passive target states.

Responses to SENSF_REQ can be observed by thanks to bit I_wu_f.

The content of the automatic responses is defined by content of PT_Memory.

NFCIP-1 active target

When operating in NFCIP-1 active target mode the following settings are relevant.

- Enable external field detector by setting bit en_fd_c in the [Operation control register](#). Using the field detector allows the ST25R39xxB to turn on a response field depending on nfc_ar setting in the [Mode definition register](#). Bits nfc_n<1:0> of the [Auxiliary definition register](#) influence the timing of Response collision avoidance sequence.
- The General purpose timer defines the time until RF field off after data transmission. Its trigger source has to be set to the end of transmit, according to [Table 52: Trigger sources](#) (gptc<2:0> = 011).
- After T_ARFG either I_cat or I_cac is flagged. T_ARFG is defined by [NFC field on guard timer register](#).
- MRT starts at external field-on. NRT can be tailored by using nrt_nfc.
- After switching off its field the ST25R39xxB start the PPON2 timer and observe the External field detector output to detect the response field. If no external field is detected before PPON2 timer timeout, an IRQ with I_ppon2 flag is signaled.

Bit rate detection mode

The Listen mode can also be started from the so-called Bit rate detection mode. In this mode the communication mode is not fixed. This mode is activated in case of Target mode together with bit om3 set to 1.

The other om bits define the technologies to be recognized. It is an extension of the Fixed listen communication mode.

Once the reception of the first frame starts, the Bit rate detection mode signals an IRQ I_nfct indicating that the bit rate has been identified and the host can retrieve the related information by reading nfc_rate on [Bit rate definition register](#).

When the first frame has been fully received, the host can exit the Bit rate detection mode by setting the corresponding mode on om<3:0> bits in the [Mode definition register](#) to the corresponding fixed listen communication mode.

Bit d_ac_ap2p allows filtering of NFCIP-1 active frames.

Low power field detection

The Fixed listen communication and Bit rate detection modes can be enhanced in terms of power consumption by using the field detector in Low-power mode, putting the ST25R39xxB in power-down mode (en = 0) while waiting for an external field from a peer/reader.

For this mode the Bit rate detection mode or the Fixed listen communication mode have to be selected, and bits en, rx_en and tx_en in the [Operation control register](#) need to be cleared to 0.

In this mode the field detector has to be configured to automatic or manual peer detection threshold.

On detection of external field (I_eon) the ST25R39xxB temporarily enable the oscillator and the receiver. The host needs to confirm it by setting en and rx_en option bits in the [Operation control register](#) within 10 ms.

From this point on normal bit rate detection or normal target communication can be performed.

PT memory

The PT_Memory is used to store data for NFCIP-1 passive target and NFC-A card/listen mode. It is loaded via the host interface as described in [Section 4.3](#).

Table 8. PT_Memory address space

Location	Description	Data usage	
0-9	NFCID1 (4/7/RFU bytes)	4 bytes: locations 0-3 7 bytes: locations 0-6	NFC-A anticollision
10,11	SENS_RES2:1	SENS_REQ response	
12	SELR_L1	SEL Level 1 response.	
13	SELR_L2	SEL Level 2 response	
14	SELR_L3	RFU	
15,16	NFCF_SC	System code (SC) in SENSF_REQ ⁽¹⁾	NFC-F anticollision
17-35	212/424 polling response	SENSF_RES format ⁽²⁾	
36-47	TSN - Random numbers	Slot selection, 24 4-bit random numbers are stored ^{(3) (4)}	

1. SENSF_RES is transmitted in case received SC=NFCF_SC or SC=0xFFFF.

2. NFC-212/424k SENSF_RES format, see [Table 9](#). The last two bytes in SENSF_RES are transmitted based on the RC bytes in the SENSF_REQ.

3. The 4-bit slot numbers are sequentially used in the NFC212/424 Polling response. When only four TSN numbers remain unused, an IRQ with `1_sl_wl` bit is sent.
4. Depending on the number of slots in the Polling request, appropriate number of the MSB bits in the slot number is used.

Table 9. NFC-212/424k SENS_RES format

Byte 1	Bytes 2-9	Bytes 10-11	Bytes 12-14	Byte 15	Byte 16	Byte 17	Bytes 18-19
01h	NFCID2	PAD0	PAD1	MRTICHECK	MRTIUPDATE	PAD2	[RD]

4.3 Communication with an external microcontroller

The ST25R39xxB communicate with a microcontroller either via an SPI interface or via an I2C interface. On both interfaces the ST25R39xxB act as target devices, relying on the microcontroller to initiate all communication. To notify the microcontroller of completed commands or external events (e.g. peer device field on) the ST25R39xxB signal an interrupt on the IRQ pin. The ST25R39xxB can also provide a configurable clock signal to the microcontroller on the MCU_CLK pin.

4.3.1 Interrupt interface

There are four interrupt registers implemented in the ST25R39xxB:

- [Main interrupt register](#)
- [Timer and NFC interrupt register](#)
- [Error and wake-up interrupt register](#)
- [Passive target interrupt register](#)

When an interrupt condition is met the source of interrupt bit is set and the IRQ pin transitions to high. The microcontroller then reads the [Main interrupt register](#) to distinguish between different interrupt sources. After a particular interrupt register is read, its content is reset to 0.

The IRQ pin transitions to low after the interrupt bit(s) that caused its transition to high has (have) been read.

Note: There may be more than one interrupt bit set if the microcontroller does not immediately read the interrupt registers after the IRQ signal is set and another event causing an interrupt occurs. In this case the IRQ pin transitions to low after the last bit causing interrupt is read. When not using the INT pin, do not read the interrupt status before I_rxs while FIFO count is still zero (fifo_b equals 00).

If an interrupt from a certain source is not required it can be disabled by setting the corresponding bit in the Mask interrupt registers. In case of masking a certain interrupt source the IRQ line is not set high, but the interrupt status bit is still set in IRQ status registers.

Reading the IRQ status registers presents and clears also the masked interrupt bits.

If some interrupts are masked, and set to 1 because of an IRQ event, and later on one of them unmask the IRQ status bit that is already set, the IRQ line is immediately set to high. This notifies the host system that there are some interrupt events not yet read out.

Note: It's recommended to implement a timeout on I_rxe to recover from corrupted frames when I_rxe is not signaled.

Table 10. IRQ output

Name	Signal	Level	Description
IRQ	Digital output	CMOS	Interrupt output pin

IRQ line and IRQ status bits are cleared at:

- Set default
- Reading the IRQ status
- Stop all activities
- Clear FIFO.

FIFO water level and FIFO status registers, FIFO reset

The ST25R39xxB feature a 512 byte FIFO. The control logic shifts the data during transmission, which was previously loaded by the external microcontroller to the framing block and further to the transmitter. During reception, the demodulated data is stored in the FIFO and the external microcontroller can receive data at a later moment.

The *FIFO status register 2* also contains two bits that indicate that the FIFO was not correctly served during TX/RX process (FIFO overflow and FIFO underflow).

A FIFO overflow is set when too many data are written into the FIFO. When this bit is set during RX the external controller did not react on time on the water level IRQ and more than 512 bytes were written into the FIFO (including received CRC bytes). Consequently, the received data is corrupted. When an overflow happens during TX, it means that the controller has written more data than the FIFO size. The data to be transmitted is corrupted.

A FIFO underflow is set when data were read from an empty FIFO. When this bit is set during RX the external controller read more data than was actually received. When an underflow happens during TX, it means that the controller has failed to provide the quantity of data defined in the number of transmitted bytes registers on time.

FIFO pointers and FIFO status are reset at the start of each data reception (at I_rxs). They are also reset at Power-up and at commands Set Default and Clear FIFO. Reading out data from empty/cleared fifo shows data = 0.

MCU_CLK

The pin MCU_CLK may be used as clock source for the external microcontroller. Depending on the operation mode either a low frequency clock (32 kHz) from the RC oscillator or the clock signal derived from crystal oscillator is available on pin MCU_CLK. The MCU_CLK output pin is controlled by bits out_c<1:0> and If_clk_off in the *IO configuration register 1*. Bits out_c<1:0> enable the use of pin MCU_CLK as clock source and define the division when the crystal oscillator is running (13.56, 6.78 and 3.39 MHz are available). Bit If_clk_off controls the use of low frequency clock (32 kHz) when the crystal oscillator is not running. By default configuration, which is defined at power-up, the 3.39 MHz clock is selected and the low frequency clock is enabled.

If the Transparent mode (see *Section 4.4.13*) is used the use of MCU_CLK is mandatory since a clock synchronous with the field carrier frequency is needed to implement receive and transmit framing in the external controller. The use of MCU_CLK is recommended also when the internal framing is used. Using MCU_CLK as the microcontroller clock source generates noise, synchronous with the reader carrier frequency and therefore filtered out by the receiver, while using some other incoherent clock source may produce noise that perturbs the reception. Use of MCU_CLK is also better for EMC compliance.

4.3.2 Communication interface selection

The active communication interface is selected via the I2C_EN pin. If this pin is pulled to GND, the ST25R39xxB operate in SPI mode. If this pin is pulled to V_{DD_D}, the ST25R39xxB operate in I2C mode.

4.3.3 Serial peripheral interface (SPI)

The ST25R39xxB have a standard serial peripheral interface with clock polarity of 0, a clock phase of 1, and an active low target select signal. Communication starts with the MCU pulling BSS low. The MOSI pin is samples on the falling edge of SCLK, and the state of the MISO pin is updated on the rising edge of the SCLK signal. Data is transferred byte-wise, most significant bit first. Read and Write commands support an address auto increment to reduce communication time. [Table 11](#) provides an overview of the SPI signals.

Table 11. Serial data interface (4-wire interface) signal lines

Name	Signal	Signal level	Description
I2C_EN	Digital input	CMOS	Pull to GND for SPI operation
BSS	Digital input		Active low - target select
MOSI	Digital input		Controller out - target in (MCU → ST25R39xxB)
MISO	Digital output with tristate		Controller in - target out (ST25R39xxB → MCU)
SCLK	Digital input		Serial clock
IRQ	Digital output		Active high - Interrupt output pin

The MISO output is in tristate as long as no output data is available. Due to this the MOSI and the MISO can be externally shorted to create a three-wire SPI. During the time the MISO output is in tristate, it is also possible to switch on a 10 kΩ pull down by activating option bits miso_pd1 and miso_pd2 in the [IO configuration register 2](#).

Figure 14. Exchange of signals with a microcontroller

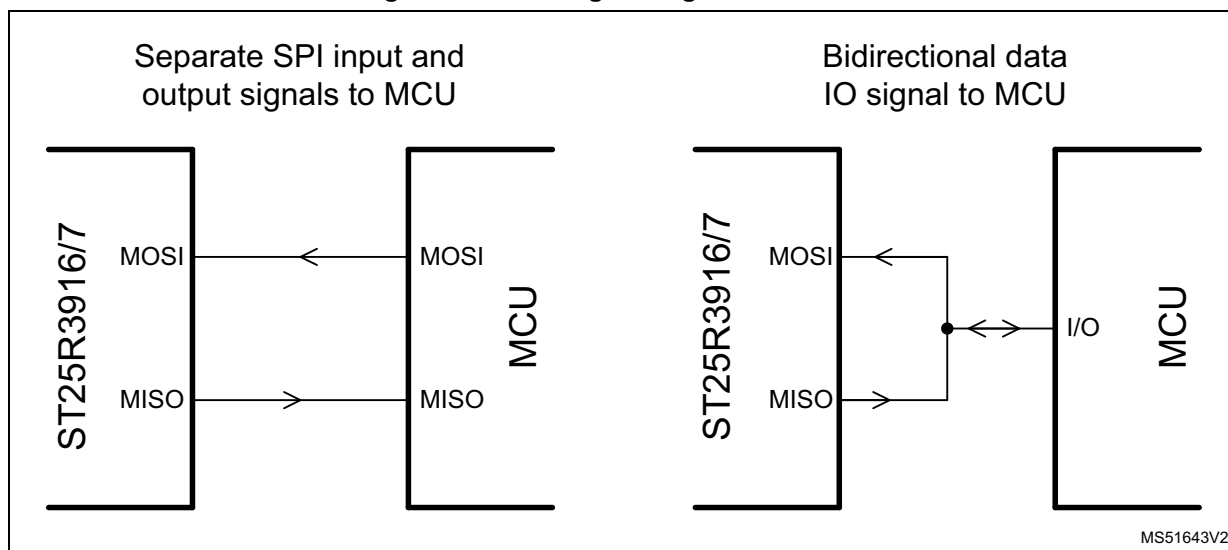

The first two bits of the first byte transmitted after the BSS high to low transition define the SPI operation mode. All Read and Write modes support address auto incrementing, which means that if, after the address and first data byte some additional data bytes are sent (or read), they are written to (or read from) addresses incremented by 1.

Table 12 shows available SPI operation modes. Register read and write operations are possible in all ST25R39xxB operation modes. FIFO and PT_memory operations are possible in case en (bit 7 of the *Operation control register*) is set and the crystal oscillator is stable.

Some direct commands are accepted in all operation modes, others require en (bit 7 of the *Operation control register*) to be set and the crystal oscillator to be stable (see Table 14).

Table 12. SPI operation modes

Mode	Pattern (communication bits)								Related data
	Mode		Trailer						
	M1	M0	C5	C4	C3	C2	C1	C0	
Register write	0	0	A5	A4	A3	A2	A1	A0	Data byte (or more bytes in case of auto-incrementing).
Register read	0	1	A5	A4	A3	A2	A1	A0	
FIFO load	1	0	0	0	0	0	0	0	One or more bytes of FIFO data.
PT_memory load A-config	1	0	1	0	0	0	0	0	Passive target memory, locations from 0 on.
PT_memory load F-config	1	0	1	0	1	0	0	0	Passive target memory, locations from 15 on.
PT_memory load TSN data	1	0	1	0	1	1	0	0	Passive target memory, locations from 36 on. The additional address allows reload of the TSN random numbers without rewriting the whole PT_memory.
PT_memory read	1	0	1	1	1	1	1	1	Passive target memory, locations from 0 on. A 0 byte is presented to the passive target memory to support reading at all SPI speeds.
FIFO read	1	0	0	1	1	1	1	1	One or more bytes of FIFO data
Direct command	1	1	C5	C4	C3	C2	C1	C0	-

Writing data to addressable registers (Write mode)

Figure 15 and Figure 16 show cases of writing, respectively, a single byte and multiple bytes with auto-incrementing address. After the SPI operation mode bits, the address of register to be written is provided. Then one or more data bytes are transferred from the SPI, always MSB to LSB. The data byte is written in register on falling edge of its last clock. If the register on the defined address does not exist or it is a read only register no write is performed.

Figure 15. SPI communication: writing a single byte

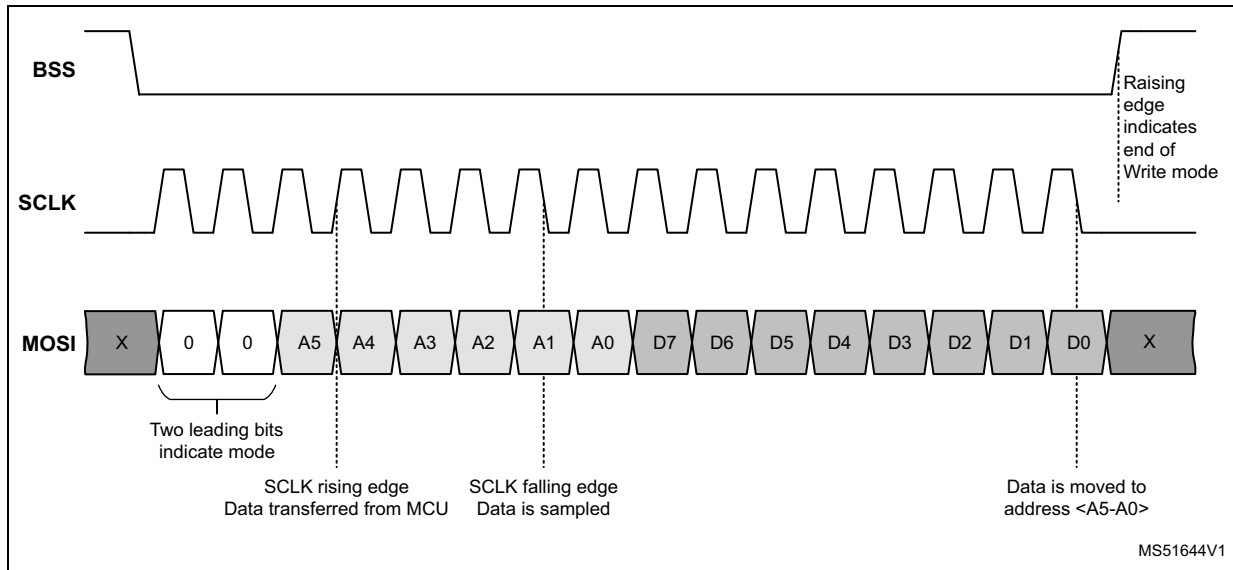
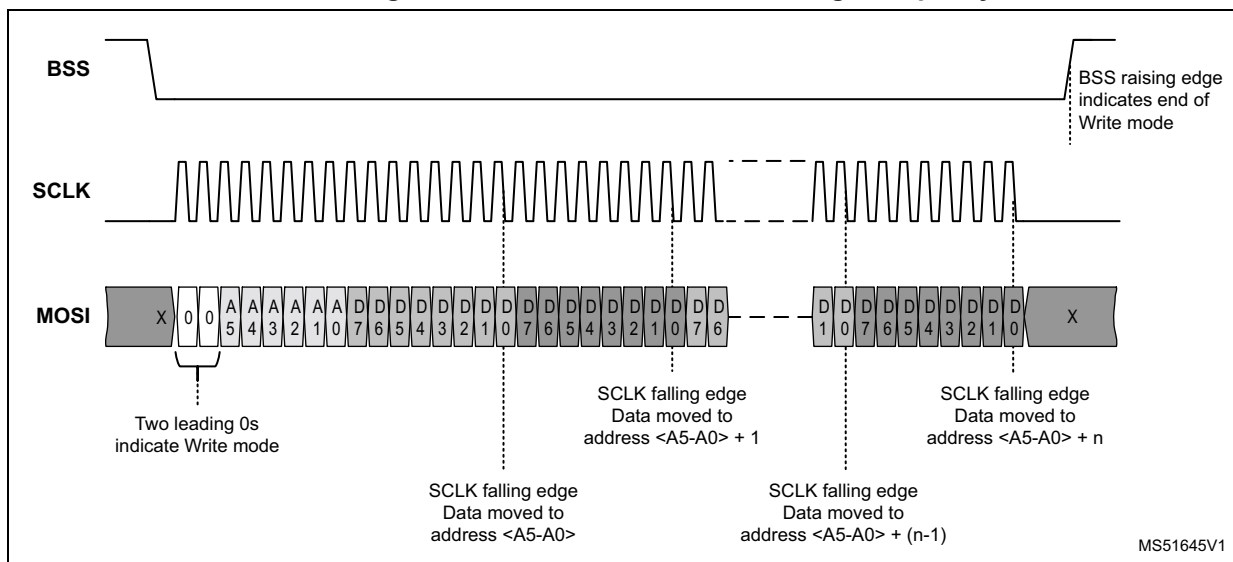

Figure 16. SPI communication: writing multiple bytes



Reading data from addressable registers (Read register mode)

The SPI operation mode bits are followed by the address of the register to be read. Then one or more data bytes are transferred to MISO output (MSB first) for as long as SCLK is present. This mode also supports address auto-incrementing. If there is no register at a certain address, then all 0 data is sent to MISO.

Figure 17 is an example of reading a single byte.

Figure 17. SPI communication: reading a single byte

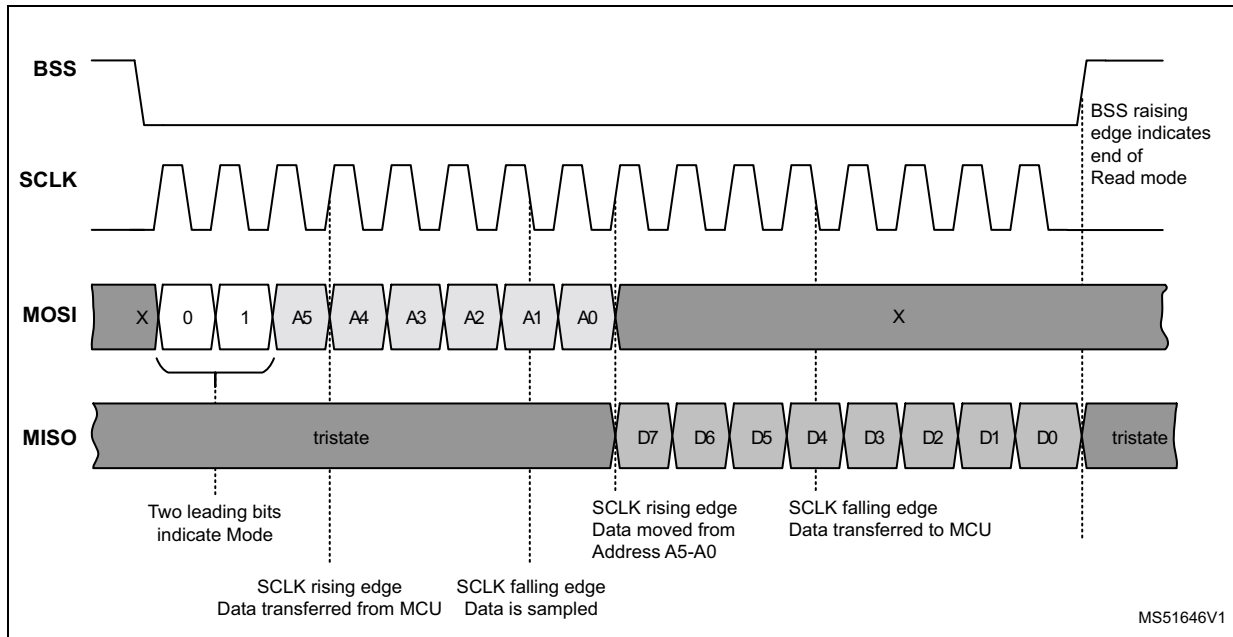

Read or write access to register space-B

To access the register space-B the register read or write SPI sequence has to be prefixed with the byte FBh. Access to register space-B remains active until the rising edge of BSS.

Loading transmitting data into FIFO

Loading the transmitting data into the FIFO is similar to writing data into an addressable registers. The SPI sequence starts with SPI operation mode bits '10' to indicate a FIFO operation followed by bits <C5:C0> set to 000000b. After the FIFO mode byte at least one and up to 512 data bytes must be sent.

Figure 18 shows how to load the transmitting data into the FIFO.

Figure 18. SPI communication: FIFO loading

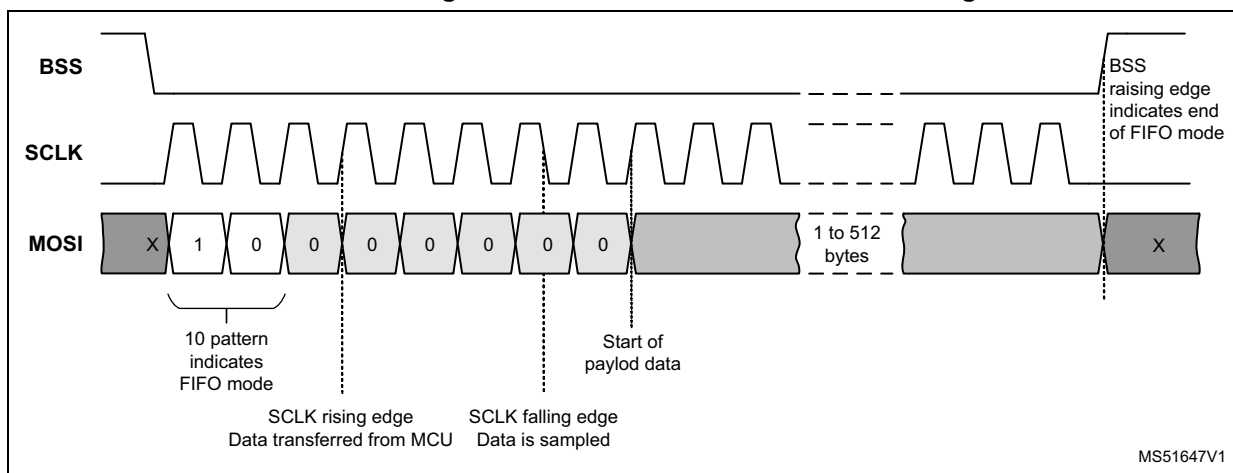

Reading received data from FIFO

Reading received data from the FIFO is similar to reading data from an addressable registers. The SPI sequence starts with SPI operation mode bits '10' to indicate a FIFO operation followed by <C5:C0> set to 011111b. After the mode byte the ST25R39xxB output the data from the FIFO as long as SCLK is present and BSS is kept low.

Figure 19. SPI communication: FIFO reading

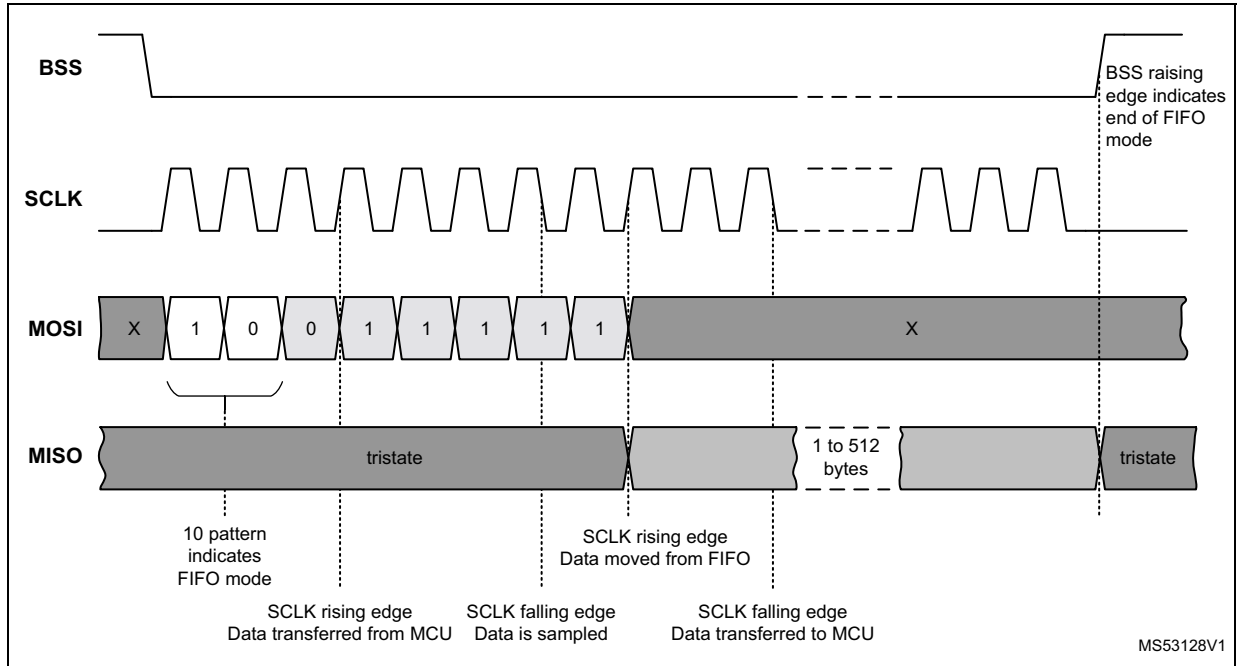

Direct command mode

Direct command mode has no arguments, so a single byte is sent. The byte starts with the SPI operation mode bits '11' to indicate Direct Command Mode followed by the direct command code (see [Table 14](#)) in <C5:C0>, MSB first. Execution of the direct command starts with the rising edge of BSS (see [Figure 20](#)).

While the execution of some direct commands is immediate, there are others that start a process of certain duration (e.g. calibration, measurements). During the execution of such commands it is not allowed to start another activity over the SPI interface, an IRQ is sent. when the execution is terminated.

Figure 20. SPI communication: direct command

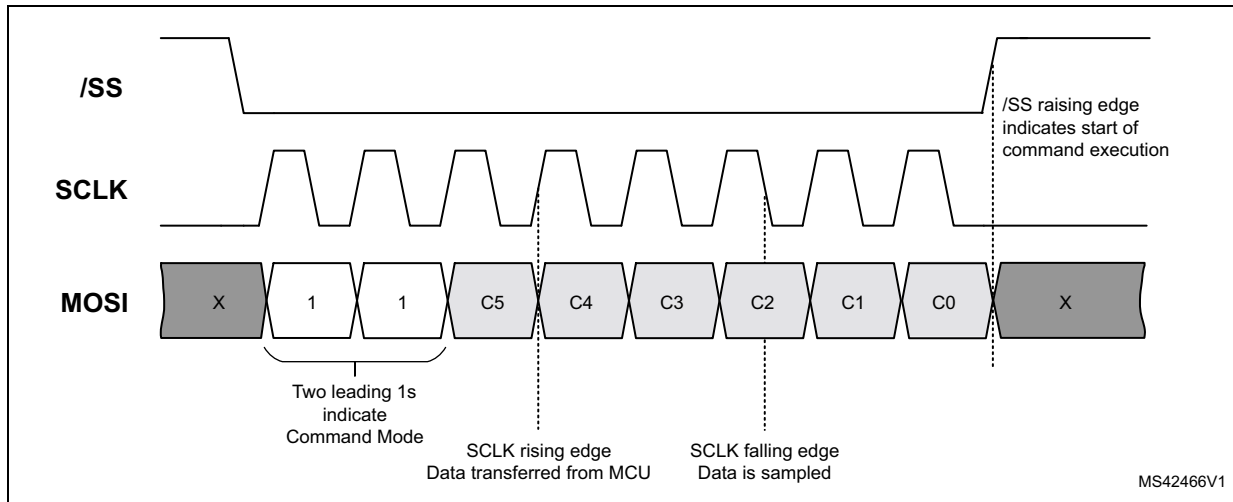

Direct command chaining

As shown in [Figure 21](#), direct commands with immediate execution can be followed by another SPI mode (Read, Write or FIFO) without deactivating the BSS signal in between.

Figure 21. SPI communication: direct command chaining

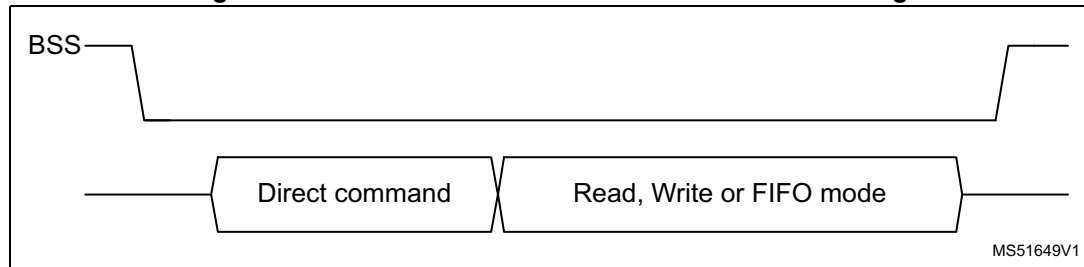

Loading data in the PT_Memory (PT_Memory load)

Loading data into the PT_Memory is similar to loading data into the FIFO. There are three mode patterns available to load data into three different parts of the PT_memory, as indicated in [Table 12](#). The first byte following the mode/address pattern is stored in the location detailed in [Table 12](#), for consecutive bytes the address is automatically incremented and data are stored to consecutive addresses.

The user must take care that the number of loaded bytes fits the size of the selected PT_memory area, not to overwrite data in the following PT_memory areas.

4.3.4 I2C interface

The I2C address is 50h. This interface supports:

- Standard mode (100 kHz)
- Fast mode (400 kHz)
- Fast mode Plus (1 MHz)
- High speed mode (3.4 MHz).

[Table 13](#) summarizes the I2C interface signals.

Table 13. I2C interface and interrupt signal lines

Name	Signal	Signal level	Description
I2C_EN	Digital input	CMOS	Pull to V _{DD_D} for I2C operation
MISO (SDA)	Digital output		I2C data line
SCLK (SCL)	Digital input		I2C clock
IRQ	Digital output		Active high - Interrupt output pin

Writing data to addressable registers (Register Write mode)

After the I2C target address the address of the register to be written is sent using the same Register Write mode byte as for SPI register write access. The Register Write mode byte is then followed by one or more data bytes. If more than one data byte is sent, the data is stored in subsequent registers starting from the initial register address by incrementing the target address by one for each new data byte.

Figure 22 and Figure 23 show, respectively, how to write a single byte into a register and how to write multiple bytes into subsequent registers using address auto-incrementing.

Figure 22. Writing a single register

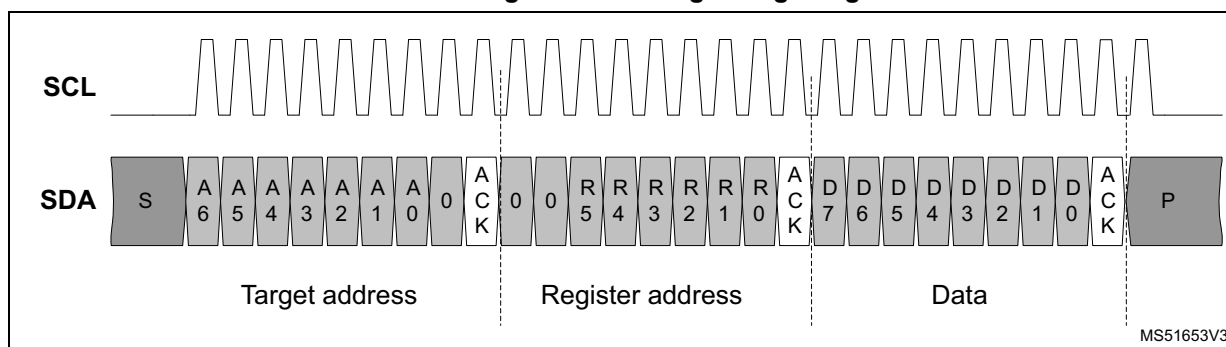
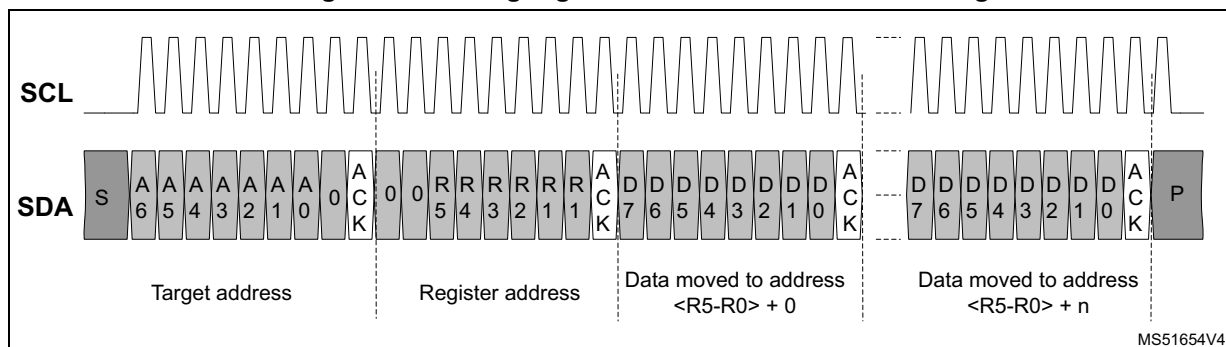

Figure 23. Writing register data with auto-incrementing address



Reading data from addressable registers (Register Read mode)

After the I2C target address the address of the register to be read is sent using the same Register Read mode byte of the SPI register read access. After the Register Read mode byte the ST25R39xxB send data bytes to the SDA output as long as the MCU keeps SCL. The Register Read mode also supports address auto-incrementing. If the addressed register does not exist, all 0 data is sent to SDA.

Figure 24 shows how to read a single byte from a register.

Figure 24. Reading a single byte from a register

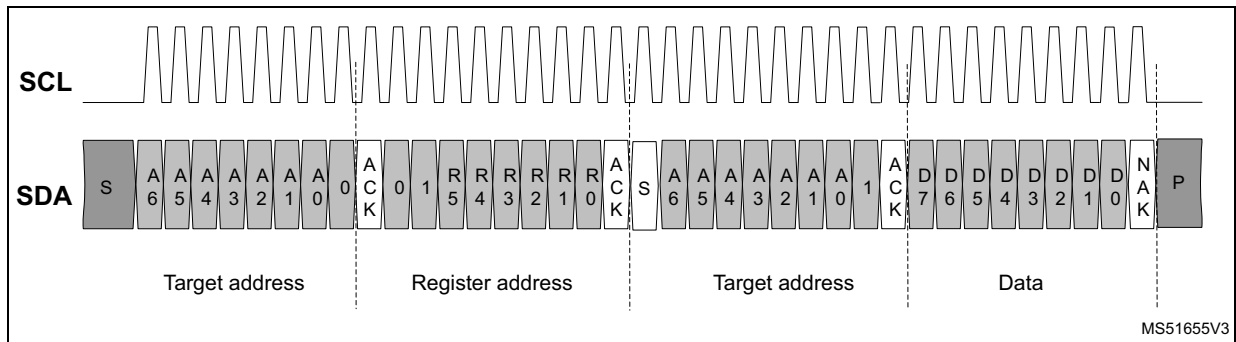

Loading data into FIFO or PT_Memory (FIFO/PT_Memory load)

Loading data into FIFO or PT_Memory is similar to writing data into addressable registers. After the I2C target address the mode byte to trigger a load of the FIFO or selected PT_Memory area is sent (see Table 12) followed by the data bytes to be loaded.

Figure 25 shows how to load data into the FIFO.

Figure 25. FIFO load

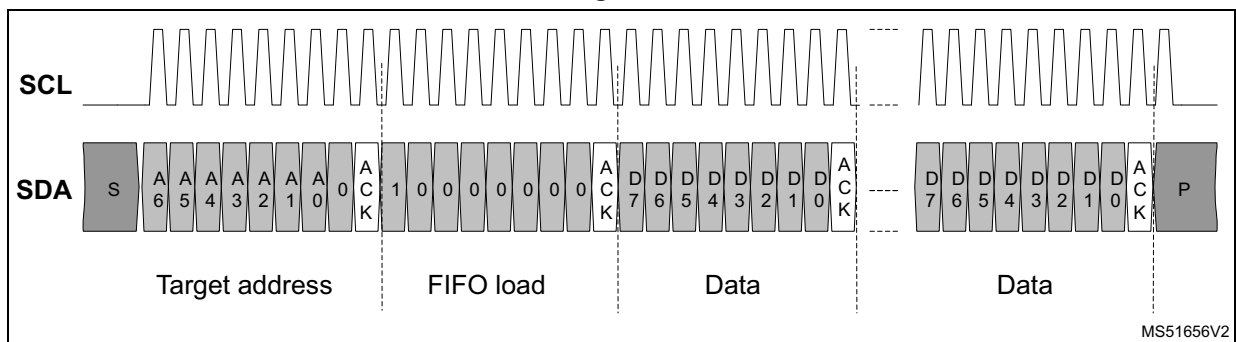

Reading data from the FIFO

Reading data from the FIFO is similar to reading data from addressable registers. After the I2C target address the mode byte to trigger a read of the FIFO is sent. After receiving the FIFO read mode byte the ST25R39xxB send data bytes from the FIFO for as long as the MCU keeps reading the bus.

Figure 26. FIFO read

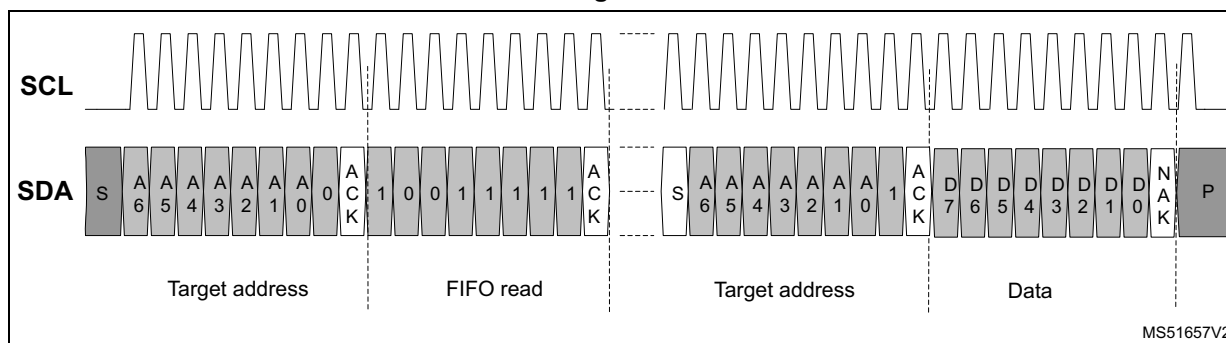

Direct command mode

After the I2C target address the mode byte to trigger a direct command is sent. As for SPI some direct commands take some time to execute and no I2C access to the ST25R39xxB must be performed until the execution of the direct command is completed. All such direct commands send an interrupt upon completion to notify the MCU that the I2C bus can be used again.

Figure 27. Sending a direct command

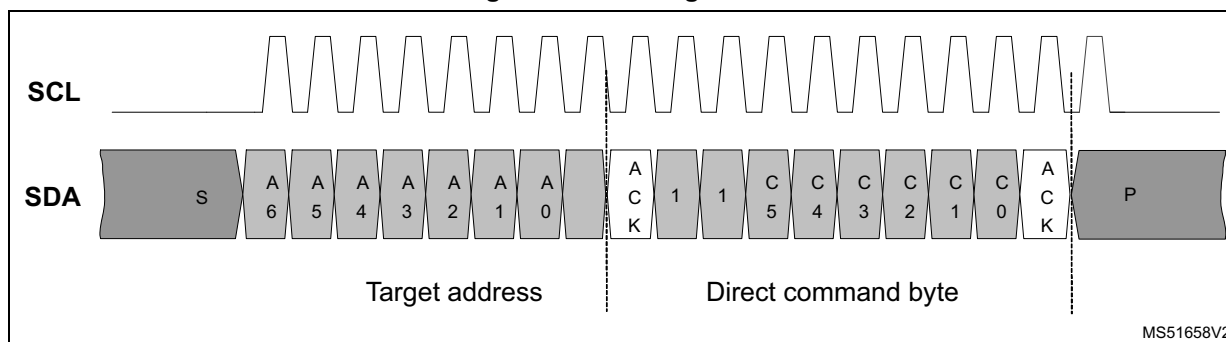

I2C access to register space-B

To access the register space-B, byte FBh has to be inserted between the I2C target address and the register read or write mode byte. Access to register space-B remains active until an I2C Stop Condition is received.

Figure 28. Read and Write mode for register space-B access

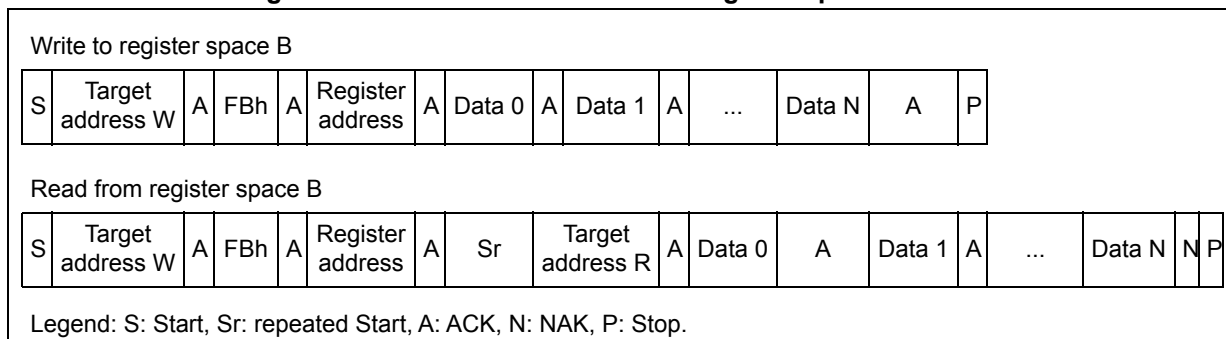

I2C: transition to and termination of the Transparent mode

When the transparent mode command is received via I2C, the chip interface lines are switched to the Analogue front end as described in [Section 4.4.13: Transparent mode](#).

Once in transparent mode the BSS signal is used to distinguish between I2C communication and transparent mode data as follows:

1. the BSS line must be set high before entering the transparent mode, and then kept high during the Transparent mode
2. the Transparent mode is terminated when the BSS line is set to low, followed by at least one SCL clock pulse
3. after the termination of the transparent mode the I2C interface can be used again.

I2C: controller reads target immediately after the first byte

If the I2C controller omits the mode byte and reads the ST25R39xxB immediately after the target address, then, as shown in [Figure 29](#), it will first output the byte FFh, followed by a register dump starting at address 01h.

Figure 29. I2C controller reads target immediately after the first byte

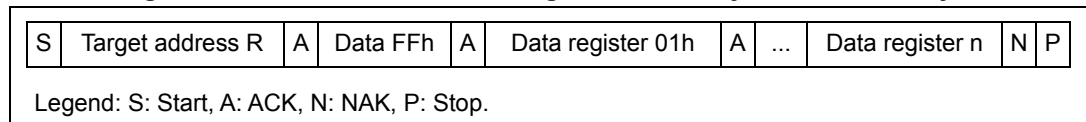

This mode is incorporated for an easier the detection of I2C devices, but is not intended to be used in normal operation.

4.4 Direct commands

Table 14. List of direct commands

Code (hex)	Name	Comments	Chaining	Interrupt after termination	Operation mode ⁽¹⁾
C0, C1	Set default	Puts the ST25R3916B into power-up state	No	No	All
C2, C3	Stop all activities	Stops all activities: transmission, reception, direct command execution, timers	Yes	No	en
C4	Transmit with CRC	Starts a transmit sequence with automatic CRC generation	Yes	No	en
C5	Transmit without CRC	Starts a transmit sequence without automatic CRC generation	Yes	No	en
C6	Transmit REQA	Transmits REQA command (ISO14443A mode only)	Yes	No	en, tx_en
C7	Transmit WUPA	Transmits WUPA command (ISO14443A mode only)	Yes	No	en, tx_en
C8	NFC initial field ON	Performs Initial RF Collision avoidance and switches on the field	Yes	Yes	en

Table 14. List of direct commands (continued)

Code (hex)	Name	Comments	Chaining	Interrupt after termination	Operation mode ⁽¹⁾
C9	NFC response field ON	Performs Response RF Collision avoidance and switches on the field	Yes	Yes	en
CD	Go to sense (Idle)	Puts the passive target logic into Sense (Idle) state	Yes	No	en, rx_en
CE	Go to sleep (Halt)	Puts the passive target logic into Sleep (Halt) state	Yes	No	en, rx_en
D0	Mask receive data	Stops receivers and RX decoders	Yes	No	All
D1	Unmask receive data	Starts receivers and RX decoders	Yes	No	All
D2	Change AM modulation state	Changes AM modulation state	Yes	No	en, tx_en
D3	Measure amplitude	Measures the amplitude of the signal present on RFI inputs and stores the result in the A/D converter output register	No	Yes	All ⁽²⁾
D5	Reset RX gain	Resets receiver gain to the value in the Receiver configuration register 4	No	No	en
D6	Adjust regulators	Adjusts supply regulators according to the current supply voltage level	No	Yes	en
D8	Calibrate driver timing	Starts the driver timing calibration according to the setting in the TX driver timing display register	No	No	en
D9	Measure phase	Measures the phase difference between the signal on RFO and RFI	No	Yes	All ⁽²⁾
DA	Clear RSSI	Clears the RSSI bits in the RSSI display register and restarts the measurement	Yes	No	en
DB	Clear FIFO	Clears FIFO	Yes	No	en
DC	Enter Transparent mode	Enters in Transparent mode	No	No	en
DF	Measure power supply	-	No	Yes	en
E0	Start General purpose timer	-	Yes	No	en
E1	Start Wake-up timer	-	Yes	No	All except wu
E2	Start Mask-receive timer	Starts the mask-receive timer and squelch operation	Yes	No	en
E3	Start No-response timer	-	Yes	No	en
E4	Start PP _{ON2} timer	-	Yes	No	en
E8	Stop No-response timer	-	Yes	No	en
EA	Trigger RC calibration	-	No	Yes	en

Table 14. List of direct commands (continued)

Code (hex)	Name	Comments	Chaining	Interrupt after termination	Operation mode ⁽¹⁾
FB	Register space-B access	Enables R/W access to register Space-B	Yes	No	all
FC	Test access	Enable R/W access to Test register	Yes	No	All
Other codes	RFU	Not used	-	-	-

1. Defines which *Operation control register* bits have to be set in order to accept a particular command.
2. Measure amplitude and Measure phase can be used directly from power down mode. In this case the command temporarily enables the oscillator.

4.4.1 Set default

This direct command puts the ST25R39xxB in the same state as power-up initialization:

- performs *Stop all activities* command
- resets all registers to their default state
- clears all collision bits

Results of previous calibration and adjust commands are lost. No IRQ due to termination of direct command is produced.

4.4.2 Stop all activities

This direct command stops any ongoing activities:

- performs *Clear FIFO* command
- stops data transmission and reception
- stops all timers, including FDT timer
- clears IRQ line and IRQ status bits
- stops Field ON commands

If Stop All Activities is received during RF collision avoidance the field detection is terminated and field is not set, consequently no interrupts are sent

- stops automatic field ON (same as above)
- stops automatic field OFF

If Stop All Activities is received during waiting for automatic field off via GPT, the field remains on

- nfc_ar is set to 01b, then it clears the awareness that there was a previous reception
- stops Temporary Enable

This command does not update any register apart from the FIFO status registers. Therefore it does not disable the field detector in CE mode (if it was enabled), and it does not switch off the field (if it was enabled).

4.4.3 Clear FIFO

This direct command clears the FIFO and the FIFO status registers. It does not clear the IRQ line or IRQ status bits.

To prepare a transmission send this command first before writing data into the FIFO. If a Clear FIFO command is sent during an ongoing data transmission, then the data transmission is aborted and FIFO and FIFO status registers are cleared.

4.4.4 Transmit commands

The transmit direct commands are used to start a data transmission from the ST25R39xxB. They switch the device to reception mode after the transmission is completed.

Before sending commands Transmit with CRC and Transmit without CRC, direct command Clear FIFO has to be sent, followed by the definition of the number of transmitted bytes and writing data to be transmitted in FIFO.

Use the direct commands Transmit REQA and Transmit WUPA to transmit ISO14443A short frame commands REQA and WUPA respectively. It is not necessary to send the direct command Clear FIFO before these two commands.

If the antcl bit is set, then the number of valid bits in the last byte must be set to 0 (nbtx<2:0> in the [Number of transmitted bytes register 2](#)) prior to the direct command Transmit REQA or Transmit WUPA.

The direct commands Transmit REQA and Transmit WUPA automatically disable the CRC check of the response frame. The CRC check is enabled again after any of the below conditions:

- Transmit with CRC direct command
- Mask receive data direct command
- No Response timer expires

If the direct command Transmit without CRC is used in Felica™ mode the Length and CRC bytes are skipped. After the preamble and Sync bytes the raw FIFO content is transmitted. A transmit length nbtx<2:0> ≥ 1 must be used.

4.4.5 NFC field ON commands

The NFC field ON direct commands are used to perform RF Collision Avoidance. The external field detector must be enabled for these commands to work correctly.

Note: It is recommended that bits en_fd_c<1:0> of the operation control register are set to 01b in Reader mode. In the NFCIP-1 active communication (AP2P), the bits en_fd must be set to 11b to enable an external field detector automatically. So that the external field detector automatically exchanges its threshold between collision avoidance and peer detection level, as needed, during operation. Collision avoidance and peer detection levels must be tuned (in accordance with environmental temperature) to ensure good working conditions. In AP2P mode, a minimum collision avoidance and peer detection activation threshold of 205 mV_{PP} is recommended for bits rfe_t<3:0> and trg_l<3:0> of the external field detector activation threshold register.

To determine whether an external field is present the ST25R39xxB compares the RF voltage level on the RF11 pin with the collision avoidance threshold defined in the [External field detector activation threshold register](#).

If no external field is detected, then the ST25R39xxB transmitter is switched on automatically (bit tx_en in the [Operation control register](#) is set) and an I_apon IRQ is signaled. After the RF guard time defined in the [NFC field on guard timer register](#) has passed an I_cat IRQ is signaled. At this point the controller can initiate a data transmission using a transmit command.

If an external field is detected a I_cac IRQ is signaled, and the ST25R39xxB transmitter stays off.

The direct command NFC initial field ON performs an Initial collision avoidance according to NFCIP-1 standard, and the direct command NFC response field ON performs a Response collision avoidance according to NFCIP-1 standard. See [Figure 30](#), [Figure 31](#) and [Table 15](#) for details on the timing of these commands.

Figure 30. Direct command NFC initial field ON

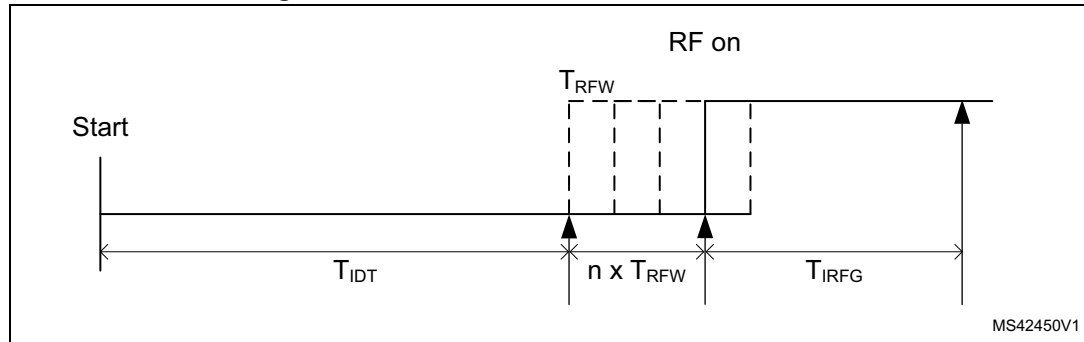

Figure 31. Direct command NFC response field ON

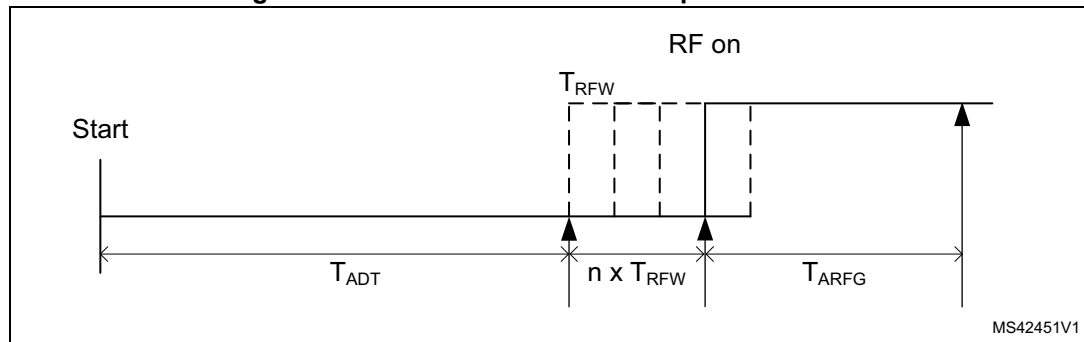

Table 15. Timing parameters of NFC field ON commands

Parameter	Symbol	Value	Unit	Notes
Initial delay time	T_{IDT}	4096	/ fc	NFC initial field ON
RF waiting time	T_{RWF}	512	/ fc	$n = 0 \dots 3$ based on <code>nfc_n<1:0></code>
Initial guard time	T_{IRFG}	75 μ s + NFC field on guard time	s	NFC field on guard time defined in the NFC field on guard timer register . NFCIP-1 T_{IRFG} requirement: 5 ... 35 ms
Active delay time	T_{ADT}	768	/ fc	NFC response field ON
RF waiting time	T_{RWF}	512	/ fc	$n = 0 \dots 3$ based on <code>nfc_n<1:0></code> in Auxiliary definition register
Active guard time	T_{ARFG}	75 μ s + NFC field on guard time	s	NFC Field ON guard time defined in the NFC field on guard timer register . NFCIP-1 T_{ARFG} requirement: > 75 μ s + NFC field ON guard times (1024 / fc)

4.4.6 Mask receive data and Unmask receive data

The direct command Mask receive data disables processing of the receiver output by the RX decoders, RSSI measurement, and AGC operation.

The direct command Unmask receive data enables processing of the received data by the RX decoders, RSSI measurement and AGC operation. A common use of this command is to re-enable the receiver operation after it was masked by the command Mask receive data. If the Mask receive timer is still running while the direct command Unmask receive data is received, reception is enabled, and the Mask receive timer is reset.

In passive target (card emulation) mode, the Unmask receive data command prepares the RX decoders for a new data reception and clears the internal FDT timer. In passive target mode, this direct command must be used only if no further transmissions from the ST25R39xxB are planned and the devices have to wait for the next command to be received.

4.4.7 Change AM modulation state

This command changes the AM modulation state from unmodulated to modulated, and vice versa. This can be used to measure the AM modulation index with the direct command [Measure amplitude](#).

4.4.8 Measure amplitude

This command measures the amplitude of the RF signal on the RFI inputs and stores the result in the [A/D converter output register](#).

This command enables the transmitter and amplitude detector. The transmitter drives the antenna, and the amplitude detector converts the differential RF signal received back between RFI1 and RFI2 into a proportional DC voltage. This DC voltage is converted with the A/D converter in absolute conversion mode into an 8-bit value and stored in the [A/D converter output register](#).

The amplitude detector conversion gain is $0.6 V_{inPP} / V_{out}$ referenced to the RF signal on a single RFI pin. Thus, one LSB of the A/D converter output represents 13.02 mV_{PP} on either of the RFI inputs.

Note: The maximum allowed voltage level on an RFI pin is 3 V_{PP}. This results in 1.8 V output DC voltage of the amplitude detector and produces a value of E6h after A/D conversion.

Duration time: 25 µs max.

4.4.9 Reset RX gain

This command initializes the AGC, Squelch and RSSI block and resets the gain reduction to the value set in [Receiver configuration register 4](#). Sending this command also stops any ongoing squelch process.

4.4.10 Adjust regulators

When this command is sent, then the transmitter and receiver are enabled to ensure a high current draw and the regulated voltage V_{DD_RF} is set 250 mV below the power supply level of V_{DD_TX}. Before sending the adjust regulator command it is required to toggle the bit reg_s by setting it first to 1 and then reset it to 0. After the adjustment is completed the state of the

transmitter and receiver prior to the command execution is restored (either enabled or disabled).

Duration time: 5 ms max.

This command is not accepted if external definition of the regulated voltage is selected in the *Regulator voltage control register* (bit `reg_s` is set to 1).

4.4.11 Measure phase

This command measures the phase difference between the signals on the RFO outputs and the signals on the RFI inputs and stores the result in the *A/D converter output register*.

This command enables the transmitter and phase detector, and performs an A/D conversion of the output of the phase detector with the A/D converter in relative mode. The phase measurement results can be calculated using the following formulas:

- $0 \leq \Phi \leq 17^\circ$: result = 255
- $17 < \Phi < 163^\circ$: angle [°] = $17 + (1 - \text{result} / 255) * 146$
- $163 \geq \Phi \geq 180^\circ$: result = 0

Duration time: 25 μ s max.

4.4.12 Clear RSSI

The receiver automatically clears the RSSI bits in the *RSSI display register* and starts a new measurement of the RSSI when a new reception is started (e.g. after a Transmit direct command). Since the RSSI bits store the peak value (peak-hold type) eventual variation of the receiver input signal will not be followed (this may happen in case of a long message or test procedure).

The direct command Clear RSSI clears the RSSI bits in the *RSSI display register*, and restarts the RSSI measurement. This allows to obtain multiple RSSI measurements during a single reception.

4.4.13 Transparent mode

This command sets the receiver and transmitter into the transparent mode. The device enters the transparent mode on the rising edge of the BSS signal of the SPI frame used to send the direct command. The transparent mode is maintained as long as signal BSS is kept high, that is, the following SPI command sent from the microcontroller will automatically stop the transparent mode.

4.4.14 Measure power supply

This command measures the power supply. The bits `mpsv<2:0>` in the *Regulator voltage control register* select which signal is measured. The result of the measurement is stored in the *A/D converter output register*.

For power supply measurements the selected supply input voltage is divided by three and measured with the A/D converter in absolute mode. This leads to a resolution of 23.4 mV per LSB for all power supply measurements.

Duration time: 25 μ s max.

4.4.15 Trigger RC calibration

The command triggers the RC calibration cycle for the active waveshaping filter constant. The result can be read in AWS time 6 register and IRQ I_dct signals end of calibration.

The Trigger RC calibration command should be triggered once after device power-on and set default direct command. The RC calibration should not be triggered during data transmission or reception.

4.4.16 Test access

The devices do not have dedicated test pins. A direct command Test Access is used to enable RW access of test registers and entry in different test modes. Pins TAD1 and TAD2 are used as test pins.

Test mode entry and access to test registers

Test registers are not part of the normal register address space. After sending direct command Test Access, test registers can be accessed using normal Read/Write register command. Access to test registers is possible in a chained command sequence where command Test Access is sent first, followed by read/write access to test registers using auto increment feature. Test register are set to default state at power-up.

Analog test and observation register 1

Address: 01h

Type: RW

Table 16. Analog test and observation register 1

Bit	Name	Default	Function	Comments
7	tana7	0	-	Reserved
6	tana6	1	-	Reserved
5	tana5	0	-	Reserved
4	-	0	-	Reserved
5	tana3	0	See Table 17	These test modes are also intended for observation in normal mode. Other modes of this register are also available when analog test mode is not set.
4	tana2	0		
3	tana1	0		
0	tana0	0		

Table 17. Test access register - Signal selection of TAD1 and TAD2 pins⁽¹⁾

tana3:0 (hex)	Pin TAD1		Pin TAD2		
	Type	Functionality	Type	Functionality	Comment
1	A0	Analog output of AM channel (before digitizer)	D0	Digital output of AM channel (after digitizer)	Normal operation (reader)
2	A0	Analog output of PM channel (before digitizer)	D0	Digital output of PM channel (after digitizer)	
3	A0	Analog output of AM channel (before digitizer)	A0	Analog output of PM channel (before digitizer)	
4	A0	Analog output of AM correlation signal	A0	Analog output of PM correlation signal	
5	A0	Tag demodulator analog	D0	Tag demodulator OOK digital out	Normal operation (tag)
6	A0		D0	Tag demodulator ASK digital out	
7	A0	Analog voltage of amplitude measurement	D0	Analog voltage of phase measurement	m_amp_ana and m_phase_ana in Rs-A, Reg 3Bh define which is active
B	D0	Digital output of AM correlation data signal	D0	Digital output of AM correlation collision/start detection signal	-
C	D0	Digital output of PM correlation data signal	D0	Digital output of PM correlation collision/start detection signal	-
D	A0	Analog output of AM correlation signal	A0	Correlation digitizing threshold for AM channel	-
E	A0	Analog output of PM correlation signal	A0	Correlation digitizing threshold for PM channel	-

1. Set en=1 and rx_en=1 in Operation control register before enabling tana<3:0> test modes.

4.5 Registers

The ST25R39xxB have two register spaces, each of them consists of up to 64 registers with address ranging from 00h to 3Fh:

1. register space A (Rs-A), see [Table 18](#)
2. register space B (Rs-B), see [Table 19](#).

There are two types of registers implemented in the ST25R39xxB:

1. configuration registers: used to configure the device, can be written and read through the SPI or I2C interfaces
2. display registers: read only (RO), contain information about the state of the device.

Registers are set to their default value at power-up and after sending the direct command [Set default](#). Bits set as RFU must be kept at their reset values unless otherwise specified.

Table 18. List of registers - Space A

Type	Address (hex)	Register space A (Rs-A)
IO configuration	00	<i>IO configuration register 1</i>
	01	<i>IO configuration register 2</i>
Operation control and mode definition	02	<i>Operation control register</i>
	03	<i>Mode definition register</i>
	04	<i>Bit rate definition register</i>
Protocol configuration	05	<i>ISO14443A and NFC 106kb/s settings register</i>
	06	<i>ISO14443B settings register 1</i>
	07	<i>ISO14443B and FeliCa settings register</i>
	08	<i>NFCIP-1 passive target definition register</i>
	09	<i>Stream mode definition register</i>
	0A	<i>Auxiliary definition register</i>
Receiver configuration	0B	<i>Receiver configuration register 1</i>
	0C	<i>Receiver configuration register 2</i>
	0D	<i>Receiver configuration register 3</i>
	0E	<i>Receiver configuration register 4</i>
Timer definition	0F	<i>Mask receive timer register</i>
	10	<i>No-response timer register 1</i>
	11	<i>No-response timer register 2</i>
	12	<i>Timer and EMV control register</i>
	13	<i>General purpose timer register 1</i>
	14	<i>General purpose timer register 2</i>
	15	<i>PPON2 field waiting register</i>
Interrupt and associated reporting	16	<i>Mask main interrupt register</i>
	17	<i>Mask timer and NFC interrupt register</i>
	18	<i>Mask error and wake-up interrupt register</i>
	19	<i>Mask passive target interrupt register</i>
	1A	<i>Main interrupt register</i>
	1B	<i>Timer and NFC interrupt register</i>
	1C	<i>Error and wake-up interrupt register</i>
	1D	<i>Passive target interrupt register</i>
	1E	<i>FIFO status register 1</i>
	1F	<i>FIFO status register 2</i>
20	<i>Collision display register</i>	
21	<i>Passive target display register</i>	

Table 18. List of registers - Space A (continued)

Type	Address (hex)	Register space A (Rs-A)
Definition of number of transmitted bytes	22	<i>Number of transmitted bytes register 1</i>
	23	<i>Number of transmitted bytes register 2</i>
	24	<i>Bit rate detection display register</i>
A/D converter output	25	<i>A/D converter output register</i>
Antenna calibration	26	<i>Antenna tuning control register 1</i>
	27	<i>Antenna tuning control register 2</i>
Antenna driver and modulation	28	<i>TX driver register</i>
	29	<i>Passive target modulation register</i>
External field detector threshold	2A	<i>External field detector activation threshold register</i>
	2B	<i>External field detector deactivation threshold register</i>
Regulator	2C	<i>Regulator voltage control register</i>
Receiver state display	2D	<i>RSSI display register</i>
	2E	<i>Gain reduction state register</i>
Auxiliary display	31	<i>Auxiliary display register</i>
Wake-up	32	<i>Wake-up timer control register</i>
	33	<i>Amplitude measurement configuration register</i>
	34	<i>Amplitude measurement reference register</i>
	35	<i>Amplitude measurement auto-averaging display register</i>
	36	<i>Amplitude measurement display register</i>
	37	<i>Phase measurement configuration register</i>
	38	<i>Phase measurement reference register</i>
	39	<i>Phase measurement auto-averaging display register</i>
	3A	<i>Phase measurement display register</i>
IC identity	3F	<i>IC identity register</i>

Table 19. List of registers - Space B

Type	Address (hex)	Register space B (Rs-B)
Protocol configuration	05	<i>EMD suppression configuration register</i>
	06	<i>Subcarrier start timer register</i>
Receiver configuration	0B	<i>P2P receiver configuration register 1</i>
	0C	<i>Correlator configuration register 1</i>
	0D	<i>Correlator configuration register 2</i>
Timer definition	0F	<i>Squelch timer register</i>
	15	<i>NFC field on guard timer register</i>

Table 19. List of registers - Space B (continued)

Type	Address (hex)	Register space B (Rs-B)
Antenna driver and modulation	28	<i>Auxiliary modulation setting register</i>
	29	<i>TX driver timing register</i>
External field detector threshold	2A	<i>Resistive AM modulation register</i>
	2B	<i>TX driver timing display register</i>
Regulator	2C	<i>Regulator display register</i>
Active Waveshaping	30	<i>Overshoot protection configuration register 1</i>
	31	<i>Overshoot protection configuration register 2</i>
	32	<i>Undershoot protection configuration register 1</i>
	33	<i>Undershoot protection configuration register 2</i>
	2E	<i>AWS Config 1 register</i>
	2F	<i>AWS Config 2 register</i>
	34	<i>AWS time 1 register</i>
	35	<i>AWS time 2 register</i>
	36	<i>AWS time 3 register</i>
	37	<i>AWS time 4 register</i>
	38	<i>AWS time 5 register</i>
	39	<i>AWS time 6 register</i>

4.5.1 IO configuration register 1

Register space: A

Address: 00h

Type: RW

Table 20. IO configuration register 1

Bit	Name	Default	Function			Comments
7	single	0	0: Differential antenna driving 1: Only one RFO driver will be used			Chooses between single and differential antenna driving.
6	rfo2	0	0: RFO1, RF11 1: RFO2, RF12			Chooses which output driver and which input will be used in case of single driving.
5	i2c_thd1	0	I2C t_{HD} : non hs-modes / hs-modes 00: 380 ns / 160 ns 01: 180 ns / 160 ns			-
4	i2c_thd0	0	10: 180 ns / 70 ns 11: 100 ns / 70 ns			-
3	RFU	0	-			-
2	out_cl1	0	out_cl1	out_cl0	MCU_CLK	Selection of clock frequency on MCU_CLK output in case Xtal oscillator is running. With "11" MCU_CLK output is permanently low.
			0	0	3.39 MHz	
1	out_cl0	0	0	1	6.78 MHz	
			1	0	13.56 MHz	
0	lf_clk_off	0	1	1	Disabled	
			0: LF clock on MCU_CLK 1: No LF clock on MCU_CLK			By default the 32 kHz LF clock is present on MCU_CLK output when Xtal oscillator is not running and the MCU_CLK output is not disabled.

4.5.2 IO configuration register 2

Register space: A

Address: 01h

Type: RW

Table 21. IO configuration register 2

Bit	Name	Default	Function	Comments
7	sup3V	0	0: 5 V supply 1: 3.3 V supply	Set to 0 for $3.6\text{ V} < V_{DD} \leq 5.5\text{ V}$ Set to 1 for $2.4\text{ V} \leq V_{DD} \leq 3.6\text{ V}$
6	vspd_off	0	0: Enable V_{DD_D} regulator 1: Disable V_{DD_D} regulator	Used for low cost applications. When this bit is set: – at 3 V or 5 V supply V_{DD_D} and V_{DD_A} must be shorted externally
5	aat_en	0	0: Disable AAT D/A 1: Enable AAT D/A	The AAT D/A converters are enabled if both aat_en and en are set. If only aat_en is set and en is cleared, then the AAT outputs are set to a fixed value. Note that for the fixed value to operate, en must have been set to 1 at least once, prior to having en = 0.
4	miso_pd2	0	1: Pull-down on MISO, when BSS is low and MISO is not driven by the ST25R39xxB.	Valid only in SPI mode.
3	miso_pd1	0	1: Pull-down on MISO when BSS is high	
2	io_drv_lvl	0	0: Normal IO driver level 1: Increase IO driving level	Increases IO driver strength of MISO, MCU_CLK an IRQ. Recommended to set to 1 for all I2C operation, and for SPI operation if $V_{DD_IO} < 3.3\text{ V}$.
1	am_ref_rf	0	0: V_{DD_AM} regulator reference from V_{DD_DR} 1: V_{DD_AM} regulator reference from V_{DD_RF}	Selects non modulated RF voltage level reference of the V_{DD_AM} voltage regulator.
0	act_amsink	0	0: active sink disabled 1: active sink enabled	Set to 1 when regulator based AM modulation is enabled (dis_reg_am = 0) and big capacitor is connected to V_{DD_AM} (2.2 uF)

4.5.3 Operation control register

Address: 02h

Type: RW

Table 22. Operation control register⁽¹⁾

Bit	Name	Default	Function	Comments
7	en	0	1: Enables oscillator and regulator (Ready mode)	-
6	rx_en	0	1: Enables Rx operation	-
5	rx_chn	0	0: Both, AM and PM, channels enabled 1: One channel enabled	If only one Rx channel is enabled, selection is done by the Receiver configuration register 1 bit ch_sel.
4	rx_man	0	0: Automatic channel selection 1: Manual channel selection	If both Rx channels are enabled, chooses the method of channel selection, manual selection is done by the Receiver configuration register 1 bit ch_sel.
3	tx_en	0	1: Enables Tx operation	This bit is automatically set by NFC Field ON commands and reset in NFC active communication modes after transmission is finished.
2	wu	0	1: Enables Wake-up mode	According to settings in Wake-up timer control register .
1	en_fd_c1	0	00: External field detector off. 01: Manually enable external field detector with collision avoidance detection threshold.	01: External field detector with collision avoidance detection must be used in R/W mode when using NFC field on commands.
0	en_fd_c0	0	10: Manually enable external field detector with peer detection threshold. 11: Enable external field detector automatically.	11: External field detector with peer detection/collision avoidance threshold activated automatically must be used in NFCIP-1 active communication (AP2P) and Passive target modes. en_fd_c<1:0> ≠ 0 and other bits in Operation control register set to 0 put the device in Low power initial NFC mode.

1. Default setting takes place at power-up only.

4.5.4 Mode definition register

Register space: A

Address: 03h

Type: RW

Table 23. Mode definition register⁽¹⁾

Bit	Name	Default	Function	Comments
7	targ	0	0: Initiator 1: Target	-
6	om3	0	Refer to Table 24 and Table 25	Selection of operation mode. Different for initiator and target modes.
5	om2	0		
4	om1	0		
3	om0	1		
2	tr_am	0	0: OOK 1: AM	Selects RF modulation mode.
1	nfc_ar1	0	00: Off 01: Automatic field on after any reception (including errors) 10: Always after peer field-off 11: RFU	Automatically starts the Response RF collision avoidance ⁽²⁾ .
0	nfc_ar0	0		

1. Register can be written only in case crystal clock is present and stable (oscok = 1).
2. Refer to the note in [Section 4.4.5: NFC field ON commands](#) for handling these bits.

Table 24. Initiator operation modes⁽¹⁾

om3	om2	om1	om0	Comments
0	0	0	0	NFCIP-1 active communication
0	0	0	1	ISO14443A
0	0	1	0	ISO14443B
0	0	1	1	FeliCa™
0	1	0	0	NFC Forum Type 1 tag (Topaz)
1	1	1	0	Sub-carrier stream mode
1	1	1	1	BPSK stream mode
Other combinations				RFU

1. If a non supported operation mode is selected the Tx/Rx operation is disabled.

Table 25. Target operation modes⁽¹⁾⁽²⁾

om3	om2	om1	om0	Comments
0	0	0	1	ISO14443A passive target mode
0	1	0	0	FeliCa™ passive target mode

Table 25. Target operation modes⁽¹⁾⁽²⁾ (continued)

om3	om2	om1	om0	Comments
0	1	1	1	NFCIP-1 active communication mode
1	x	x	x	Bit rate detection mode – om2: enable FeliCa™ bit rate detection mode – om1: RFU – om0: enable ISO14443A bit rate detection mode
Other combinations				Not allowed

1. The nfc_f0 = 1 must not be set in Bit rate detection mode (see [Table 27](#)).
2. When in Passive target and Bit rate detection modes, the pt_res setting is used to generate the RF field (high ohmic setting of pt_res can prevent RF field generation).

4.5.5 Bit rate definition register

Register space: A

Address: 04h

Type: RW

Table 26. Bit rate definition register

Bit	Name	Default	Function	Comments
7	RFU	0	Refer to Table 27	-
6	RFU	0		-
5	tx_rate1	0		Selects bit rate for Tx.
4	tx_rate0	0		
3	RFU	0		-
2	RFU	0		-
1	rx_rate1	0		Selects bit rate for Rx.
0	rx_rate0	0		

Table 27. Bit rate coding⁽¹⁾

rate3	rate2	rate1	rate0	Bit rate (kbit/s)	Comments
0	0	0	0	fc/128 (~106)	-
0	0	0	1	fc/64 (~212)	-
0	0	1	0	fc/32 (~424)	-
0	0	1	1	fc/16 (~848)	-
Other combinations				-	Not used

1. If a non supported bit rate is selected the Tx/Rx operation is disabled.

4.5.6 ISO14443A and NFC 106kb/s settings register

Register space: A

Address: 05h

Type: RW

Table 28. ISO14443A and NFC 106kb/s settings register

Bit	Name	Default	Function	Comments
7	no_tx_par	0	1: No parity bit is generated during Tx	Data stream is taken from FIFO, transmit to be done using command Transmit Without CRC ⁽¹⁾ .
6	no_rx_par	0	1: Receive and put in FIFO also the parity bit	When set to 1 received bit stream is put in the FIFO, no parity and CRC detection is done ⁽¹⁾ . Supported only for 106 kbit/s data rate.
5	nfc_f0	0	1: Support of NFCIP-1 Transport Frame format	Adds SB (F0) and LEN bytes during Tx and skip SB (F0) byte during Rx. Must not be set in bit rate detection mode.
4	p_len3	0	Refer to Table 29	Modulation pulse width, defined in number of 13.56 MHz clock periods.
3	p_len2	0		
2	p_len1	0		
1	p_len0	0		
0	antcl	0	0: Standard frame 1: ISO14443 anticollision frame	Must be set to 1 for reception of ISO14443A bit oriented anticollision frames in reader mode. Must be set to 0 for all other frames and modes.

1. Supported in reader modes only, not supported in card emulation modes.

Table 29. Modulation pulse width

p_len3	p_len2	p_len1	p_len0	ISO14443A modulation pulse width in number of 1 / fc for different bit rates				Stream mode (ISO15693) ⁽¹⁾
				fc/128	fc/64	fc/32	fc/16	fc
0	1	1	1	42	-	-	-	-
0	1	1	0	41	24	-	-	-
0	1	0	1	40	23	-	-	-
0	1	0	0	39	22	13	-	-
0	0	1	1	38	21	12	8	-
0	0	1	0	37	20	11	7	-
0	0	0	1	36	19	10	6	-
0	0	0	0	35	18	9	5	128
1	1	1	1	34	17	8	4	120
1	1	1	0	33	16	7	3	112

Table 29. Modulation pulse width (continued)

p_len3	p_len2	p_len1	p_len0	ISO14443A modulation pulse width in number of 1 / fc for different bit rates				Stream mode (ISO15693) (1)
				fc/128	fc/64	fc/32	fc/16	fc
1	1	0	1	32	15	6	2	104
1	1	0	0	31	14	5	-	96
1	0	1	1	30	13	-	-	88
1	0	1	0	29	12	-	-	80
1	0	0	1	28	-	-	-	-
1	0	0	0	27	-	-	-	-

1. It applies for stx=0 and om=14 only.

4.5.7 ISO14443B settings register 1

Register space: A

Address: 06h

Type: RW

Table 30. ISO14443B settings register 1

Bit	Name	Default	Function				Comments
7	egt2	0	egt2	egt1	egt0	Number of etu	EGT defined in number of etu
			0	0	0	0	
6	egt1	0	0	0	1	1	
			⋮	⋮	⋮	⋮	
5	egt0	0	1	1	0	6	
			1	1	1	7	
4	sof_0	0	0: 10 etu 1: 11 etu				SOF, number of etu with logic 0
3	sof_1	0	0: 2 etu 1: 3 etu				SOF, number of etu with logic 1
2	eof	0	0: 10 etu 1: 11 etu				EOF, number of etu with logic 0
1	half	0	0: SOF and EOF defined by sof_0, sof_1, and eof bit 1: SOF 10.5 etu logic 0, 2.5 etu logic 1, EOF: 10.5 etu logic 0				Sets SOF and EOF settings in middle of specification.
0	RFU	-	-				-

4.5.8 ISO14443B and FeliCa settings register

Register space: A

Address: 07h

Type: RW

Table 31. ISO14443B and FeliCa settings register

Bit	Name	Default	Function	Comments
7	tr1_1	0	Refer to Table 32	-
6	tr1_0	0		
5	no_sof	0	1: No SOF PICC to PCD	Supports PCD capability for suppression of SOF from PICC to PCD according to ISO14443
4	no_eof	0	1: No EOF PICC to PCD	Supports PCD capability for suppression of EOF from PICC to PCD according to ISO14443
3	RFU	0	-	-
2	RFU	0	-	-
1	f_p1	0	00: 48 01: 64	FeliCa™ preamble length (valid also for NFCIP-1 active communication bit rates 212 and 424 kb/s)
0	f_p0	0	10: 80 11: 96	

Table 32. Minimum TR1 codings

tr1_1	tr1_0	Minimum TR1 for a PICC to PCD bit rate	
		fc/128	>fc/128
0	0	80 / fs	
0	1	64 / fs	32 / fs
1	0	Not used	
1	1	Not used	

4.5.9 NFCIP-1 passive target definition register

Register space: A

Address: 08h

Type: RW

Table 33. NFCIP-1 passive target definition register

Bit	Name	Default	Function	Comments
7	fdel3	0	PCD to PICC FDT compensation. Frame compensation defined as $\text{fdel}_{<3:0>*1} / \text{fc}$	Valid for NFC-A CE mode – fdel = 0: Nominal FDT time in produced in logic. – fdel > 0: Shortens the FDT provided by logic. Due to signal processing delays $\text{fdel}_{<3:0> = 2}$ is expected to be a good setting (best value depends also on filter and antenna).
6	fdel2	0		
5	fdel1	0		
4	fdel0	0		
3	d_ac_ap2p	0	0: Enable AP2P frame recognition 1: Disable AP2P frame recognition	-
2	d_212/424_1r	0	0: Enable automatic SENSF_RES 1: Disable automatic SENSF_RES	Disables the automatic responses in passive target mode, and completely operates via FIFO.
1	RFU	0	RFU	
0	d_106_ac_a	0	0: Enable automatic anti-collision in NFC-A 1: Disable automatic anti-collision in NFC-A	

4.5.10 Stream mode definition register

Register space: A

Address: 09h

Type: RW

Table 34. Stream mode definition register

Bit	Name	Default	Function			Comments
7		0	-			-
6	scf1	0	Refer to Table 35			Sub-carrier frequency definition for Sub-carrier stream mode.
5	scf0	0				
4	scp1	0	scp1	scp0	Number of pulses	Number of sub-carrier pulses in report period for Sub-carrier stream mode.
			0	0	RFU	
			0	1	RFU	
3	scp0	0	1	0	4	
			1	1	8	
2	stx2	0	Refer to Table 36			Definition of time period for Tx modulator control (for Sub-carrier and BPSK stream mode).
1	stx1	0				
0	stx0	0				

Table 35. Sub-carrier frequency definition for Sub-Carrier stream mode

scf1	scf0	Sub-Carrier mode	BPSK mode
0	0	-	fc/16 (848 kHz)
0	1	fc/32 (424 kHz)	RFU
1	0	-	
1	1	-	

Table 36. Definition of time period for Stream mode Tx modulator control

stx2	stx1	stx0	Time period
0	0	0	fc/128 (106 kHz)
0	0	1	fc/64 (212 kHz)
0	1	0	fc/32 (424 kHz)
0	1	1	fc/16 (848 kHz)
1	X	X	RFU

4.5.11 Auxiliary definition register

Register space: A

Address: 0Ah

Type: RW

Table 37. Auxiliary definition register

Bit	Name	Default	Function	Comments
7	no_crc_rx	0	0: Receive with CRC check 1: Receive without CRC check	Valid for all protocols, for ISO14443A REQA, WUPA and anticollision receive without CRC is done automatically ⁽¹⁾ .
6	RFU	0	-	-
5	nfc_id1	0	00: 4 bytes NFCID1	Selects NFCID1 size.
4	nfc_id0	0	01: 7 bytes NFCID1 1x: RFU	
3	mfaz_cl90	0	0: 0° shifted clock for phase measurement 1: 90° shifted clock for phase measurement	Affects also PM demodulation. Should be set to 0 for PM demodulation.
2	dis_corr	0	0: Correlation operation 1: RFU	Selects RW receiver operation.
1	nfc_n1	0	-	Value of n for direct commands NFC Initial Field ON and NFC Response Field ON (0...3) ⁽²⁾ .
0	nfc_n0	0		

1. Receive without CRC is done automatically when REQA and WUPA commands are sent using direct commands Transmit REQA and Transmit WUPA, respectively, and in case anticollision is performed setting bit antcl.
2. The value of nfc_n<1:0> must be set prior to the NFC Initial Field ON and NFC Response Field ON operations.

4.5.12 EMD suppression configuration register

Register space: B

Address: 05h

Type: RW

Table 38. EMD suppression configuration register

Bit	Name	Default	Function	Comments
7	emd_emv	0	0: Disable EMD suppression 1: Enable EMD suppression according to EMVCo	Bits no_rx_par and no_crc_rx must be set to 0, and bit nrt_emv must be set to 1 when emd_emv is enabled
6	rx_start_emv	0	0: Reception is enabled (l_rxs) only if the first 4 bits of the frame are error free 1: Reception is enabled (l_rxs) also if there is an error in the first four bits of the frame	Applies to ISO-A 106k only. Must be set to 1 for EMVCo compliance.
5	RFU	0	-	-
4	RFU	0	-	-
3	emd_thld3	0	If the received frame is less than emd_thld<3:0> bytes long then EMD suppression will trigger on reception errors	Must be set to 4 for EMVCo compliance.
2	emd_thld2	0		
1	emd_thld1	0		
0	emd_thld0	0		

4.5.13 Subcarrier start timer register

Register space: B

Address: 06h

Type: RW

Table 39. Subcarrier start timer register

Bit	Name	Default	Function	Comments
7:5	RFU	0	-	-
4:0	sst<4:0>	0	Subcarrier start time Step: 0.25 etu Range: 0 etu to 7.75 etu	Applies to ISO-B, 106 kb/s. If the time from the end of the MRT timer to the detection of a subcarrier is shorter than sst<4:0>, then a soft error interrupt is generated. If emd_emv = 1 the frame will be suppressed as EMD and a restart interrupt will be generated. Note that corr_s3 defines the length of subcarrier start detection and affects the correct sst<4:0> setting.

4.5.14 Receiver configuration register 1

Register space: A

Address: 0Bh

Type: RW

Table 40. Receiver configuration register 1

Bit	Name	Default	Function	Comments
7	ch_sel	0	0: Enable AM channel 1: Enable PM channel	If only one Rx channel is enabled in the Operation control register defines which channel is enabled. If both channels are enabled and manual channel selection is active defines which channel is used for receive framing.
6	lp2	0	Low-pass control (see Table 5)	-
5	lp1	0		
4	lp0	0		
3	z600k	0	First and third stage zero setting (see Table 6)	
2	h200	0		
1	h80	0		
0	z12k	0		

4.5.15 Receiver configuration register 2

Register space: A

Address: 0Ch

Type: RW

Table 41. Receiver configuration register 2

Bit	Name	Default	Function	Comments
7	demod_mode	0	0: AM/PM demodulation 1: I/Q demodulation	Selects demodulator operation mode. I/Q demodulation requires amd_sel = 1.
6	amd_sel	0	0: peak detector 1: mixer	Selects AM demodulator.
5	sqm_dyn	1	0: Squelch disabled 1: Automatic squelch activation after end of TX	Squelch is activated 18.88 μ s after end of TX, and stops when the Mask receive timer reaches the sqt<7:0> setting.
4	pulz_61	0	0: Squelch ratio 1 1: Squelch ratio 6/3	Select squelch trigger level. Squelch triggers on signals that are 1 or 6/3 times larger than the digitizing threshold. – Ratio 1: recommended for ISO-A 106k correlator, ISO-A HBR/ISO-B pulse decoder, ISO-15693, and FeliCa™ – Ratio 6/3: recommended for ISO-A HBR/ISO-B correlator
3	agc_en	1	0: AGC disabled 1: AGC enabled	-
2	agc_m	1	0: AGC operates on first eight sub-carrier pulses 1: AGC operates during complete receive period	-
1	agc_alg	0	0: Algorithm with preset is used 1: Algorithm with reset is used	Algorithm with preset is recommended for protocols with short SOF (like ISO14443A fc / 128).
0	agc6_3	1	0: AGC ratio 3 1: AGC ratio 6	Select AGC trigger level. AGC triggers on signals 3 or 6 times above the minimum detectable signal level.

4.5.16 Receiver configuration register 3

Register space: A

Address: 0Dh

Type: RW

Table 42. Receiver configuration register 3

Bit	Name	Default	Function	Comments
7	rg1_am2	1	Gain reduction/boost in first gain stage of AM channel.	0: Full gain 1-6: Gain reduction 2.5 dB per step (15 dB total) 7: Boost + 5.5 dB
6	rg1_am1	1		
5	rg1_am0	0		
4	rg1_pm2	1	Gain reduction/boost in first gain stage of PM channel.	0: Full gain 1-6: Gain reduction 2.5 dB per step (15 dB total) 7: Boost + 5.5 dB
3	rg1_pm1	1		
2	rg1_pm0	0		
1	lf_en	0	0: HF signal on receiver input 1: LF signal on receiver input	-
0	lf_op	0	0: differential LF operation 1: LF input split (RFI1 to AM channel, RFI2 to PM channel)	-

4.5.17 Receiver configuration register 4

Register space: A

Address: 0Eh

Type: RW

Table 43. Receiver configuration register 4⁽¹⁾

Bit	Name	Default	Function	Comments
7	rg2_am3	0	AM channel: gain reduction in second and third stage and digitizer	Only values from 0h to Ah are used: – settings 1h to 4h reduce gain by increasing the digitizer window in 3 dB steps – values from 5h to Ah additionally reduce the gain in second and third gain stage, always in 3 dB steps.
6	rg2_am2	0		
5	rg2_am1	0		
4	rg2_am0	0		
3	rg2_pm3	0	PM channel: gain reduction in second and third stage and digitizer	Only values from 0h to Ah are used: – settings 1h to 4h reduce gain by increasing the digitizer window in 3 dB steps – values from 5h to Ah additionally reduce the gain in second and third gain stage, always in 3 dB steps.
2	rg2_pm2	0		
1	rg2_pm1	0		
0	rg2_pm0	0		

1. Direct command [Reset RX gain](#) is necessary to load the value of this register into AGC, Squelch, and RSSI block.

4.5.18 P2P receiver configuration register 1

Register space: B

Address: 0Bh

Type: RW

Table 44. P2P receiver configuration register 1

Bit	Name	Default	Function	Comments
7	ook_fd	0	OOK fast decay	-
6	ook_rc1	0	00 = 1.4 μ s 01 = 1.0 μ s	OOK RC time constant
5	ook_rc0	0	10 = 0.6 μ s 11 = 0.2 μ s	
4	ook_thd1	0	Refer to Table 45	OOK threshold level, depends on ook_rc<1:0> configuration.
3	ook_thd0	1		
2	ask_rc1	1	00 = 8.4 μ s 01 = 6.8 μ s	ASK RC time constant
1	ask_rc0	0	10 = 4.4 μ s 11 = 2.4 μ s	
0	ask_thd	0	0: 97% 1: 95%	ASK threshold level

Table 45. OOK threshold level settings

ook_thd<1:0>	ook_rc<1:0> = 0	ook_rc<1:0> > 0
00	55%	80%
01	45%	75%
10	35%	70%
11	25%	65%

4.5.19 Correlator configuration register 1

Register space: B

Address: 0Ch

Type: RW

Table 46. Correlator configuration register 1

Bit	Name	Default	Function		Comments
7	corr_s7	1	AGC = max AM, PM		1: Links the two AGC systems so that the gain in the AM(I) and PM(Q) channels are equal. To be used in summation mode. 0: The AM(I) and PM(Q) AGC channels are independent. To be used in non-summation mode.
6	corr_s6	0	ISO-A 106k	0: Collision detection level defined by corr_s<1:0> 1: Collision detection level equal to data slicer level	Selecting the collision detection level with corr_s<1:0> gives better detection of weak collisions. Setting the collision detection level equal to the data slicer gives better noise immunity.
			BPSK (1)	0: Correlator phase correction applied during the complete reception 1: No correlator phase correction after the first data bytes	No phase correction after start recommended for ISO-B 424 kb/s and 848 kb/s operation.
5	corr_s5	0	0: V _{ref} -50 mV setting, 1 st squelch step -100 mV 1: V _{ref} -100 mV setting, 1 st squelch step -200 mV		-
4	corr_s4	1	0: AM and PM correlation signals digitized separately 1: AM and PM correlation signals summed before digitizing (summation mode)		Summation mode is recommended for all correlator operations
3	corr_s3	0	0: RX bit rate 106kb/s = 17, RX bit rates 212 to 848 kb/s = 9 1: RX bit rate 106kb/s = 33, RX bit rates 212 to 848 kb/s = 17		BPSK start length setting (delay from the start of a tags subcarrier signal to the moment when a subcarrier start is detected). Then circuit starts observing for the first phase transition (9/17/33 ± 2 pilot pulses). At this moment the sst<4:0> check for TR0 is done.
2	corr_s2	0	ISO-A 106k	0: Normal data slicer 1: Fast data slicer	-
			BPSK (1)	0: Normal ref. time constant 1: Long ref. time const. (1.5x normal)	

Table 46. Correlator configuration register 1 (continued)

Bit	Name	Default	Function		Comments
1	corr_s1	1	ISO-A 106k	Collision level setting MSB	Collision detection level, compared to data detection level: – 00: 16% – 01: 28% – 10: 41% – 11: 53%
			BPSK (1)	Subcarrier end detection level 0: 100% 1: 66%	
0	corr_s0	1	ISO-A 106k	Collision level setting LSB	
			BPSK (1)	0: Subcarrier end detector disabled 1: Subcarrier end detector enabled	

1. BPSK options apply to ISO-A HBR and ISO-B (all bit rates).

4.5.20 Correlator configuration register 2

Register space: B

Address: 0Dh

Type: RW

Table 47. Correlator configuration register 2

Bit	Name	Default	Function	Comments
7	RFU	0		
6	RFU	0		
5	RFU	0		
4	RFU	0		
3	RFU	0		
2	RFU	0		
1	corr_s9	0	0: Sleep mode disable set by timer 1: Sleep mode disable only on rx_on = 1	Correlator sleep mode option. Sleep start: 18 µs no output pulse. Stop with timer: – takes 18 µs (ISO-A/B, F424) – takes 42 µs (stream 15693, F212)
0	corr_s8	0	0: All other standards 1: 424 kHz subcarrier stream mode	Must be set to 1 for 424 kHz subcarrier stream mode.

4.5.21 Mask receive timer register

Register space: A

Address: 0Fh

Type: RW

Table 48. Mask receive timer register

Bit	Name	Default	Function	Comments
7	mrt7	0	mrt_step = 0: Step: 64 / fc (4.72 μ s) Range: 256 / fc (~18.88 μ s) to 16320 / fc (~1.2 ms) mrt_step = 1: Step: 512 / fc (37.78 μ s) Range: 2048 / fc (151 μ s) to 130560 / fc (9.62 ms)	Set time after end of TX during which the receiver output is ignored (masked). The minimum mask receive time of 18.88 μ s covers the transients in receiver after end of transmission.
6	mrt6	0		
5	mrt5	0		
4	mrt4	0		
3	mrt3	1		
2	mrt2	1		
1	mrt1	0		
0	mrt0	0		

4.5.22 No-response timer register 1

Register space: A

Address: 10h

Type: RW

Table 49. No-response timer register 1

Bit	Name	Default	Function	Comments
7	nrt15	0	No-response timer definition MSB bits nrt_step = 0: Step: 64 / fc (4.72 μs), Range: 309 ms nrt_step = 1: Step: 4096 / fc (302 μs) Range: 19.8 s.	Defines timeout after end of Tx. If this timeout expires without detecting a response a No-response interrupt is sent. In NFC mode the No-response timer is started only when external field is detected. In the NFCIP-1 active communication mode the No-response timer is automatically started when the transmitter is turned off after the message has been sent. All 0: No-response timer is not started. No-response timer is reset and restarted with Start No-response timer direct command.
6	nrt14	0		
5	nrt13	0		
4	nrt12	0		
3	nrt11	0		
2	nrt10	0		
1	nrt9	0		
0	nrt8	0		

4.5.23 No-response timer register 2

Register space: A

Address: 11h

Type: RW

Table 50. No-response timer register 2

Bit	Name	Default	Function	Comments
7	nrt7	0	No-response timer definition LSB bits	-
6	nrt6	0		
5	nrt5	0		
4	nrt4	0		
3	nrt3	0		
2	nrt2	0		
1	nrt1	0		
0	nrt0	0		

4.5.24 Timer and EMV control register

Register space: A

Address: 12h

Type: RW

Table 51. Timer and EMV control register

Bit	Name	Default	Function	Comments
7	gptc2	0	General purpose timer trigger source. Refer to Table 52	-
6	gptc1	0		
5	gptc0	0		
4	RFU	0	-	-
3	mrt_step	0	0: 64 / fc 1: 512 / fc	Mask receive timer step size
2	nrt_nfc	0	0: NRT starts at end of TX (own field off) 1: NRT starts at peer field-on event	No-response timer start condition in AP2P initiator and target mode.
1	nrt_emv	0	1: No-response timer EMV mode	-
0	nrt_step	0	0: 64 / fc 1: 4096 / fc	No-response timer step size.

Table 52. Trigger sources

gptc2	gptc1	gptc0	Trigger source
X	X	X	The timer starts always with direct command Start General purpose timer.
0	0	0	No additional trigger source.
0	0	1	Additionally starts at End of RX (after EOF).
0	1	0	Additionally starts at Start of RX.
0	1	1	Additionally starts at End of TX. In AP2P modes the timer is used to switch the field off. In AP2P modes enables NRT start according to nrt_nfc description.
1	0	0	RFU
1	0	1	
1	1	0	
1	1	1	

4.5.25 General purpose timer register 1

Register space: A

Address: 13h

Type: RW

Table 53. General purpose timer register 1

Bit	Name	Default	Function	Comments
7	gpt15	0	General purpose timeout definition MSB bits Defined in steps of 8 / fc (590 ns) Range from 590 ns to 38,7 ms	-
6	gpt14	0		
5	gpt13	0		
4	gpt12	0		
3	gpt11	0		
2	gpt10	0		
1	gpt9	0		
0	gpt8	0		

4.5.26 General purpose timer register 2

Register space: A

Address: 14h

Type: RW

Table 54. General purpose timer register 2

Bit	Name	Default	Function	Comments
7	gpt7	0	General purpose timeout definition LSB bits Defined in steps of 8 / fc (590 ns) Range from 590 ns to 38,7 ms	-
6	gpt6	0		
5	gpt5	0		
4	gpt4	0		
3	gpt3	0		
2	gpt2	0		
1	gpt1	0		
0	gpt0	0		

4.5.27 PPON2 field waiting register

Register space: A

Address: 15h

Type: RW

Table 55. PP_{ON2} field waiting register

Bit	Name	Default	Function	Comments
7	ppt7	1	PP _{ON2} timer Step: 64 / fc (4.72 μs) Range: 1.204 ms	Maximum time the system waits for the peer device field on in AP2P mode.
6	ppt6	0		
5	ppt5	0		
4	ppt4	0		
3	ppt3	0		
2	ppt2	0		
1	ppt1	0		
0	ppt0	0		

4.5.28 Squelch timer register

Register space: B

Address: 0Fh

Type: RW

Table 56. Squelch timer register

Bit	Name	Default	Function	Comments
7	sqt7	0	Squelch Timer Step, Range: same as <i>Mask receive timer register</i> , including mrt_step selection	Squelch is enabled ~20 μ s after the end of reader data transmission – sqt<7:0> > 5: Squelch stops after the time defined by sqt<7:0>. Gain reduction due to squelch is locked and used as a starting point for AGC. – Sqt<7:0> \leq 5 or sqt<7:0> \geq mrt<7:0>: Squelch is enabled until the MRT expires.
6	sqt6	0		
5	sqt5	0		
4	sqt4	0		
3	sqt3	0		
2	sqt2	0		
1	sqt1	0		
0	sqt0	0		

4.5.29 NFC field on guard timer register

Register space: B

Address: 15h

Type: RW

Table 57. NFC field on guard timer register

Bit	Name	Default	Function	Comments
7	nfc_gt7	0	NFC field on guard timer Step: 2048 / fc (151 μ s) Range: 38.66 ms	Used by NFC field on commands. The value nfc_gt<7:0> is added to the initial 75 μ s in T _{IRFG} and T _{ARFG} . Set to 33 for T _{IRFG} (75 μ s + 4.984 ms = 5.06 ms) Set to 0 for T _{ARFG} (75 μ s + 0 ms = 75 μ s)
6	nfc_gt6	0		
5	nfc_gt5	1		
4	nfc_gt4	1		
3	nfc_gt3	0		
2	nfc_gt2	0		
1	nfc_gt1	1		
0	nfc_gt0	1		

4.5.30 Mask main interrupt register

Register space: A

Address: 16h

Type: RW

Table 58. Mask main interrupt register

Bit	Name	Default	Function	Comments
7	M_osc	0	1: Mask IRQ when oscillator frequency is stable	-
6	M_wl	0	1: Mask IRQ due to FIFO water level	-
5	M_rxs	0	1: Mask IRQ due to start of receive	-
4	M_rxe	0	1: Mask IRQ due to end of receive	-
3	M_txe	0	1: Mask IRQ due to end of transmission	-
2	M_col	0	1: Mask IRQ due to bit collision	-
1	M_rx_rest	0	1: Mask IRQ due to automatic reception restart	-
0	RFU	0	Not used	-

4.5.31 Mask timer and NFC interrupt register

Register space: A

Address: 17h

Type: RW

Table 59. Mask timer and NFC interrupt register

Bit	Name	Default	Function	Comments
7	M_dct	0	1: Mask IRQ due to termination of direct command	-
6	M_nre	0	1: Mask IRQ due to No-response timer expire	-
5	M_gpe	0	1: Mask IRQ due to general purpose timer expire	-
4	M_eon	0	1: Mask IRQ due to detection of external field higher than Target activation level	-
3	M_eof	0	1: Mask IRQ due to detection of external field drop below Target activation level	-
2	M_cac	0	1: Mask IRQ due to detection of collision during RF Collision Avoidance	-
1	M_cat	0	1: Mask IRQ after minimum guard time expire	-
0	M_nfct	0	1: Mask IRQ when in target mode the initiator bit rate has been recognized	-

4.5.32 Mask error and wake-up interrupt register

Register space: A

Address: 18h

Type: RW

Table 60. Mask error and wake-up interrupt register

Bit	Name	Default	Function	Comments
7	M_crc	0	1: Mask IRQ due to CRC error	-
6	M_par	0	1: Mask IRQ due to parity error	-
5	M_err2	0	1: Mask IRQ due to soft framing error	-
4	M_err1	0	1: Mask IRQ due to hard framing error	-
3	M_wt	0	1: Mask IRQ due to wake-up timer interrupt	-
2	M_wam	0	1: Mask Wake-up IRQ due to amplitude measurement	-
1	M_wph	0	1: Mask Wake-up IRQ due to phase measurement.	-
0	RFU	0	-	-

4.5.33 Mask passive target interrupt register

Register space: A

Address: 19h

Type: RW

Table 61. Mask passive target interrupt register

Bit	Name	Default	Function	Comments
7	M_ppon2	0	1: Mask IRQ from PPON2 field on waiting timer	-
6	M_sl_wl	0	1: Mask IRQ for Passive target slot number water level	-
5	M_apon	0	1: Mask IRQ due to Active PP Field on event	-
4	M_rxe_pta	0	1: Mask IRQ due to end of receive when the device is handling the response	-
3	M_wu_f	0	1: Mask IRQ NFC 212/424 kb/s passive target active	-
2	RFU	0	-	-
1	M_wu_a*	0	1: Mask IRQ NFC 106 kb/s passive target Active*	-
0	M_wu_a	0	1: Mask IRQ NFC 106 kb/s passive target Active	-

4.5.34 Main interrupt register

Register space: A

Address: 1Ah

Type: R

Table 62. Main interrupt register

Bit	Name	Default	Function	Comments
7	I_osc	-	IRQ when oscillator frequency is stable	Set after oscillator is started by setting Operation control register bit en.
6	I_wl	-	IRQ due to FIFO water level	Set during receive, if more than 300 bytes are in the FIFO. Set during transmit, if less than 200 bytes are in the FIFO.
5	I_rxs	-	IRQ due to start of receive	-
4	I_rxe	-	IRQ due to end of receive	-
3	I_txe	-	IRQ due to end of transmission	-
2	I_col	-	IRQ due to bit collision	-
1	I_rx_rest	-	IRQ due to automatic reception restart	Set when a frame is suppressed as EMD
0	RFU	-	-	-

4.5.35 Timer and NFC interrupt register

Register space: A

Address: 1Bh

Type: R

Table 63. Timer and NFC interrupt register⁽¹⁾

Bit	Name	Default	Function	Comments
7	I_dct	-	IRQ due to termination of direct command	-
6	I_nre	-	IRQ due to No-response timer expire	-
5	I_gpe	-	IRQ due to general purpose timer expire	-
4	I_eon	-	IRQ due to detection of external field higher than Target activation level	-
3	I_eof	-	IRQ due to detection of external field drop below Target activation level	-
2	I_cac	-	IRQ due to detection of collision during RF Collision Avoidance	I_cac must be cleared before collision avoidance is performed.
1	I_cat	-	IRQ after minimum guard time expire	An external field was not detected during RF collision avoidance, field was switched on, IRQ sent after minimum guard time according to NFCIP-1.
0	I_nfct	-	IRQ when in target mode the initiator bit rate was recognized	-

1. After register has been read, its content is set to 0.

4.5.36 Error and wake-up interrupt register

Register space: A

Address: 1Ch

Type: R

Table 64. Error and wake-up interrupt register⁽¹⁾

Bit	Name	Default	Function	Comments
7	I_crc	-	CRC error	Avoid delayed reading of interrupt status register to not fall into potential signaling of I_crc.
6	I_par	-	Parity error	-
5	I_err2	-	Soft framing error	Framing error that does not result in corrupted Rx data.
4	I_err1	-	Hard framing error	Framing error that results in corrupted Rx data.
3	I_wt	-	Wake-up timer interrupt	Timeout after execution of Start Wake-Up Timer command in case option with IRQ at every timeout is selected.
2	I_wam	-	Wake-up interrupt due to amplitude measurement	Result of amplitude measurement Δam larger than reference.
1	I_wph	-	Wake-up interrupt due to phase measurement.	Result of phase measurement Δpm larger than reference.
0	RFU	-	-	-

1. After Main Interrupt Register has been read, its content is set to 0.

4.5.37 Passive target interrupt register

Register space: A

Address: 1Dh

Type: R

Table 65. Passive target interrupt register⁽¹⁾

Bit	Name	Default	Function	Comments
7	I_ppon2	-	PPON2 field on waiting timer interrupt	-
6	I_sl_wl	-	IRQ for passive target slot number water level	Sent if four unused slot numbers (TSN) remain in PT_memory.
5	I_apon	-	IRQ due to active P2P field on event	Sent after RF collision avoidance, if there was no collision and field was turned on.
4	I_rxe_pta	-	IRQ due to end of receive, 3916 is handling the response	Sent in passive target mode when NFC-A anti-collision or NFC-F SENSF_RES is automatically sent (MCU action required).
3	I_wu_f	-	NFC 212/424kb/s Passive target 'Active' interrupt	Sent after NFC 212/424 kb/s automatic response to SENSF_REQ was sent.
2	RFU	-	RFU	-
1	I_wu_a*	-	Passive target Active* interrupt	Sent when Active* state is reached.
0	I_wu_a	-	Passive target Active interrupt	Sent when Active state is reached.

1. After register has been read, its content is set to 0.

4.5.38 FIFO status register 1

Register space: A

Address: 1Eh

Type: R

Table 66. FIFO status register 1

Bit	Name	Default	Function	Comments
7	fifo_b7	-	Number of bytes in the FIFO (LSB)	Valid range is from 0 to 512.
6	fifo_b6	-		
5	fifo_b5	-		
4	fifo_b4	-		
3	fifo_b3	-		
2	fifo_b2	-		
1	fifo_b1	-		
0	fifo_b0	-		

4.5.39 FIFO status register 2

Register space: A

Address: 1Fh

Type: R

Table 67. FIFO status register 2

Bit	Name	Default	Function	Comments
7	fifo_b9	-	Number of bytes in the FIFO (MSB)	-
6	fifo_b8	-		-
5	fifo_unf	-	1: FIFO underflow	-
4	fifo_ovr	-	1: FIFO overflow	-
3	fifo_lb2	-	Number of bits in the last FIFO byte if it was not complete	The received bits are stored in the LSB part of the last byte in the FIFO. If I_err1 is set then fifo_lb<2:0> dos not contain valid data.
2	fifo_lb1	-		
1	fifo_lb0	-		
0	np_lb	-	1: Parity bit is missing in the last byte	The bit is set if the last received byte is complete with 8 data bits but he parity bit is missing. If I_err1 is set then np_lb does not contain valid data.

4.5.40 Collision display register

Register space: A

Address: 20h

Type: R

Table 68. Collision display register

Bit	Name	Default	Function	Comments
7	c_byte3	-	Number of full bytes before the bit collision happened.	The <i>Collision display register</i> range covers ISO14443A anticollision command. If collision (or framing error interpreted as collision) happens in a longer message, the <i>Collision display register</i> is not set.
6	c_byte2	-		
5	c_byte1	-		
4	c_byte0	-		
3	c_bit2	-	Number of bits before the collision in the byte where the collision happened	If l_err1 is set then c_byte<3:0> and c_bit<2:0> do not contain valid data.
2	c_bit1	-		
1	c_bit0	-		
0	c_pb	-	1: Collision in parity bit 0: no collision	This error is reported if the first detected collision is in a parity bit. If l_err1 is set then c_pb does not contain valid data.

4.5.41 Passive target display register

Register space: A

Address: 21h

Type: R

Table 69. Passive target display register

Bit	Name	Default	Function	Comments
7	RFU	-	-	-
6	RFU	-	-	-
5	RFU	-	-	-
4	RFU	-	-	-
3	pta_state3	-	0000: POWER OFF 0001: IDLE 0010: READY_L1 0011: READY_L2	ISO-A passive target states. In ACTIVE or ACTIVE* state, the MCU must handle all commands, including SENSE/IDLE and SLEEP/HALT.
2	pta_state2	-	0100: RFU 0101: ACTIVE	
1	pta_state1	-	0110: RFU 1001: HALT 1010: READY_L1* 1011: READY_L2*	
0	pta_state0	-	1100: RFU 1101: ACTIVE*	

4.5.42 Number of transmitted bytes register 1

Register space: A

Address: 22h

Type: RW

Table 70. Number of transmitted bytes register 1

Bit	Name	Default	Function	Comments
7	ntx12	0	Number of full bytes to be transmitted, MSB bits	Maximum supported number of bytes is 8191.
6	ntx11	0		
5	ntx10	0		
4	ntx9	0		
3	ntx8	0		
2	ntx7	0		
1	ntx6	0		
0	ntx5	0		

4.5.43 Number of transmitted bytes register 2

Register space: A

Address: 23h

Type: RW

Table 71. Number of transmitted bytes register 2^{(1) (2)}

Bit	Name	Default	Function	Comments
7	ntx4	0	Number of full bytes to be transmitted, MSB bits	Maximum supported number of bytes is 8191.
6	ntx3	0		
5	ntx2	0		
4	ntx1	0		
3	ntx0	0	Number of bits to transmit after the last full byte. Set to 000 to transmit only full bytes.	Bit transmission starts from LSB. Applicable for ISO14443A: – bit oriented anticollision frame in case last byte is a split byte – Tx is done without parity bit generation
2	nbtx2	0		
1	nbtx1	0		
0	nbtx0	0		

1. If anctl bit is set while card is in idle state and nbtx is not 000, then i_par will be triggered during REQA and WUPA direct command is issued.
2. Transmission of short or incomplete messages only works for ISO-A/B using the command Transmit without CRC.

4.5.44 Bit rate detection display register

Register space: A

Address: 24h

Type: R

Table 72. Bit rate detection display register

Bit	Name	Default	Function	Comments
7	RFU	-	-	-
6	RFU	-	-	-
5	nfc_rate1	-	Refer to Table 27	Result of automatic bit rate detection in the bit rate detection target mode.
4	nfc_rate0	-		
3	ppt2_on	-	1: PP _{ON2} timer is running	State of internal timers.
2	gpt_on	-	1: General purpose timer is running	
1	nrt_on	-	1: No-response timer is running	
0	mrt_on	-	1: Mask receive timer is running	

4.5.45 A/D converter output register

Register space: A

Address: 25h

Type: R

Table 73. A/D converter output register

Bit	Name	Default	Function	Comments
7	ad7	-	Displays the result of the last A/D conversion.	-
6	ad6	-		
5	ad5	-		
4	ad4	-		
3	ad3	-		
2	ad2	-		
1	ad1	-		
0	ad0	-		

4.5.46 Antenna tuning control register 1

Register space: A

Address: 26h

Type: RW

Table 74. Antenna tuning control register 1

Bit	Name	Default	Function	Comments
7	aat_A_7	1	AAT-A D/A converter input.	AAT-A voltage (in V) = $(0.044 + 0.868 * \text{aat_A}<7:0> / 255) * V_{DD_A}$
6	aat_A_6	0		
5	aat_A_5	0		
4	aat_A_4	0		
3	aat_A_3	0		
2	aat_A_2	0		
1	aat_A_1	0		
0	aat_A_0	0		

4.5.47 Antenna tuning control register 2

Register space: A

Address: 27h

Type: RW

Table 75. Antenna tuning control register 2

Bit	Name	Default	Function	Comments
7	aat_B_7	1	AAT-B D/A converter input.	AAT-B voltage (in V) = $(0.044 + 0.868 * \text{aat_B}<7:0> / 255) * V_{DD_A}$
6	aat_B_6	0		
5	aat_B_5	0		
4	aat_B_4	0		
3	aat_B_3	0		
2	aat_B_2	0		
1	aat_B_1	0		
0	aat_B_0	0		

4.5.48 TX driver register

Register space: A

Address: 28h

Type: RW

Table 76. TX driver register

Bit	Name	Default	Function	Comments
7	am_mod3	0	AM modulation index (see Table 77)	-
6	am_mod2	1		
5	am_mod1	1		
4	am_mod0	1		
3	d_res3	0	RFO driver resistance (see Table 78)	-
2	d_res2	0		
1	d_res1	0		
0	d_res0	0		

Table 77. AM modulation index

am_mod<3:0>	Modulation (%)
0	0
1	8
2	10
3	11
4	12
5	13
6	14
7	15
8	20
9	25
10	30
11	40
12	50
13	60
14	70
15	82

Table 78. RFO driver resistance

d_res<3:0>	Driver output resistance (normalized) ⁽¹⁾
0	1.00
1	1.19
2	1.40
3	1.61
4	1.79
5	2.02
6	2.49
7	2.94
8	3.41
9	4.06
10	5.95
11	8.26
12	17.1
13	36.6
14	51.2
15	High Z

1. The value has to be multiplied with the RFO resistance from [Section 5.4: Electrical specifications](#) to obtain the driver output resistance for the corresponding d_res setting.

4.5.49 Auxiliary modulation setting register

Register space: B

Address: 28h

Type: RW

Table 79. Auxiliary modulation setting register

Bit	Name	Default	Function	Comments
7	dis_reg_am	0	0: Regulator AM enabled 1: Regulator AM disabled	Uses am_mod<3:0> to set the modulation index for regulator based AM modulation. Logic of this bit is inverted. Set to 0 to enable regulator AM. 0: To be used with act_amsink=1 and big VDD_AM capacitor (2.2uF) 1: To be used with act_amsink=0 and small VDD_AM capacitor (10-50nF, depending on RF load)
6	lm_ext_pol	0	0: Normal polarity 1: Inverse polarity	Normal polarity: LM_EXT pin load modulation signal is active high. Inverse polarity: LM_EXT pin load modulation signal is active low.
5	lm_ext	0	0: External load modulation disabled 1: External load modulation enabled	Enables output of load modulation signal on LM_EXT pin.
4	lm_dri	1	0: Driver load modulation disabled 1: Driver load modulation enabled	Uses <i>Passive target modulation register</i> to set driver load modulation resistance.
3	res_am	0	0: Resistive AM modulation disabled 1: Resistive AM modulation enabled	Uses md_res<6:0> to configure resistive AM modulated driver resistance.
2	rgs_am	0	1: Regulator shaped AM modulation for AWS enabled 0: Regulator shaped AM modulation for AWS disabled	Set to: 1: When it is used with act_amsink=0 and small VDD_AM capacitor (10-50 nF, depending on RF load) 0: In card mode, wake-up mode and measure amplitude/phase from tx_en=0
1	RFU	0	-	-
0	RFU	0	-	-

4.5.50 Passive target modulation register

Register space: A

Address: 29h

Type: RW

Table 80. Passive target modulation register

Bit	Name	Default	Function	Comments
7	ptm_res3	0	Refer to Table 81	RFO resistance during passive load modulation, modulated state. ptm_res<3:0> must be set before the Mode definition register is set to passive target mode.
6	ptm_res2	1		
5	ptm_res1	1		
4	ptm_res0	0		
3	pt_res3	0		RFO resistance during passive load modulation, unmodulated state. pt_res<3:0> must be set before the Mode definition register is set to passive target mode.
2	pt_res2	0		
1	pt_res1	0		
0	pt_res0	0		

Table 81. Passive target modulated and unmodulated state driver output resistance

ptm_res<3:0> pt_res<3:0>	Driver output resistance R _{RFO} (normalized) ⁽¹⁾
0	1.0
1	2.0
2	4.1
3	8.3
4	12.2
5	17.1
6	25.6
7	32.0
8	36.6
9	42.7
10	51.2
11	64.0
12	85.3
13	128.0
14	256.0
15	High Z

1. The value must be multiplied by the RFO resistance from [Section 5.4: Electrical specifications](#) to obtain the driver output resistance for the corresponding ptm_res/pt_res setting.

4.5.51 TX driver timing register

Register space: B

Address: 29h

Type: RW

Table 82. TX driver timing register

Bit	Name	Default	Function	Comments
7	d_rat_t3	0	Driver transient ratio target (in number of non-overlap times in one RF period)	The value presents the target ratio between one RF period and whole non-overlap time (both sides L to H and H to L). The system starts with the slowest available transient and measures the ratio. If this is lower than targeted the system switches to faster transient. The procedure is repeated until the target ratio is reached (or exceeded for the first time). There are five steps available, procedure can take up to ten RF periods.
6	d_rat_t2	1		
5	d_rat_t1	1		
4	d_rat_t0	1		
3	d_tim_man	1	0: Use automatically acquired timing setting 1: Use manual timing setting	-
2	d_tim_m2	1	000: Slow 001: Medium slow 010: Nominal 011: Medium fast 1xx: Fast	Manual driver timing, used if d_tim_man is set to 1.
1	d_tim_m1	0		
0	d_tim_m0	0		

4.5.52 External field detector activation threshold register

Register space: A

Address: 2Ah

Type: RW

Table 83. External field detector activation threshold register⁽¹⁾

Bit	Name	Default	Function	Comments
7	RFU	0	Not used	-
6	trg_l2	0	Peer detection threshold. Refer to Table 87 .	-
5	trg_l1	1		
4	trg_l0	1		
3	rfe_t3	0	Collision avoidance threshold. Refer to Table 88 .	-
2	rfe_t2	0		
1	rfe_t1	1		
0	rfe_t0	1		

1. The value of rfe_3 must be equal for both activation and deactivation threshold.

4.5.53 Resistive AM modulation register

Register space: B

Address: 2Ah

Type: RW

Table 84. Resistive AM modulation register

Bit	Name	Default	Function	Comments
7	fa3_f	0	0: Use normal non-overlap 1: Use minimum non-overlap	-
6	md_res6	0	Refer to Table 85 .	Resistive AM modulated state driver output resistance.
5	md_res5	0		
4	md_res4	0		
3	md_res3	0		
2	md_res2	0		
1	md_res1	0		
0	md_res0	0		

Table 85. Resistive AM modulated state driver output resistance

md_res<6:0>	Driver output resistance R_{RFO} (normalized) ⁽¹⁾	md_res<6:0>	Driver output resistance R_{RFO} (normalized)
0	1.004	64	4.063
1	1.020	65	4.129
2	1.036	66	4.197
3	1.053	67	4.267
4	1.071	68	4.339
5	1.089	69	4.414
6	1.108	70	4.491
7	1.128	71	4.571
8	1.148	72	4.655
9	1.169	73	4.741
10	1.191	74	4.830
11	1.213	75	4.923
12	1.237	76	5.020
13	1.261	77	5.120
14	1.286	78	5.224
15	1.313	79	5.333
16	1.340	80	5.447

Table 85. Resistive AM modulated state driver output resistance (continued)

md_res<6:0>	Driver output resistance R_{RFO} (normalized) ⁽¹⁾	md_res<6:0>	Driver output resistance R_{RFO} (normalized)
17	1.369	81	5.565
18	1.399	82	5.689
19	1.430	83	5.818
20	1.463	84	5.953
21	1.497	85	6.095
22	1.533	86	6.244
23	1.571	87	6.400
24	1.610	88	6.564
25	1.652	89	6.737
26	1.695	90	6.919
27	1.741	91	7.111
28	1.790	92	7.314
29	1.842	93	7.529
30	1.896	94	7.758
31	1.954	95	8.000
32	2.016	96	8.258
33	2.081	97	8.533
34	2.151	98	8.828
35	2.226	99	9.143
36	2.306	100	9.481
37	2.349	101	9.846
38	2.393	102	10.24
39	2.438	103	10.67
40	2.485	104	11.13
41	2.535	105	11.64
42	2.586	106	12.19
43	2.639	107	12.80
44	2.695	108	13.47
45	2.753	109	14.22
46	2.813	110	15.06
47	2.876	111	16.00
48	2.943	112	17.07
49	3.012	113	18.29
50	3.084	114	19.69

Table 85. Resistive AM modulated state driver output resistance (continued)

md_res<6:0>	Driver output resistance R_{RFO} (normalized) ⁽¹⁾	md_res<6:0>	Driver output resistance R_{RFO} (normalized)
51	3.160	115	21.3
52	3.241	116	23.3
53	3.325	117	25.6
54	3.413	118	28.4
55	3.507	119	32.0
56	3.606	120	36.6
57	3.657	121	42.7
58	3.710	122	51.2
59	3.765	123	64.0
60	3.821	124	85.3
61	3.879	125	128
62	3.938	126	256
63	4.000	127	High Z

1. The value must be multiplied by the RFO resistance from [Section 5.4: Electrical specifications](#) to obtain the driver output resistance for the corresponding md_res setting.

4.5.54 External field detector deactivation threshold register

Register space: A

Address: 2Bh

Type: RW

Table 86. External field detector deactivation threshold register⁽¹⁾

Bit	Name	Default	Function	Comments
7	RFU	0	Not used	-
6	trg_id2	0	Deactivation peer detection threshold (see Table 87).	-
5	trg_id1	1		
4	trg_id0	0		
3	rfe_td3	0	Deactivation collision avoidance threshold (see Table 88).	-
2	rfe_td2	0		
1	rfe_td1	1		
0	rfe_td0	0		

1. The value of rfe_3 must be equal for both activation and deactivation threshold.

Table 87. Peer detection threshold as seen on RF11 input

trg_I2	trg_I1	trg_I0	Peer detection threshold voltage (mV _{pp}) on RF11
0	0	0	75
0	0	1	105
0	1	0	150
0	1	1	205
1	0	0	290
1	0	1	400
1	1	0	560
1	1	1	800

Table 88. Collision avoidance threshold as seen on RF11 input

rfe_3	rfe_2	rfe_1	rfe_0	Collision avoidance threshold voltage (mV _{pp}) on RF11
0	0	0	0	75
0	0	0	1	105
0	0	1	0	150
0	0	1	1	205
0	1	0	0	290
0	1	0	1	400
0	1	1	0	560
0	1	1	1	800
1	0	0	0	25
1	0	0	1	33
1	0	1	0	47
1	0	1	1	64
1	1	0	0	90
1	1	0	1	125
1	1	1	0	175
1	1	1	1	250

4.5.55 TX driver timing display register

Register space: B

Address: 2Bh

Type: R

Table 89. TX driver timing display register

Bit	Name	Default	Function	Comments
7	d_rat_r3	-	Driver Transient ratio readout (in number of non-overlap times in one RF period)	Driver transient ratio readout
6	d_rat_r2	-		
5	d_rat_r1	-		
4	d_rat_r0	-		
3	RFU	-	-	-
2	d_tim_r2	-	000: Slow 001: Medium slow 010: Nominal 011: Medium fast 1xx: Fast	Driver timing readout
1	d_tim_1	-		
0	d_tim_0	-		

4.5.56 Regulator voltage control register

Register space: A

Address: 2Ch

Type: RW

Table 90. Regulator voltage control register

Bit	Name	Default	Function	Comments
7	reg_s	0	0: Regulated voltages are defined by result of Adjust Regulators command 1: Regulated voltages are defined by rege_x bits written in this register	Defines mode of regulator voltage setting.
6	rege_3	0	External definition of regulated voltage (see Table 92). In 5 V mode V_{DD_D} and V_{DD_A} regulators are set to 3.4 V	In 5 V mode V_{DD_D} and V_{DD_A} regulators are set to 3.4 V. In 3.3 V mode V_{DD_D} and V_{DD_A} regulators are set to the same value as V_{DD_RF} .
5	rege_2	0		
4	rege_1	0		
3	rege_0	0		
2	mpsv2	0	000: V_{DD} 001: V_{DD_A} 010: V_{DD_D}	Defines source of direct command Measure power supply .
1	mpsv1	0	011: V_{DD_RF} 100: V_{DD_AM} 101: V_{DD_TX}	
0	mpsv0	0	110: RFU 111: RFU	

4.5.57 Regulator display register

Register space: B

Address: 2Ch

Type: R

Table 91. Regulator display register

Bit	Name	Default	Function	Comments
7	reg_3	-	Voltage regulator setting after <i>Adjust regulators</i> command. Refer to Table 92 for definition.	-
6	reg_2	-		
5	reg_1	-		
4	reg_0	-		
3	RFU	-	-	-
2	RFU	-	-	-
1	RFU	-	-	-
0	i_lim	-	1: V _{DD_RF} regulator in current limit mode	-

Table 92. Regulated voltages

reg_3	reg_2	reg_1	reg_0	Typical regulated voltage (V)	
				5 V mode	3.3 V mode
rege_3	rege_2	rege_1	rege_0		
1	1	1	1	5.1	3.4
1	1	1	0	5.0	3.3
1	1	0	1	4.9	3.2
1	1	0	0	4.8	3.1
1	0	1	1	4.7	3.0
1	0	1	0	4.6	2.9
1	0	0	1	4.5	2.8
1	0	0	0	4.4	2.7
0	1	1	1	4.3	2.6
0	1	1	0	4.2	2.5
0	1	0	1	4.1	2.4
0	1	0	0	4.0	-
0	0	1	1	3.9	-
0	0	1	0	3.8	-
0	0	0	1	3.7	-
0	0	0	0	3.6	-

4.5.58 RSSI display register

Register space: A

Address: 2Dh

Type: R

Table 93. RSSI display register

Bit	Name	Default	Function	Comments
7	rss_i_am_3	-	AM channel RSSI peak value. Refer to Table 94 for definition.	Stores the AM channel RSSI peak value until the start of the next reception, or until the Clear RSSI command is sent.
6	rss_i_am_2	-		
5	rss_i_am_1	-		
4	rss_i_am_0	-		
3	rss_i_pm_3	-	PM channel RSSI peak value. Refer to Table 94 for definition.	Stores the PM channel RSSI peak value until the start of the next reception, or until the Clear RSSI command is sent.
2	rss_i_pm_2	-		
1	rss_i_pm_1	-		
0	rss_i_pm_0	-		

Table 94. RSSI

rss_i_3	rss_i_2	rss_i_1	rss_i_0	Typical signal on RF11 (mV _{rms})
0	0	0	0	≤20
0	0	0	1	>20
0	0	1	0	>27
0	0	1	1	>37
0	1	0	0	>52
0	1	0	1	>72
0	1	1	0	>99
0	1	1	1	>136
1	0	0	0	>190
1	0	0	1	>262
1	0	1	0	>357
1	0	1	1	>500
1	1	0	0	>686
1	1	0	1	>950
1	1	1	0	>1150
1	1	1	1	

4.5.59 Gain reduction state register

Register space: A

Address: 2Eh

Type: R

Table 95. Gain reduction state register

Bit	Name	Default	Function	Comments
7	gs_am_3	-	Refer to rg2_am<3:0> for value explanation.	Overall AM channel second and third stage gain reduction (includes register gain reduction, squelch and AGC).
6	gs_am_2	-		
5	gs_am_1	-		
4	gs_am_0	-		
3	gs_pm_3	-	Refer to rg2_pm<3:0> for value explanation.	Overall PM channel second and third stage gain reduction (includes register gain reduction, squelch and AGC).
2	gs_pm_2	-		
1	gs_pm_1	-		
0	gs_pm_0	-		

4.5.60 AWS Config 1 register^(a)

Register Space: B

Address: 2Eh

Type: RW

Table 96. AWS configuration 1

Bit	Name	Default	Function	Comments
7:4	RFU	-	-	-
3	vddrf_cont	0	1: VDD_RF regulator continuous operation	It must be set to 1
2	RFU	-	-	-
1	vddrf_rx_only	0	0: Use VDD_RF after each modulation gap 1: Use VDD_RF for RX only	0: at the end of each modulation pause, the driver switches to VDD_RF 1: The driver switches to VDD_RF only during RX period. To set vddrf_rx_only to 1 is only allowed when internal LDO is bypassed.
0	rgs_txonoff	0	1: Enables regulator shape for TX field on/off	Must be set to 1 to shape TX field on/off

a. Settings for this register are only applicable when bit rgs_am=1

4.5.61 AWS Config 2 register^(a)

Register Space: B

Address: 2Fh

Type: RW

Table 97. AWS configuration 2

Bit	Name	Default	Function	Comments
7:6	RFU	-	-	-
5	am_sym	0	0: Nonsymmetrical shape 1: Symmetrical shape	For OOK modulation typically different signal fall and rise times are required and a non-symmetrical shape is preferred. For ASK modulation a symmetrical shape during signal fall and rise time is preferred.
4	en_modsink	0	0: weak sink during AWS modulation 1: strong sink during AWS modulation	Selection between strong and weak sink for discharging VDD_AM
3	am_filt3	0	Filter for AM reference in AWS	Sets the time constant of the first order filter for the AM reference A higher am_filt value increases the signal rise and fall time in combination with AWS time register settings
2	am_filt2	0		
1	am_filt1	0		
0	am_filt0	0		

a. Settings for this register are only applicable when bit rgs_am=1.

4.5.62 Auxiliary display register

Register space: A

Address: 31h

Type: R

Table 98. Auxiliary display register

Bit	Name	Default	Function	Comments
7	a_cha	-	0: AM 1: PM	Receiver channel used in ongoing/last reception.
6	efd_o	-	1: External field detected	External field detector output.
5	tx_on	-	1: Transmission is active	Data transmission due to automatic handling of CE mode collision avoidance are not indicated.
4	osc_ok	-	1: Xtal oscillation is stable	Indication that Xtal oscillator is active and its output is stable.
3	rx_on	-	1: Receive decoder is enabled	-
2	rx_act	-	1: Receive decoder is receiving a message	-
1	en_peer	-	1: External field detector is active in Peer detection mode	-
0	en_ac	-	1: External field detector is active in RF collision avoidance mode	-

4.5.63 Overshoot protection configuration register 1

Register space: B

Address: 30h

Type: RW

Table 99. Overshoot protection configuration register 1

Bit	Name	Default	Function	Comments
7	ov_tx_mode1	0	00: Drive with V _{DD_DR} 01: Drive with V _{DD_AM}	Selects RF drive level to apply when ov_patternX is set to 1. ov_tx_mode <1:0> is only effective when bit rgs_am=0
6	ov_tx_mode0	0	10: Driver stop (at GND / V _{DD_DR}) 11: RFU	
5	ov_pattern13	0	Applicable for all ov_pattern cells: Pulse drive in modulation period	Applicable for all ov_pattern cells: rgs_am=0: – Drive level as defined in ov_tx_mode is applied rgs_am=1: – 0: Drive with V _{DD_DR} – 1: Drive with V _{DD_AM}
4	ov_pattern12	0	-	-
3	ov_pattern11	0	-	-
2	ov_pattern10	0	-	-
1	ov_pattern9	0	-	-
0	ov_pattern8	0	-	-

4.5.64 Overshoot protection configuration register 2

Register space: B

Address: 31h

Type: RW

Table 100. Overshoot protection configuration register 2

Bit	Name	Default	Function	Comments
7	ov_pattern7	0	Applicable for all ov_pattern cells: Pulse drive in modulation period	Applicable for all ov_pattern cells: rgs_am=0: – Drive level as defined in ov_tx_mode is applied rgs_am=1: – 0: Drive with V _{DD_DR} – 1: Drive with V _{DD_AM}
6	ov_pattern6	0	-	-
5	ov_pattern5	0	-	-

Table 100. Overshoot protection configuration register 2 (continued)

Bit	Name	Default	Function	Comments
4	ov_pattern4	0	-	-
3	ov_pattern3	0	-	-
2	ov_pattern2	0	-	-
1	ov_pattern1	0	-	-
0	ov_pattern0	0	-	-

4.5.65 Undershoot protection configuration register 1

Register space: B

Address: 32h

Type: RW

Table 101. Undershoot protection configuration register 1

Bit	Name	Default	Function	Comments
7	un_tx_mode1	0	00: Drive with V_{DD_DR} 01: Drive with V_{DD_AM}	Selects RF drive level to apply when un_patternX is set to 1. un_tx_mode <1:0> is only effective when bit rgs_am=0
6	un_tx_mode0	0	10: Driver stop (at GND / V_{DD_DR}) 11: RFU	
5	un_pattern13	0	Applicable for all un_pattern cells: Pulse drive after modulation period	Applicable for all un_pattern cells: rgs_am=0: – Drive level as defined in un_tx_mode is applied rgs_am=1: – 0: Drive with V_{DD_DR} – 1: Drive with V_{DD_AM}
4	un_pattern12	0	-	-
3	un_pattern11	0	-	-
2	un_pattern10	0	-	-
1	un_pattern9	0	-	-
0	un_pattern8	0	-	-

4.5.66 Undershoot protection configuration register 2

Register space: B

Address: 33h

Type: RW

Table 102. Undershoot protection configuration register 2

Bit	Name	Default	Function	Comments
7	un_pattern7	0	Applicable for all un_pattern cells: Pulse drive after modulation period	Applicable for all un_pattern cells: rgs_am=0: – Drive level as defined in un_tx_mode is applied rgs_am=1: – 0: Drive with VDD_DR – 1: Drive with VDD_AM
6	un_pattern6	0	-	-
5	un_pattern5	0	-	-
4	un_pattern4	0	-	-
3	un_pattern3	0	-	-
2	un_pattern2	0	-	-
1	un_pattern1	0	-	-
0	un_pattern0	0	-	-

4.5.67 Wake-up timer control register

Register space: A

Address: 32h

Type: RW

Table 103. Wake-up timer control register

Bit	Name	Default	Function	Comments
7	wur	0	0: 100 ms 1: 10 ms	Wake-up timer range
6	wut2	0	Refer to Table 104	Wake-up timer timeout value
5	wut1	0		
4	wut0	0		
3	wto	0	1: IRQ at every timeout	-
2	wam	0	1: At timeout perform amplitude measurement	Generates I_wam interrupt if amplitude difference is larger than Δam .
1	wph	0	1: At timeout perform phase measurement	Generates I_wph interrupt if phase difference is larger than Δpm .
0	RFU	0	-	-

Table 104. Typical wake-up time

wut2	wut1	wut0	100 ms range (wur = 0)	10 ms range (wur = 1)
0	0	0	100 ms	10 ms
0	0	1	200 ms	20 ms
0	1	0	300 ms	30 ms
0	1	1	400 ms	40 ms
1	0	0	500 ms	50 ms
1	0	1	600 ms	60 ms
1	1	0	700 ms	70 ms
1	1	1	800 ms	80 ms

4.5.68 Amplitude measurement configuration register

Register space: A

Address: 33h

Type: RW

Table 105. Amplitude measurement configuration register

Bit	Name	Default	Function	Comments
7	am_d3	0	Definition of Δam (difference vs. reference that triggers interrupt)	-
6	am_d2	0		
5	am_d1	0		
4	am_d0	0		
3	am_aam	0	0: Exclude the IRQ measurement 1: Include the IRQ measurement	Includes/excludes the measurement that causes IRQ (having difference > Δam to reference) in auto-averaging.
2	am_aew1	0	00: 4 01: 8	Weight of last measurement result for auto-averaging.
1	am_aew2	0	10: 16 11: 32	
0	am_ae	0	0: Use <i>Amplitude measurement reference register</i>	Selects reference value for amplitude measurement Wake-up mode.

4.5.69 Amplitude measurement reference register

Register space: A

Address: 34h

Type: RW

Table 106. Amplitude measurement reference register

Bit	Name	Default	Function	Comments
7	am_ref7	0	-	-
6	am_ref6	0	-	-
5	am_ref5	0	-	-
4	am_ref4	0	-	-
3	am_ref3	0	-	-
2	am_ref2	0	-	-
1	am_ref1	0	-	-
0	am_ref0	0	-	-

4.5.70 AWS time 1 register

Register Space: B

Address: 34h

Type: RW

Table 107. AWS time 1 register

Bit	Name	Default	Function	Comments
7	RFU	0	-	It must be set to 0 for bit 4 to 7
6	RFU	0	-	-
5	RFU	0	-	-
4	RFU	0	-	-
3	tmodsw1_3	0	time	Set the time in fc periods when clamp between VDD_RF and VDD_AM is released.
2	tmodsw1_2	0		
1	tmodsw1_1	0		
0	tmodsw1_0	0		

4.5.71 AWS time 2 register

Register Space: B

Address: 35h

Type: RW

Table 108. AWS time 2 register

Bit	Name	Default	Function	Comments
7	tammod1_3	0	time	Sets the time in fc periods when the VDD_AM modulation starts changing and the driver switches to VDD_AM. The value should be smaller or equal to tmodsw1, it is recommended 0
6	tammod1_2	0		
5	tammod1_1	0		
4	tammod1_0	0		
3	tdres1_3	0	time	Set the time in fc periods when the driver resistance changes to modulation resistance. The recommended setting for bits tdres1 is 0 when using AWS.
2	tdres1_2	0		
1	tdres1_1	0		
0	tdres1_0	0		

4.5.72 AWS time 3 register

Register Space: B

Address: 36h

Type: RW

Table 109. AWS time 3 register

Bit	Name	Default	Function	Comments
7	tentx1_3	0	time	Set the time in fc periods when the driver stops driving. The value depends on setting of am_filt.
6	tentx1_2	0		
5	tentx1_1	0		
4	tentx1_0	0		
3	tmods2_3	0		It is the time in fc periods when the driver switches to VDD_RF. The value depends on setting of am_filt.
2	tmods2_2	0		
1	tmods2_1	0		
0	tmods2_0	0		

4.5.73 AWS time 4 register

Register Space: B

Address: 37h

Type: RW

Table 110. AWS time 4 register

Bit	Name	Default	Function	Comments
7	RFU	0	-	It must be set to 0 for bit 4 to 7
6	RFU	0	-	-
5	RFU	0	-	-
4	RFU	0	-	-
3	tmodsw2_3	0	time	Set the time in fc periods when clamp between VDD_RF and VDD_AM is connected. The value depends on am_filt.
2	tmodsw2_2	0		
1	tmodsw2_1	0		
0	tmodsw2_0	0		

4.5.74 AWS time 5 register

Register Space: B

Address: 38h

Type: RW

Table 111. AWS time 5 register

Bit	Name	Default	Function	Comments
7	tdres2_3	0	time	Set the time in fc periods when the driver resistance changes to driving resistance. The recommended setting for bits tdres2 is 0 when using AWS.
6	tdres2_2	0		
5	tdres2_1	0		
4	tdres2_0	0		
3	RFU	0	-	It must be set to 0 for bit 0 to 3.
2	RFU	0	-	-
1	RFU	0	-	-
0	RFU	0	-	-

4.5.75 AWS time 6 register

Register Space: B

Address: 39h

Type: R

Table 112. AWS time 6 register

Bit	Name	Default	Function	Comments
7:3	RFU	0	-	-
2	rc_cal_ro_2	0	RC calibration readout	Center 011b, 8 steps available, the step size is 12 %
1	rc_cal_ro_1	0		
0	rc_cal_ro_0	0		

4.5.76 Amplitude measurement auto-averaging display register

Register space: A

Address: 35h

Type: R

Table 113. Amplitude measurement auto-averaging display register

Bit	Name	Default	Function	Comments
7	amd_aad7	0	-	-
6	amd_aad6	0	-	-
5	amd_aad5	0	-	-
4	amd_aad4	0	-	-
3	amd_aad3	0	-	-
2	amd_aad2	0	-	-
1	amd_aad1	0	-	-
0	amd_aad0	0	-	-

4.5.77 Amplitude measurement display register

Register space: A

Address: 36h

Type: R

Table 114. Amplitude measurement display register

Bit	Name	Default	Function	Comments
7	am_amd7	0	-	-
6	am_amd6	0	-	-
5	am_amd5	0	-	-
4	am_amd4	0	-	-
3	am_amd3	0	-	-
2	am_amd2	0	-	-
1	am_amd1	0	-	-
0	am_amd0	0	-	-

4.5.78 Phase measurement configuration register

Register space: A

Address: 37h

Type: RW

Table 115. Phase measurement configuration register

Bit	Name	Default	Function	Comments
7	pm_d3	0	Definition of Δpm (difference to reference that triggers interrupt)	-
6	pm_d2	0		
5	pm_d1	0		
4	pm_d0	0		
3	pm_aam	0	0: Exclude the IRQ measurement 1: Include the IRQ measurement	Includes/excludes the measurement value that triggered the I_wph interrupt in the auto-averaging.
2	pm_aew1	0	00: 4 01: 8 10: 16 11: 32	Weight of last measurement result for auto-averaging.
1	pm_aew0	0		
0	pm_ae	0	0: Use <i>Phase measurement reference register</i> 1: Use phase measurement auto-averaging as reference	Selects reference value for phase measurement Wake-up mode.

4.5.79 Phase measurement reference register

Register space: A

Address: 38h

Type: RW

Table 116. Phase measurement reference register

Bit	Name	Default	Function	Comments
7	pm_ref7	0	-	-
6	pm_ref6	0	-	-
5	pm_ref5	0	-	-
4	pm_ref4	0	-	-
3	pm_ref3	0	-	-
2	pm_ref2	0	-	-
1	pm_ref1	0	-	-
0	pm_ref0	0	-	-

4.5.80 Phase measurement auto-averaging display register

Register space: A

Address: 39h

Type: R

Table 117. Phase measurement auto-averaging display register

Bit	Name	Default	Function	Comments
7	pm_aad7	0	-	-
6	pm_aad6	0	-	-
5	pm_aad5	0	-	-
4	pm_aad4	0	-	-
3	pm_aad3	0	-	-
2	pm_aad2	0	-	-
1	pm_aad1	0	-	-
0	pm_aad0	0	-	-

4.5.81 Phase measurement display register

Register space: A

Address: 3Ah

Type: R

Table 118. Phase measurement display register

Bit	Name	Default	Function	Comments
7	pm_amd7	0	0	-
6	pm_amd6	0	0	-
5	pm_amd5	0	0	-
4	pm_amd4	0	0	-
3	pm_amd3	0	0	-
2	pm_amd2	0	0	-
1	pm_amd1	0	0	-
0	pm_amd0	0	0	-

4.5.82 Measurement TX delay

Register space: A

Address: 3Bh

Type: RW

Table 119. Measurement TX delay

Bit	Name	Default	Function	Comments
7	m_phase_ana	0	Connects analog phase measurement signal to TAD2 (set tana<3:0>to 07h)	When m_amp_ana = 1 or m_phase_ana = 1, field gets enabled; not to be used during NFC communication: 00: disabled 01: Amplitude measurement signal to TAD2 10: Phase measurement signal to TAD2 11: Amplitude measurement signal to TAD1, The phase measurement signal to TAD2, to be used in Ready mode only.
6	m_amp_ana	0	Connects analog amplitude measurement signal to TAD1/TAD2 (set tana<3:0>to 07h)	
5	RFU	0	-	-
4	RFU	0	-	-
3	meas_tx_del3	0	0: Disabled >0: Delay enable according to Table 120	meas_tx_del<0:3> bits set the time to prolong the time before TX field is enabled and the measure amplitude and/or phase measurement is performed.
2	meas_tx_del2	0		
1	meas_tx_del1	0		
0	meas_tx_del0	0		

Table 120. Wake-up time and wake-up pulse prolongation⁽¹⁾

wur	wut	Wake-up time	meas_tx_del															Unit	
			0	1	2	3	4	5	6	7	8	9	10	11	12	13	14		15
0	0	10 ms	0	0.7	1.3	1.9	2.5	3.1	3.7	4.3	4.9	5.5	6.1	7.3	8.5	9.7	10.9	12.2	ms
0	1	20 ms	0	0.4	1.0	1.6	2.3	2.9	3.5	4.1	4.7	5.3	5.9	7.1	8.3	9.5	10.7	11.9	
0	2	30 ms	0	NA ⁽²⁾	0.8	1.4	2.0	2.6	3.2	3.8	4.4	5.0	5.6	6.8	8.1	9.3	10.5	11.7	
0	3	40 ms	0	NA	0.6	1.2	1.8	2.4	3.0	3.6	4.2	4.8	5.4	6.6	7.8	9.0	10.2	11.4	
0	4	50 ms	0	NA	NA	0.9	1.5	2.1	2.8	3.4	4.0	4.6	5.2	6.4	7.6	8.8	10.0	11.2	
0	5	60 ms	0	NA	NA	0.7	1.3	1.9	2.5	3.1	3.7	4.3	4.9	6.1	7.3	8.6	9.8	11.0	
0	6	70 ms	0	NA	NA	NA	1.1	1.7	2.3	2.9	3.5	4.1	5.0	5.9	7.1	8.3	9.5	10.7	
0	7	80 ms	0	NA	NA	NA	0.8	1.4	3.9	2.6	3.3	3.9	4.5	5.7	6.9	8.1	9.3	10.5	
1	0	100 ms	0	0.9	1.5	2.1	2.7	3.3	3.9	4.5	5.1	5.7	6.3	7.5	8.7	9.9	11.2	12.4	
1	1	200 ms	0	0.9	1.5	2.1	2.7	3.3	3.9	4.5	5.1	5.7	6.3	7.5	8.7	9.9	11.1	12.3	
1	2	300 ms	0	0.8	1.4	2.0	2.7	3.3	3.9	4.5	5.1	5.7	6.3	7.5	8.7	9.9	11.1	12.3	
1	3	400 ms	0	0.8	1.4	2.0	2.6	3.2	3.8	4.4	5.0	5.6	6.3	7.5	8.7	9.9	11.1	12.3	
1	4	500 ms	0	0.8	1.4	2.0	2.6	3.2	3.8	4.4	5.0	5.6	6.2	7.4	8.6	9.9	11.1	12.3	
1	5	600 ms	0	0.8	1.4	2.0	2.6	3.2	3.8	4.4	5.0	5.6	6.2	7.4	8.6	9.8	11.0	12.2	
1	6	700 ms	0	0.8	1.4	2.0	2.6	3.2	3.8	4.4	5.0	5.6	6.2	7.4	8.6	9.8	11.0	12.2	
1	7	800 ms	0	0.7	1.3	1.9	2.5	3.1	3.7	4.3	5.0	5.6	6.2	7.4	8.6	9.8	11.0	12.2	

1. An additional +/- 20% tolerance must be considered for the meas_tx_del values.

2. Not applicable.

4.5.83 IC identity register

Register space: A

Address: 3Fh

Type: R

Table 121. IC identity register

Bit	Name	Default	Function	Comments
7	ic_type4	0	IC type code 00110: ST25R3916B	5-bit IC type code
6	ic_type3	0		
5	ic_type2	1		
4	ic_type1	1		
3	ic_type0	0		
2	ic_rev2	0	IC revision code 001: rev 4.1	3-bit IC revision code
1	ic_rev1	0		
0	ic_rev0	1		

5 Electrical characteristics

5.1 Absolute maximum ratings

Stresses beyond the limits listed in [Table 122](#) may cause permanent damage to the device. These are stress ratings only.

Functional operation of the device at these or any other conditions beyond those indicated in [Table 122](#) is not implied. Exposure to absolute maximum rating conditions for extended periods may affect device reliability.

Table 122. Absolute maximum ratings

Symbol	Parameter	Min	Max	Unit
$V_{DD}, V_{DD_TX}^{(1)}$	Positive supply voltage	-0.3	6.0	V
$V_{DD}, V_{DD_TX}^{(1)(2)}$	Positive supply voltage when option bit sup3V is set	-0.3	5	
$\Delta V_{DD-V_{DD_TX}}^{(1)}$	Difference between V_{DD} and V_{DD_TX}	-0.3	0.3	
$V_{DD_IO}^{(1)}$	Peripheral communication supply voltage	-0.3	6	
$V_{GND}^{(1)}$	Negative supply voltage	-0.3	0.3	
$V_{pIO}^{(1)}$	Voltage for peripheral IO communication pins (27 to 32)	-0.3	6	
$V_{p5V}^{(1)}$	Voltage for other pins (9, 11, 13, 14, 15, 17 and 20) in the 5 V domain	-0.3	6	
$V_{p3V}^{(1)}$	Voltage for other pins (2 to 5, 7, 18, 19 and 22 to 25) in the 3 V domain	-0.3	5	
I_{scr}	Input current (latch-up immunity) according to JESD78	-100	100	mA
I_{VDD_LDO}	Maximum driver current using internal voltage regulator	-	350 ⁽³⁾	mA
$I_{VDD_EXT}^{(4)}$	Peak current supplied from an external source, internal voltage regulator bypassed	-	500 ⁽⁵⁾	
ESD voltage	Electrostatic discharge voltage according to JS-001, human body model	-	2000	V
T_{strg}	Storage temperature	-65	150	°C
T_{body}	Package body temperature according to IPC/JEDEC J-STD-020 ⁽⁶⁾	-	260	
T_{Jun}	Junction temperature	-40	125	
-	Humidity non-condensing	5	85	%

1. Referenced to V_{SS} .
2. Bit sup3V set to 1 in [IO configuration register 2](#).
3. Provide good thermal management to ensure that junction temperature remains below the specified value.
4. V_{DD_RF} is connected to V_{DD_TX} to bypass the internal voltage regulator.
5. Peak current with RF driver externally supplied. Provide good thermal management to ensure that junction temperature remains below the specified value.
6. Reflow peak soldering temperature (body temperature) is specified according to IPC/JEDEC J-STD-020 "Moisture/Reflow Sensitivity Classification for Non-hermetic Solid State Surface Mount Devices".

5.2 Operating conditions

All defined tolerances for external components in this specification need to be ensured over the whole operation conditions range and also over lifetime.

Table 123. Operating conditions

Symbol	Parameter	Min	Max	Unit
$V_{DD}, V_{DD_TX}^{(1) (2)}$	Positive supply voltage (pins 8 and 10), $T_{amb} = -40$ to 105 °C, rege <3:0> $\geq 07h$	2.6	5.5	V
	Positive supply voltage (pins 8 and 10), $T_{amb} = -20$ to 105 °C	2.4	5.5	
	Positive supply voltage when option bit sup3V is set ⁽³⁾ , $T_{amb} = -40$ to 105 °C, rege <3:0> $\geq 07h$	2.6	3.6	
	Positive supply voltage when option bit sup3V is set ⁽³⁾ , $T_{amb} = -20$ to 105 °C	2.4	3.6	
$\Delta V_{DD-V_{DD_TX}}^{(1)}$	Difference between V_{DD} and V_{DD_TX}	-0.2	0.2	V
$V_{DD_IO}^{(1)}$	Peripheral communication supply voltage (pin 1)	1.65	5.5	
$V_{GND}^{(1)}$	Negative supply voltage (pins 6, 12, 16 and 26)	0	0	
$V_{pIO}^{(1)}$	Voltage for peripheral IO communication pins (27 to 32)	0	5.5	
$V_{p5V}^{(1)}$	Voltage for other pins (9, 11, 13, 14, 15, 17, and 20) in the 5 V domain	0	5.5	
$V_{p3V}^{(1)}$	Voltage for other pins (2 to 5, 7, 18, 19 and 22 to 25) in the 3 V domain	0	3.6	
$T_{(amb, VFQFPN32)}^{(4)}$	Ambient temperature range for VFQFPN32 package	-40	105	°C
$T_{(amb, UFQFPN32)}^{(4)}$	Ambient temperature range for UFQFPN32 package	-40	105	°C
$T_{(amb, WLCSP36)}^{(4)}$	Ambient temperature range for WLCSP36 package	-40	85	°C
V_{RFI_A}	RFI input amplitude ⁽⁵⁾	0.15	3	V_{PP}

1. Referenced to V_{SS} .
2. If power supply is lower than 2.6 V, PSSR cannot be improved using internal regulators (minimum regulated voltage is 2.4 V).
3. Bit sup3V set to 1 in [IO configuration register 2](#).
4. The device must be mounted on a PCB with sufficient heat dissipation.
5. The minimum RFI input signal definition is meant for NFC active P2P reception and NFC passive target reception. In HF reader mode and NFC transmit mode recommended signal level is $2.5 V_{PP}$.

5.3 DC/AC characteristics for digital inputs and outputs

Table 124. Characteristics of CMOS I/Os⁽¹⁾

Type	Symbol	Parameter	Conditions	Min	Typ	Max	Unit	
Inputs ⁽²⁾	V _{IH}	High level input voltage	-	0.8 * V _{DD_IO}	-	-	V	
	V _{IL}	Low level input voltage	-	-	-	0.2 * V _{DD_IO}		
	I _{LEAK}	Input leakage current	V _{DD_IO} = 5.5 V	-1	-	1	μA	
Output	V _{OH}	High level output voltage	I _{source} = 1 mA V _{DD_IO} = 3.3 to 5.5 V, io_drv_lvl=0 ⁽³⁾	0.9 * V _{DD_IO}	-	-	V	
			I _{source} = 0.5 mA V _{DD_IO} = 1.65 to 3.3 V ⁽⁴⁾ io_drv_lvl = 1		-	-		
	V _{OL}	Low level output voltage	I _{source} = 1 mA V _{DD_IO} = 3.3 to 5.5 V ⁽³⁾ , io_drv_lvl=0	-	-	0.1 * V _{DD_IO}		
			I _{source} = 0.5 mA V _{DD_IO} = 1.65 to 3.3 V ⁽⁴⁾ io_drv_lvl = 1	-	-	0.1 * V _{DD_IO}		
	C _L	Capacitive load	-	-	-	50		pF
	R _O	Output resistance	V _{DD_IO} = 3.3 V	-	250	500		Ω
R _{PD}	Pull-down resistance pin MISO ⁽⁵⁾	V _{DD_IO} = 3.3 V	-	10	-	kΩ		

1. Min and Max values Tested in production at 25 °C, other temperature values evaluated by characterization.
2. Pins BSS, MOSI and SCLK.
3. Tested in production at 3.3 V at 25 °C, other temperature and V_{DD_IO} values evaluated by characterization.
4. Tested in production at 1.8 V at 25 °C, other temperature and V_{DD_IO} values evaluated by characterization.
5. Use bits miso_pd1 and miso_pd2 in the [IO configuration register 2](#) to control the optional pull down on the MISO pin.

5.4 Electrical specifications

Table 125. ST25R39xxB electrical characteristics ($V_{DD} = 3.3\text{ V}$) ⁽¹⁾⁽²⁾

Symbol	Parameter	Conditions	Min	Typ	Max	Unit
I_{PD}	Supply current in Power-down mode	$T_{Jun} = -40\text{ °C to }25\text{ °C}$ ⁽³⁾	-	0.8	2.5	μA
		$T_{Jun} = 85\text{ °C}$ ⁽³⁾	-	2	20	
		$T_{Jun} = 125\text{ °C}$ ⁽³⁾	-	12	60	
I_{NFC}	Supply current in Initial NFC target mode	$T_{Jun} = -40\text{ °C to }25\text{ °C}$ ⁽⁴⁾	-	3.5	7.0	μA
		$T_{Jun} = 85\text{ °C}$ ⁽⁴⁾	-	4.25	20	
		$T_{Jun} = 125\text{ °C}$ ⁽⁴⁾	-	14	60	
I_{WU}	Supply current in Wake-up mode (logic and RC oscillator)	$T_{Jun} = -40\text{ °C to }25\text{ °C}$ ⁽⁵⁾	-	3.0	6.3	μA
		$T_{Jun} = 85\text{ °C}$ ⁽⁵⁾		3.8	20	
		$T_{Jun} = 125\text{ °C}$ ⁽⁵⁾		15	60	
I_{RD}	Supply current in Ready mode	⁽⁶⁾	-	4.5	7.5	mA
I_{AL}	Supply current all active	⁽⁷⁾	-	16	23	mA
I_{AWS}	Supply current all active, AWS	⁽⁸⁾	-	17	26	mA
R_{RFO}	RFO1 and RFO2 driver output resistance	$V_{RFO} = 150\text{ mV}$	-	1.7	4	Ω
R_{RFI}	RFI input resistance	-	-	12	16	$\text{k}\Omega$
V_{POR}	Power on reset voltage	-	1.0	1.45	2.0	V
V_{AGDC}	AGDC voltage	⁽⁶⁾	1.4	1.5	1.6	
V_{REG}	Regulated voltage	⁽⁹⁾	2.65	3.00	3.20	
R_{TAD}	Testpin output resistance	-	-	0.5	1.5	$\text{k}\Omega$

- 3.3 V supply mode with $V_{DD} = 3.3\text{ V}$, unless noted otherwise. Regulated voltages are set at 3.0 V, 27.12 MHz Xtal connected to XTO and XTI.
- Min and Max values tested in production at 25 °C, other temperature values evaluated by characterization.
- Registers 00h to 07h (no clock on MCU_CLK), 01h to 80h (3 V supply mode), other registers in default state.
- Registers 00h to 07h (no clock on MCU_CLK), 01h to 80h (3 V supply mode), 02h to 03h (external field detector enable), 03h to E8h (enable NFC Target mode), other registers in default state.
- Registers 00h to 07h (no clock on MCU_CLK), 01h to 80h (3 V supply mode), 02h to 04h (enable Wake-up mode), 32h to 08h (100 ms timeout, IRQ at every timeout), other registers in default state.
- Registers 00h to 07h (no clock on MCU_CLK), 01h to C0h (3 V supply mode, disable V_{DD_D}), 02h to 80h (en = 1), 2Ch to D8h (3.0 V regulator), other registers in default state, short V_{DD_A} and V_{DD_D} .
- Registers 00h to 07h (no clock on MCU_CLK), 01h to C0h (3 V supply mode, disable V_{DD_D}), 02h to C8h (enable RX, enable TX), 28h to 7Fh (RFO segments disabled), 2Ch to D8h (3.0 V regulator), other registers in default state, short V_{DD_A} and V_{DD_D} .
- Registers 00h to 07h (no clock on MCU_CLK), 01h to C0h (3 V supply mode, disable V_{DD_D}), 02h to C8h (enable RX, enable TX), 03h to 14h (AM modulation), 28h to 7Fh (RFO segments disabled), 2Ch to D8h (3.0 V regulator), other registers in default state, short V_{DD_A} and V_{DD_D} .
- Manual regulator mode, regulated voltage set to 3.0 V, measured on pin V_{DD_RF} : register 00h set to 0Fh, register 01h set to 80h (3 V supply mode), register 02h set to E8h (one channel RX, enable TX), 2Ch to D8h (3.0 V regulator), other registers in default state.

Table 126. ST25R39xxB electrical characteristics ($V_{DD} = 5.5\text{ V}$) ⁽¹⁾ ⁽²⁾

Symbol	Parameter	Conditions	Min	Typ	Max	Unit
I_{PD}	Supply current in Power-down mode	$T_{Jun} = -40\text{ to }25\text{ }^{\circ}\text{C}$ ⁽³⁾	-	1	3	μA
		$T_{Jun} = 125\text{ }^{\circ}\text{C}$ ⁽³⁾	-	-	90	
		$T_{Jun} = 85\text{ }^{\circ}\text{C}$	-	2.5	25	
I_{NFCT}	Supply current in initial NFC target mode	$T_{Jun} = -40\text{ to }25\text{ }^{\circ}\text{C}$ ⁽⁴⁾	-	3.4	8	
		$T_{Jun} = 125\text{ }^{\circ}\text{C}$ ⁽⁴⁾	-	35	90	
		$T_{Jun} = 85\text{ }^{\circ}\text{C}$	-	5	25	
I_{WU}	Supply current in Wake-up mode (logic and RC oscillator)	$T_{Jun} = -40\text{ to }25\text{ }^{\circ}\text{C}$ ⁽⁵⁾	-	3	8	
		$T_{Jun} = 125\text{ }^{\circ}\text{C}$ ⁽⁵⁾	-	15	90	
		$T_{Jun} = 85\text{ }^{\circ}\text{C}$	-	5	25	
I_{RD}	Supply current in Ready mode	⁽⁶⁾	-	5.6	7.5	mA
I_{AL}	Supply current all active	⁽⁷⁾	-	16.0	23.0	mA
I_{AWS}	Supply current all active, AWS	⁽⁸⁾	-	19.0	26.0	mA
R_{RFO}	RFO1 and RFO2 driver output resistance	$V_{RFO} = 150\text{ mV}$ ⁽⁹⁾	-	1.7	4	Ω
R_{RFI}	RFI input resistance	⁽⁹⁾ ⁽¹⁰⁾	-	12.5	16	$\text{k}\Omega$
V_{POR}	Power on reset voltage	-	1.00	1.45	2.00	V
V_{AGDC}	AGDC voltage	⁽⁷⁾	1.40	1.50	1.60	
V_{REG}	Regulated voltage	⁽⁷⁾	4.3	5.0	5.3	
R_{TAD}	Testpin output resistance	⁽⁹⁾	-	0.6	1.5	$\text{k}\Omega$

1. Min and Max values tested in production at $25\text{ }^{\circ}\text{C}$, other values evaluated by characterization.
2. 5.0 V supply mode with $V_{DD} = 5.5\text{ V}$ unless noted otherwise. Regulated voltages set to 5.1 V , 27.12 MHz crystal connected to XTO and XTI.
3. Registers 00h to 07h (no clock on MCU_CLK), 01h to 00h (5 V supply mode), other registers in default state.
4. Registers 00h to 07h (no clock on MCU_CLK), 01h to 00h (5 V supply mode), 02h to 03h (external field detector enable), 03h to E8h (enable NFC Target mode), other registers in default state.
5. Registers 00h to 07h (no clock on MCU_CLK), 01h to 00h (5 V supply mode), 02h to 04h (enable Wake-up mode), 32h to 08h (100 ms timeout, IRQ at every timeout), other registers in default state.
6. Registers 00h to 07h (no clock on MCU_CLK), 01h to 40h (5 V supply mode, disable VDD_D), 02h to 80h (en = 1), 2Ch to F8h (5.1 V regulator), other registers in default state, short VDD_A and VDD_D.
7. Registers 00h to 07h (no clock on MCU_CLK), 01h to 40h (5 V supply mode, disable VDD_D), 02h to C8h (enable RX, enable TX), 28h to 7Fh (RFO segments disabled), 2Ch to F8h (5.1 V regulator), other registers in default state, short VDD_A and VDD_D.
8. Registers 00h to 07h (no clock on MCU_CLK), 01h to 40h (5 V supply mode, disable VDD_D), 02h to C8h (enable RX, enable TX), 03h to 14h (AM modulation), 28h to 7Fh (RFO segments disabled), 2Ch to F8h (5.1 V regulator), other registers in default state, short VDD_A and VDD_D.
9. Evaluated by characterization - not tested in production.
10. $f_{SUB} = 848\text{ kHz}$, AM channel with peak detector input stage selected.

Table 127. ST25R39xxB electrical characteristics ($V_{DD} = 2.4\text{ V}$)⁽¹⁾ ⁽²⁾

Symbol	Parameter	Conditions	Min	Typ	Max	Unit
I_{PD}	Supply current in Power-down mode	$T_{J_{un}} = -40\text{ to }25\text{ }^{\circ}\text{C}$ ⁽³⁾	-	0.5	2.2	μA
		$T_{J_{un}} = 85\text{ }^{\circ}\text{C}$ ⁽³⁾	-	1.5	15	
		$T_{J_{un}} = 125\text{ }^{\circ}\text{C}$ ⁽³⁾		7.0	50	
I_{NFCT}	Supply current in initial NFC target mode	$T_{J_{un}} = -40\text{ to }25\text{ }^{\circ}\text{C}$ ⁽⁴⁾	-	1.5	5	
		$T_{J_{un}} = 85\text{ }^{\circ}\text{C}$ ⁽⁴⁾	-	2	15	
		$T_{J_{un}} = 125\text{ }^{\circ}\text{C}$ ⁽⁴⁾		8	50	
I_{WU}	Supply current in Wake-up mode (logic and RC oscillator)	$T_{J_{un}} = -40\text{ to }25\text{ }^{\circ}\text{C}$ ⁽⁵⁾	-	1.8	5	
		$T_{J_{un}} = 85\text{ }^{\circ}\text{C}$ ⁽⁵⁾	-	2.7	15	
		$T_{J_{un}} = 125\text{ }^{\circ}\text{C}$ ⁽⁵⁾		9	50	
I_{RD}	Supply current in Ready mode	⁽⁶⁾	-	3.4	7.5	mA
I_{AL}	Supply current all active	⁽⁷⁾	-	14	23	mA
I_{AWS}	Supply current all active, AWS	⁽⁸⁾	-	15	26	mA
R_{RFO}	RFO1 and RFO2 driver output resistance	$V_{RFO} = 150\text{ mV}$ ⁽⁹⁾	-	1.7	4	Ω
R_{RFI}	RFI input resistance	⁽⁹⁾ ⁽¹⁰⁾	-	12	16	k Ω
V_{POR}	Power on reset voltage	-	1.00	1.45	2.00	V
V_{AGDC}	AGDC voltage	⁽⁷⁾	1.40	1.50	1.60	
V_{REG}	Regulated voltage	⁽⁷⁾	2.20	2.40	2.45	
R_{TAD}	Testpin output resistance	⁽⁹⁾	-	0.5	1.5	k Ω

1. Min and Max values tested in production at 25 °C, other values evaluated by characterization.
2. 3.3 V supply mode with $V_{DD} = 2.4\text{ V}$ unless noted otherwise. Regulated voltages set to 2.4 V, 27.12 MHz crystal connected to XTO and XTI.
3. Registers 00h to 07h (no clock on MCU_CLK), 01h to 80h (3 V supply mode), other registers in default state.
4. Registers 00h to 07h (no clock on MCU_CLK), 01h to 80h (3 V supply mode), 02h to 03h (external field detector enable), 03h to E8h (enable NFC Target mode), other registers in default state.
5. Registers 00h to 07h (no clock on MCU_CLK), 01h to 80h (3 V supply mode), 02h to 04h (enable Wake-up mode), 32h to 08h (100 ms timeout, IRQ at every timeout), other registers in default state.
6. Registers 00h to 07h (no clock on MCU_CLK), 01h to C0h (3 V supply mode, disable VDD_D), 02h to 80h (en = 1), 2Ch to A8h (2.4 V regulator), other registers in default state, short VDD_A and VDD_D.
7. Registers 00h to 07h (no clock on MCU_CLK), 01h to C0h (3 V supply mode, disable VDD_D), 02h to C8h (enable RX, enable TX), 28h to 7Fh (RFO segments disabled), 2Ch to A8h (2.4 V regulator), other registers in default state, short VDD_A and VDD_D.
8. Registers 00h to 07h (no clock on MCU_CLK), 01h to C0h (3 V supply mode, disable VDD_D), 02h to C8h (enable RX, enable TX), 03h to 14h (AM modulation), 28h to 7Fh (RFO segments disabled), 2Ch to A8h (2.4 V regulator), other registers in default state, short VDD_A and VDD_D.
9. Evaluated by characterization - not tested in production.
10. $f_{SUB} = 848\text{ kHz}$, AM channel with peak detector input stage selected.

5.5 SPI interface characteristics

Table 128. SPI characteristics (5 MHz) ⁽¹⁾

Operation	Symbol	Parameter	Conditions	Min	Typ	Max	Unit
General	T _{SCLK}	SCLK period	T _{SCLK} = T _{SCLKL} + T _{SCLKH}	-	200	-	ns
	T _{SCLKL}	SCLK low	-	95	-	-	
	T _{SCLKH}	SCLK high	-	95	-	-	
	T _{SSH}	SPI reset (BSS high)	-	100	-	-	
	T _{NCSL}	BSS falling to SCLK rising	First SCLK pulse	25	-	-	
	T _{NCSH}	SCLK falling to BSS rising	Last SCLK pulse	25	-	-	
	T _{DIS}	Data in setup time	-	10	-	-	
	T _{DIH}	Data in hold time	-	10	-	-	
Read	T _{DOD}	Data out delay	C _{load} ≤ 50 pF, V _{DD_IO} = 1.65 to 3.0 V	-	80	95	
			C _{load} ≤ 50 pF, V _{DD_IO} = 3.0 to 5.5 V	-	-	70	
	T _{DOHZ}	Data out to high impedance delay	C _{load} ≤ 50 pF	-	20	-	

1. Evaluated by characterization - not tested in production.

Table 129. SPI characteristics (5 MHz < 1/T_{SCLK} < 10 MHz) ⁽¹⁾

Operation	Symbol	Parameter	Conditions	Min	Typ	Max	Unit
General	T _{SCLK}	SCLK period	T _{SCLK} = T _{SCLKL} + T _{SCLKH}	100	-	-	ns
	T _{SCLKL}	SCLK low	-	40	-	-	
	T _{SCLKH}	SCLK high	-	40	-	-	
	T _{SSH}	SPI reset (BSS high)	-	100	-	-	
	T _{NCSL}	BSS falling to SCLK rising	First SCLK pulse	25	-	-	
	T _{NCSH}	SCLK falling to BSS rising	Last SCLK pulse	25	-	-	
	T _{DIS}	Data in setup time	-	10	-	-	
	T _{DIH}	Data in hold time	-	10	-	-	
Read	T _{DOD}	Data out delay	C _{load} ≤ 50 pF, V _{DD_IO} = 3.0 to 5.5 V	-	55	70	
	T _{DOHZ}	Data out to high impedance delay	C _{load} ≤ 50 pF	-	20	-	

1. Evaluated by characterization - not tested in production.

Figure 32. SPI timing diagram - General operation

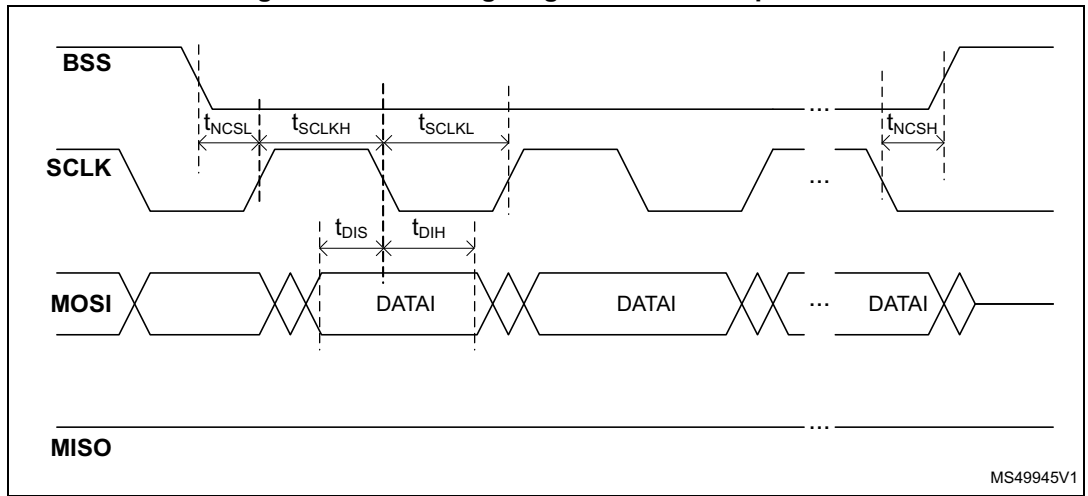
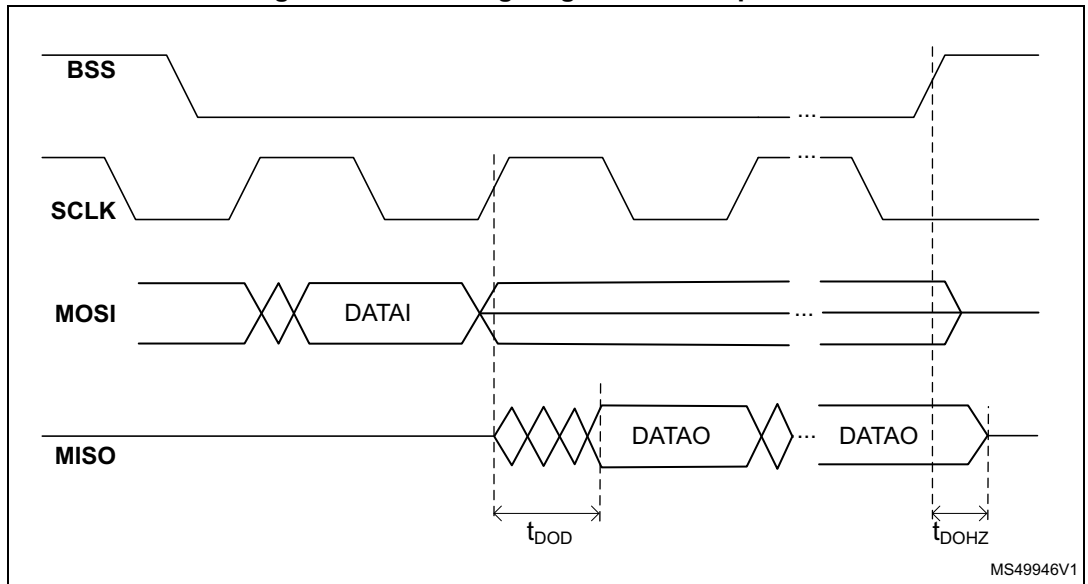

Figure 33. SPI timing diagram - Read operation



5.6 I2C interface characteristics

Timing according to I2C protocol. Drivers for up to 3.4 MHz operation.

Transition from 100 kHz / 400 kHz / 1 MHz mode to 3.4 MHz mode (High speed mode) is done via controller code 00001XXX, as described in the I2C specification.

Table 130. AC measurement conditions

Symbol	Parameter	Min	Max	Unit
C _{BUS}	Load capacitance	100		pF
-	SCL input rise/fall time, SDA input fall time	-	50	ns

Table 131. AC measurement conditions - I2C configuration

Mode	Rate	Setting
S	100 kHz	i2c_thd = 00b, io_drv_lvl = 1b
F	400 kHz	i2c_thd = 01b, io_drv_lvl = 1b
F+	1000 kHz	i2c_thd = 11b, io_drv_lvl = 1b
HS	3400 kHz	i2c_thd = 11b, io_drv_lvl = 1b

Table 132. Input parameters⁽¹⁾

Symbol	Parameter	Conditions	Min	Max	Unit
C _{IN}	Input capacitance (SDA)	-	-	15	pF
	Input capacitance (SCL)	-	-	15	

1. Evaluated by characterization - not tested in production.

Table 133. DC characteristics⁽¹⁾

Symbol	Parameter	Conditions (in addition to those in Table 130 and Table 131)	Min	Max	Unit
I _{LI}	Input leakage current (SCL, SDA)	V _{IN} = V _{SS} or V _{CC} , device in Standby mode	-	± 10	µA
I _{LO}	Output leakage current	SDA in Hi-Z, external voltage applied on SDA: V _{SS} or V _{CC}	-	± 10	
V _{IL}	Input low voltage (SCL, SDA)	-	-0.4	0.2 V _{DD_IO}	V
V _{IH}	Input high voltage (SCL, SDA)	-	0.8 V _{DD_IO}	V _{DD_IO} + 0.4	
V _{OL}	Output low voltage	V _{DD_IO} = 1.65 V, I _{OL} = 2.5 mA	-	0.1 V _{DD_IO}	
		V _{DD_IO} = 2.4 V, I _{OL} = 3.0 mA	-	0.1 V _{DD_IO}	
		V _{DD_IO} = 3.3 V, I _{OL} = 8 mA	-	0.1 V _{DD_IO}	
		V _{DD_IO} = 5.5 V, I _{OL} = 8 mA	-	0.1 V _{DD_IO}	

1. Evaluated by characterization - not tested in production.

Table 134. 100 kHz AC characteristics⁽¹⁾

Symbol	Alt.	Parameter	Min	Max	Unit
f_C	f_{SCL}	Clock frequency	-	100	kHz
t_{CHCL}	t_{HIGH}	Clock pulse width high	4000	-	ns
t_{CLCH}	t_{LOW}	Clock pulse width low	4700	-	
t_{QL1QL2}	t_F	SDA (out) fall time	-	300	
t_{DXCH}	$t_{SU:DAT}$	Data in set up time	250	-	
t_{CLDX^X}	$t_{HD:DAT}$	Data in hold time	5000	-	
t_{CLQX}	t_{DH}	Data out hold time	50	-	
t_{CLQV}	t_{AA}	Clock low to next data valid (access time)	-	3450	
t_{CHDL}	$t_{SU:STA}$	Start condition setup time	4700	-	
t_{DLCL}	$t_{HD:STA}$	Start condition hold time	4000	-	
t_{CHDH}	$t_{SU:STO}$	Stop condition set up time	4000	-	
t_{DHDL}	t_{BUF}	Time between Stop condition and next Start condition	4700	-	
$t_{NS}^{(2)}$	-	Pulse width ignored (input filter on SCL and SDA), single glitch	-	40	

1. Conditions in addition to those specified in [Table 130](#) and [Table 131](#).
2. Evaluated by characterization - not tested in production.

Table 135. 400 kHz AC characteristics^{(1) (2)}

Symbol	Alt.	Parameter	Min	Max	Unit
f_C	f_{SCL}	Clock frequency	-	400	kHz
t_{CHCL}	t_{HIGH}	Clock pulse width high	600	-	ns
t_{CLCH}	t_{LOW}	Clock pulse width low	1300	-	
t_{QL1QL2}	t_F	SDA (out) fall time	-	300	
t_{DXCH}	$t_{SU:DAT}$	Data in set up time	100	-	
t_{CLDX^X}	$t_{HD:DAT}$	Data in hold time	0	-	
t_{CLQX}	t_{DH}	Data out hold time	50	-	
t_{CLQV}	t_{AA}	Clock low to next data valid (access time)	-	900	
t_{CHDL}	$t_{SU:STA}$	Start condition setup time	600	-	
t_{DLCL}	$t_{HD:STA}$	Start condition hold time	600	-	
t_{CHDH}	$t_{SU:STO}$	Stop condition set up time	600	-	
t_{DHDL}	t_{BUF}	Time between Stop condition and next Start condition	1300	-	
t_{NS}	-	Pulse width ignored (input filter on SCL and SDA), single glitch	-	40	

1. Conditions in addition to those specified in [Table 130](#) and [Table 131](#).
2. Evaluated by characterization - not tested in production.

Table 136. 1 MHz AC characteristics⁽¹⁾⁽²⁾

Symbol	Alt.	Parameter	Min	Max	Unit
f_C	f_{SCL}	Clock frequency	-	1	MHz
t_{CHCL}	t_{HIGH}	Clock pulse width high	260	-	ns
t_{CLCH}	t_{LOW}	Clock pulse width low	500	-	
t_{QL1QL2}	t_F	SDA (out) fall time	-	120	
t_{DXCH}	$t_{SU:DAT}$	Data in set up time	50	-	
t_{CLDX}^X	$t_{HD:DAT}$	Data in hold time	0	-	
t_{CLQX}	t_{DH}	Data out hold time	50	-	
t_{CLQV}	t_{AA}	Clock low to next data valid (access time)	-	450	
t_{CHDL}	$t_{SU:STA}$	Start condition setup time	250	-	
t_{DLCL}	$t_{HD:STA}$	Start condition hold time	250	-	
t_{CHDH}	$t_{SU:STO}$	Stop condition set up time	250	-	
t_{DHDL}	t_{BUF}	Time between Stop condition and next Start condition	500	-	
t_{NS}	-	Pulse width ignored (input filter on SCL and SDA), single glitch	-	40	

1. Conditions in addition to those specified in [Table 130](#) and [Table 131](#).
2. Evaluated by characterization - not tested in production.

Table 137. 3.4 MHz AC characteristics⁽¹⁾⁽²⁾⁽³⁾

Symbol	Alt.	Parameter	Min	Max	Unit
f_C	f_{SCL}	Clock frequency	-	3.4	MHz
t_{CHCL}	t_{HIGH}	Clock pulse width high	80	-	ns
t_{CLCH}	t_{LOW}	Clock pulse width low	160	-	
t_{QL1QL2}	t_F	SDA (out) fall time (10-100 pF)	-	41	
t_{DXCH}	$t_{SU:DAT}$	Data in set up time	25	-	
t_{CLDX}^X	$t_{HD:DAT}$	Data in hold time	0	-	
t_{CLQX}	t_{DH}	Data out hold time	20	-	
t_{CLQV}	t_{AA}	Clock low to next data valid	-	150	
t_{CHDL}	$t_{SU:STA}$	Start condition setup time	160	-	
t_{DLCL}	$t_{HD:STA}$	Start condition hold time	160	-	
t_{CHDH}	$t_{SU:STO}$	Stop condition set up time	160	-	
t_{NS}	-	Pulse width ignored (input filter on SCL and SDA), single glitch	-	10	

1. Conditions in addition to those specified in [Table 130](#) and [Table 131](#).
2. Evaluated by characterization - not tested in production.
3. V_{DD_IO} supply must not exceed V_{DD} .

Figure 34. R_{pmin} vs. V_{DD} , $f_c = 3.4$ MHz

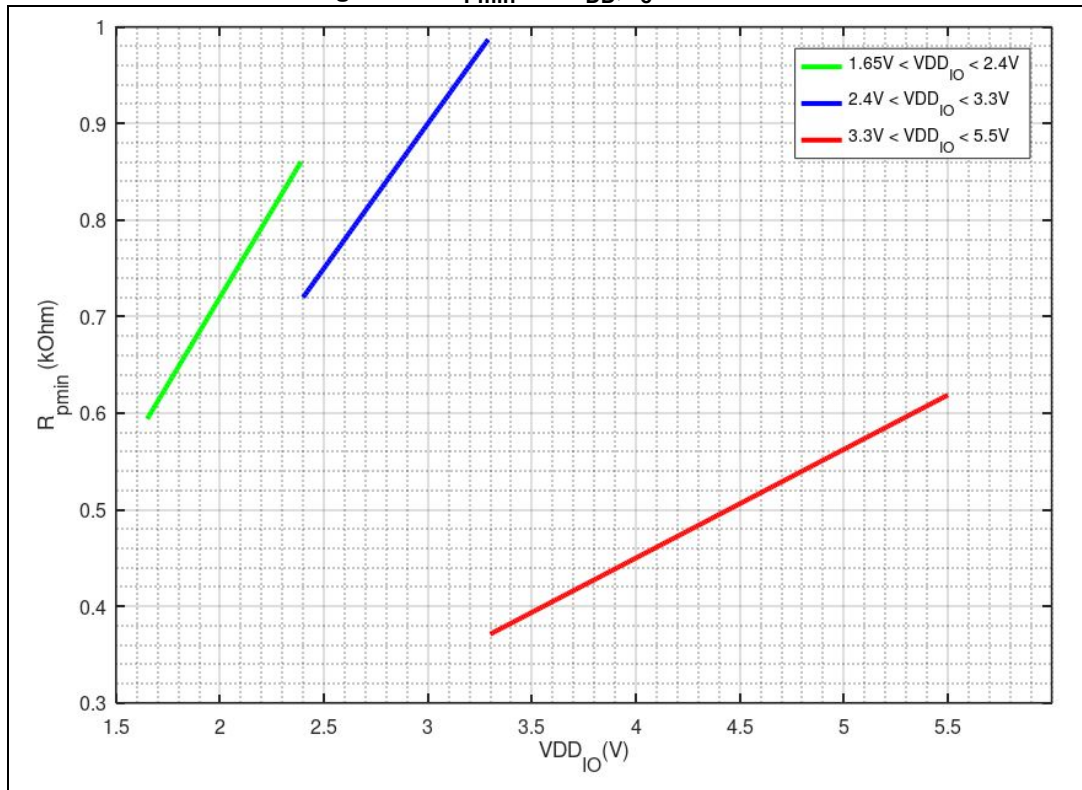
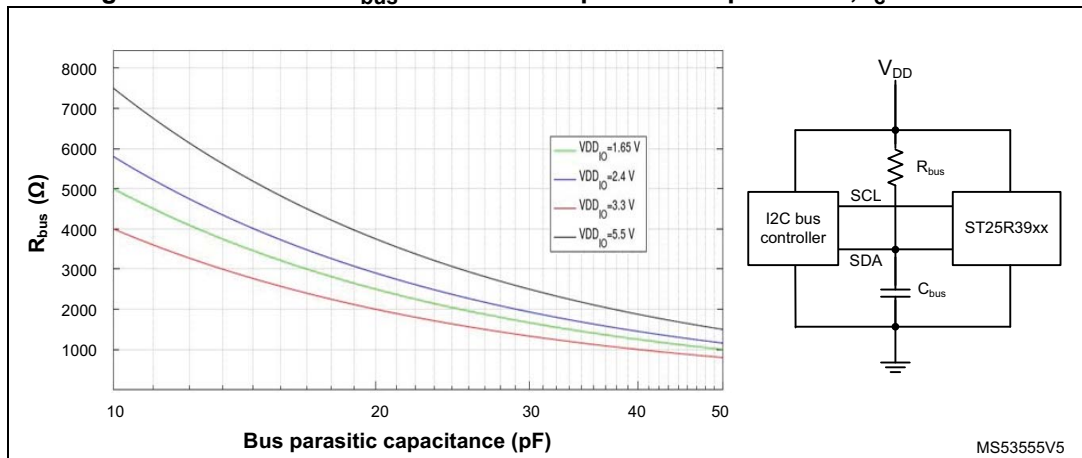

Figure 35. Maximum R_{bus} value vs. bus parasitic capacitance, $f_c = 3.4$ MHz



6 Package information

To meet environmental requirements, ST offers these devices in different grades of ECOPACK packages, depending on their level of environmental compliance. ECOPACK specifications, grade definitions and product status are available at www.st.com.

ECOPACK is an ST trademark.

6.1 VFQFPN32 package information

VFQFPN32 is a 32-pin, 5x5 mm, 0.5 mm pitch, very thin fine pitch quad flat no lead package.

Figure 38. VFQFPN32 - Outline

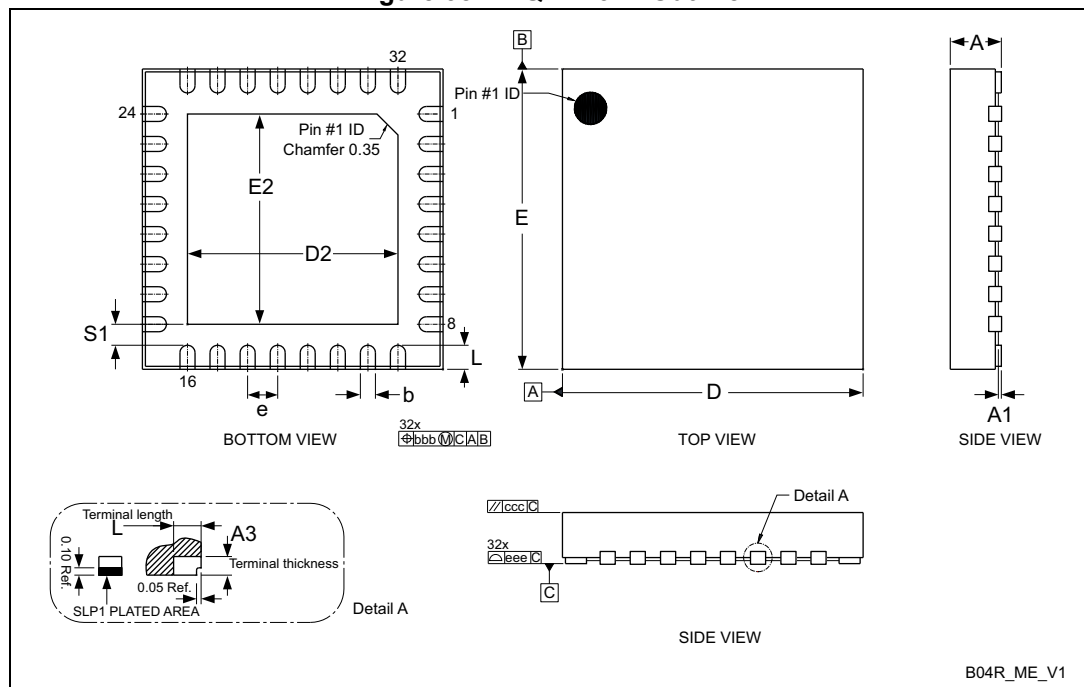

1. Drawing is not to scale.
2. Coplanarity applies to the exposed pad as well as the terminal.

Table 138. VFQFPN32 - Mechanical data

Symbol	millimeters			inches ⁽¹⁾		
	Min	Typ	Max	Min	Typ	Max
A	0.800	0.900	1.000	0.0315	0.0354	0.0394
A1	0	-	0.050	0	-	0.0020
A3	0.200			0.0079		
L	0.300	0.400	0.500	0.0118	0.0157	0.0197

Table 138. VFQFPN32 - Mechanical data (continued)

Symbol	millimeters			inches ⁽¹⁾		
	Min	Typ	Max	Min	Typ	Max
b	0.180	0.250	0.300	0.0071	0.0098	0.0118
D	5.000			0.1969		
D2	3.400	3.500	3.600	0.1339	0.1378	0.1417
E	5.000			0.1969		
E2	3.400	3.500	3.600	0.1339	0.1378	0.1417
e	0.500			0.0197		
S1	0.350			0.0138		
bbb	-	0.100	-	-	0.0039	-
ccc	-	0.100	-	-	0.0039	-
eee	-	0.080	-	-	0.0031	-

1. Values in inches are converted from mm and rounded to four decimal digits.

Figure 39. VFQFPN32 - Footprint example

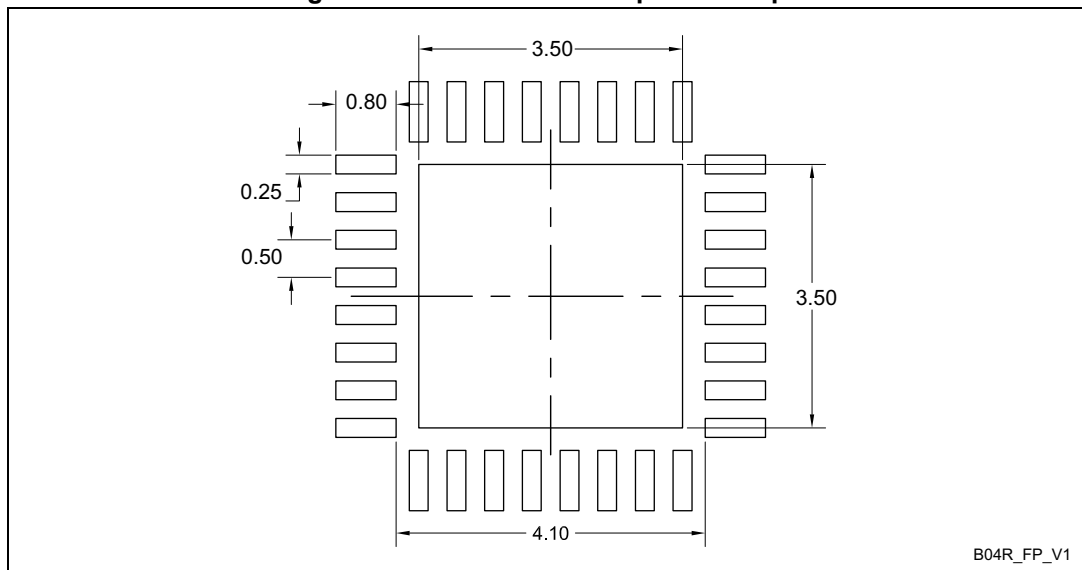

1. Dimensions are expressed in millimeters.

6.2 UFQFPN32 package information (A0B8)

This UFQFPN is a 32-pin, 5 x 5 mm, 0.5 mm pitch ultrathin fine pitch quad flat package.

Note: *Figure 40 and Figure 41 are not to scale.*
 Refer to the notes section for the list of notes on *Figure 40, Table 139, and Table 140.*

Figure 40. UFQFPN32 - Outline

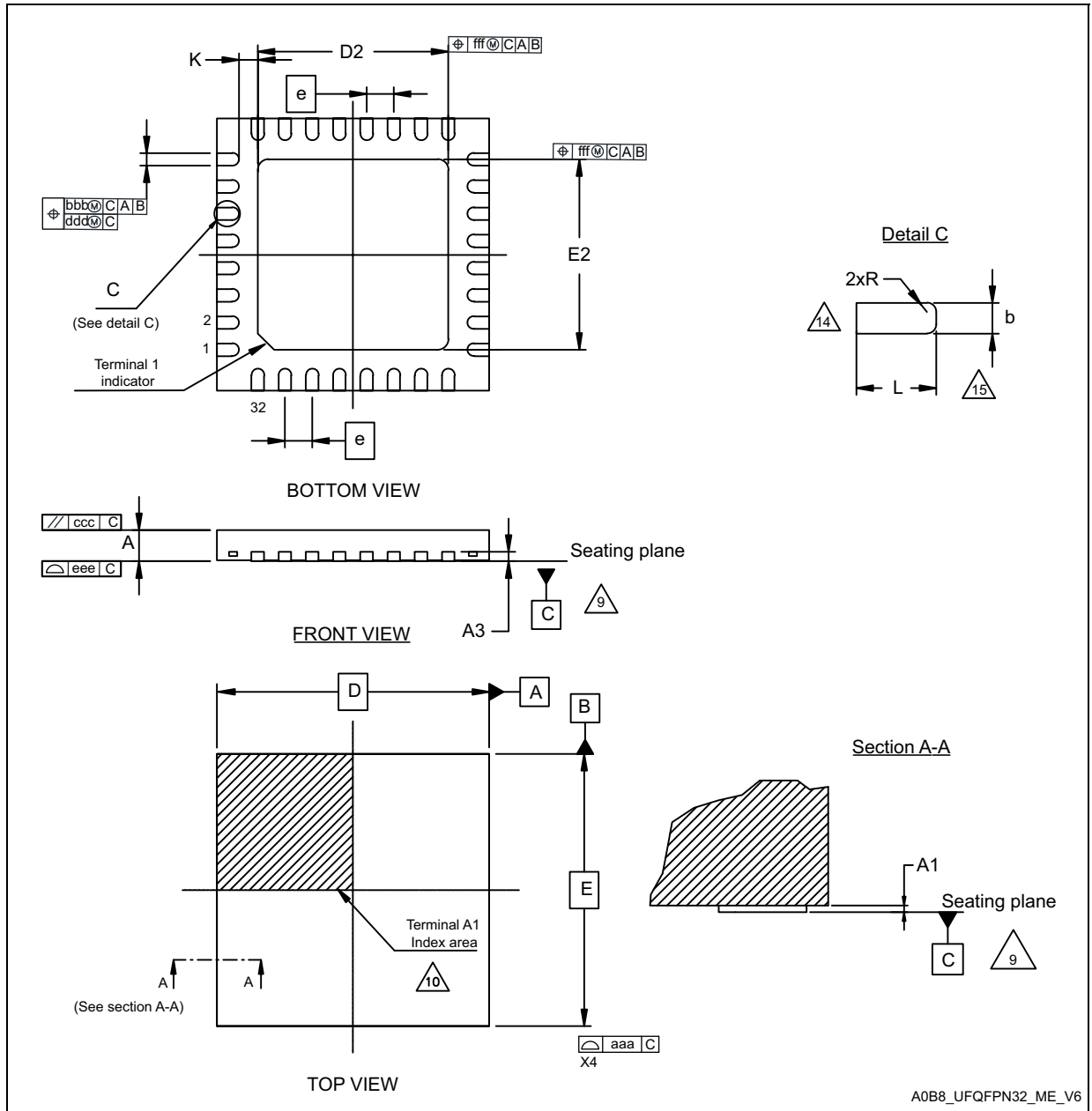

Table 139. UFQFPN32 - Mechanical data

Symbol	Millimeters			Inches ⁽⁸⁾		
	Min	Typ	Max	Min	Typ	Max
A ⁽²⁾⁽³⁾	0.50	0.55	0.60	0.0197	0.0217	0.0236
A1 ⁽⁴⁾	0.00	-	0.05	0.000	-	0.0020
b ⁽⁶⁾⁽¹⁵⁾	0.18	0.25	0.30	0.0071	0.0098	0.0118
D ⁽⁷⁾	5.00 BSC			0.1969 BSC		
D2	3.40	3.50	3.60	0.1339	0.1378	0.1417
E ⁽⁷⁾	5.00 BSC			0.1969 BSC		
E2	3.40	3.50	3.60	0.1339	0.1378	0.1417
e	0.50 BSC			0.0197 BSC		
N ⁽¹²⁾	32					
L ⁽¹⁵⁾	0.30	-	0.50	0.0118	-	0.0197
R	0.09	-	-	0.0035	-	-

Table 140. Tolerance of form and position

Symbol	Millimeters	Inches ⁽⁸⁾
aaa	0.15	0.0059
bbb	0.10	0.0039
ccc	0.10	0.0039
ddd	0.05	0.0020
eee	0.08	0.0315
fff	0.10	0.0039

Notes:

1. Dimensioning and tolerancing schemes conform to ASME Y14.5M-2018 except for European.
2. UFQFPN stands for ultra-thin fine pitch quad flat package no lead: $A \leq 0.60$ mm / Fine pitch $e \leq 1.00$ mm.
3. The profile height, A, is the distance from the seating plane to the highest point on the package. It is measured perpendicular to the seating plane.
4. A1 is the vertical distance from the bottom surface of the plastic body to the nearest metallized package feature.
5. A3 is the distance from the seating plane to the upper surface of the terminals.
6. Dimension b applies to metallized terminal. If the terminal has the optional radius on the other end of the terminal, the dimension b should not be measured in that radius area.
7. BSC stands for BASIC dimensions. It corresponds to the nominal value and has no tolerance.
8. Values in inches are converted from millimeters and rounded to four decimal digits.
9. Primary datum C is defined by the plane established by the contact points of three or more solder balls that support the device when it is placed on top of a planar surface.
10. Terminal A1 identifier and terminal numbering convention must conform to JEP95 SPP-002. Terminal A1 identifier must be located within the zone indicated on the outline drawing. Topside terminal A1 indicator may be a molded, or metallized feature. Optional indicator on bottom surface may be a molded, marked, or metallized feature.
11. ddd coplanarity zone applies to the exposed pad as well as the terminals.
12. N represents the total number of terminals.
13. K gives the minimum separation between any two terminals or the terminals and the edges of the exposed metal heat feature.
14. The inner edge of corner terminals may be chamfered or rounded to achieve minimum gap k. This feature should not affect the terminal width b, which is measured L/2 from the edge of the package body.
15. Dimension b and L are measured at the terminal planting surface.

Figure 41. UFQFPN32 - Footprint example

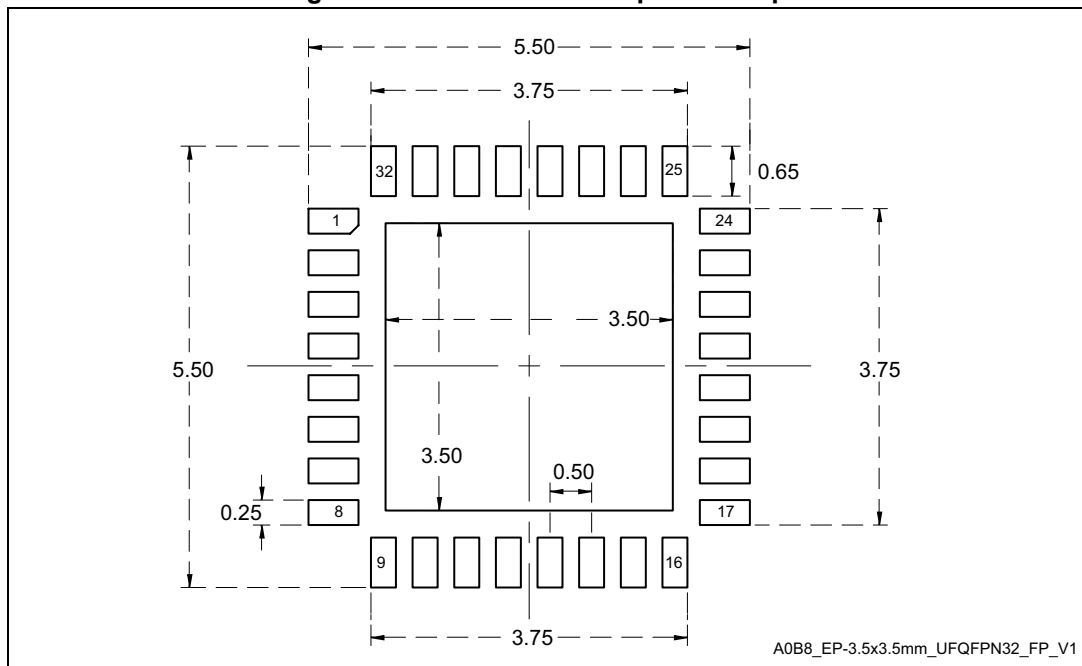

Note: Dimensions are expressed in millimeters.

6.3 WLCSP36 package information

This WLCSP is a 36 balls, 3.223 x 3.213 mm, 0.5 mm pitch, wafer level chip scale package.

Figure 42. WLCSP36 - Outline

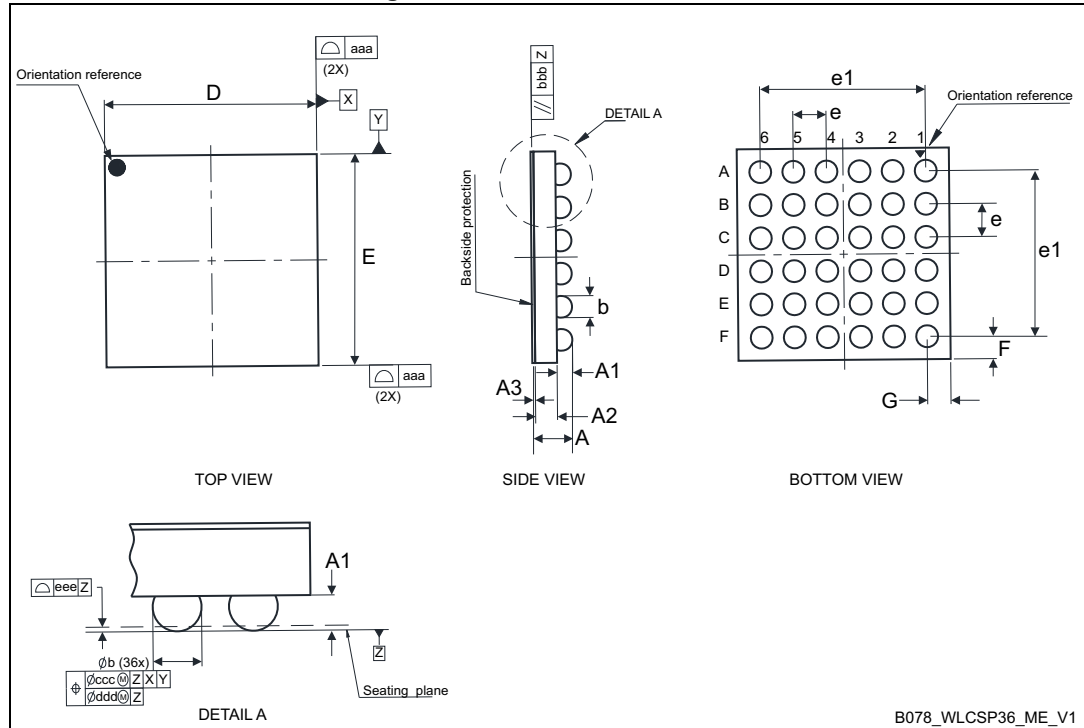

1. Drawing is not to scale.
2. Dimension is measured at the maximum bump diameter parallel to primary datum Z.
3. Primary datum Z and seating plane are defined by the spherical crowns of the bump.
4. Bump position designation per JESD 95-1, SPP-010.

Table 141. WLCSP36 - Mechanical data

Symbol	millimeters			inches ⁽¹⁾		
	Min	Typ	Max	Min	Typ	Max
A	0.550	0.590	0.630	0.0217	0.0232	0.0248
A1	-	0.235	-	-	0.0093	-
A2	-	0.330	-	-	0.0130	-
A3 ⁽²⁾	-	0.025	-	-	0.0010	-
b	-	0.330	-	-	0.0130	-
D	3.203	3.223	3.243	0.1261	0.1269	0.1277
E	3.193	3.213	3.233	0.1257	0.1265	0.1273
e	-	0.500	-	-	0.0197	-
e1	-	2.500	-	-	0.0984	-
F	-	0.357	-	-	0.0141	-

Table 141. WLCSP36 - Mechanical data (continued)

Symbol	millimeters			inches ⁽¹⁾		
	Min	Typ	Max	Min	Typ	Max
G	-	0.362	-	-	0.0143	-
aaa	-	0.100	-	-	0.0039	-
bbb	-	0.100	-	-	0.0039	-
ccc	-	0.100	-	-	0.0039	-
ddd	-	0.050	-	-	0.002	-
eee	-	0.050	-	-	0.002	-

1. Values in inches are converted from mm and rounded to 4 decimal digits.
2. Back side coating.

Figure 43. WLCSP36 - Footprint example

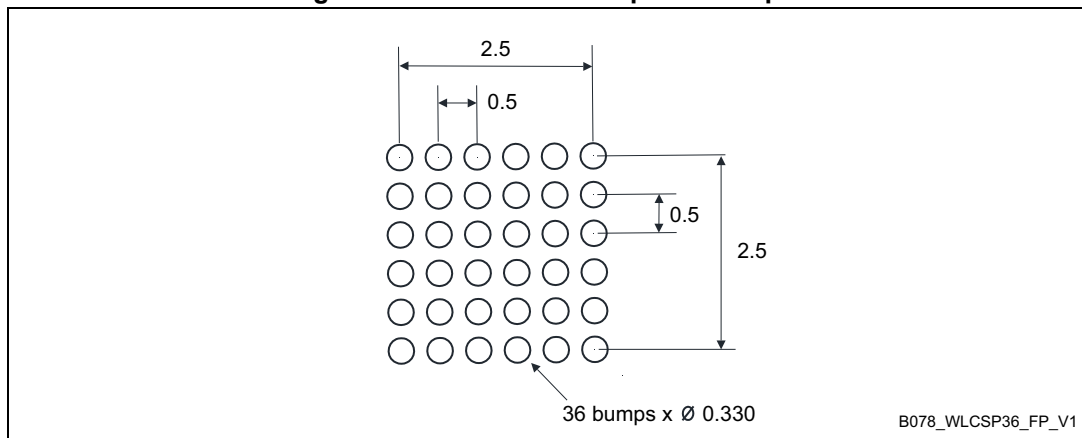

1. Dimensions are expressed in millimeters.

7 Ordering information

Table 142. Ordering information scheme

Example:	ST25	R	3916B	-A	QW	T
Device type ST25 = NFC/RFID tags and readers						
Product type R = NFC/HF reader						
Product feature 3916B = Full feature NFC reader for payment, consumer and industrial 3917B = NFC reader for payment, consumer and industrial 3919B = NFC-A/B/V reader for consumer and industrial						
Ambient temperature range A = -40 °C to 105 °C B = -40 °C to 85 °C						
Package/Packaging QE = 32-pin UFQFPN (5 x 5 x 0.55 mm) with non-wettable flanks QW = 32-pin VFQFPN (5 x 5 mm) with wettable flanks WL = WLCSP						
Tape and reel T = 4000 pcs/reel (VFQFPN), 5000 pcs/reel (WLCSP)						

Note: For a list of available options (speed, package, etc.) or for further information on any aspect of this device, contact your nearest ST sales office.

Note: Parts marked as “ES”, “E” or accompanied by an Engineering Sample notification letter, are not yet qualified and therefore not approved for use in production. ST is not responsible for any consequences resulting from such use. In no event will ST be liable for the customer using any of these engineering samples in production. ST’s Quality department must be contacted prior to any decision to use these engineering samples to run a qualification activity.

8 Revision history

Table 143. Document revision history

Date	Revision	Changes
25-Mar-2022	1	Initial release.
08-Apr-2022	2	Updated: <ul style="list-style-type: none"> – Features – Section 4.4.5: NFC field ON commands – Section 4.5.52: External field detector activation threshold register – Section 4.5.54: External field detector deactivation threshold register
27-Apr-2022	3	Updated: <ul style="list-style-type: none"> – Section 4.5.43: Number of transmitted bytes register 2
06-Jun-2022	4	Updated: <ul style="list-style-type: none"> – Table 121: IC identity register
15-Sep-2022	5	Updated: <ul style="list-style-type: none"> – Features – Table 2: ST25R3916B - VFQFPN32, UFQFPN32 and WLCSP36 pin assignment – Table 3: ST25R3917B/ST25R3919B VFQFPN32 and UFQFPN32 pin assignment – Figure 6: ST25R3916B WLCSP36 (top view) – Section 4.2.12: Active wave shaping – Table 7: Typical preset values for slow, medium and fast transients in OOK and ASK – Table 11: Serial data interface (4-wire interface) signal lines – Table 39: VFQFPN32 - Footprint example – Table 142: Ordering information scheme Added: <ul style="list-style-type: none"> – Section 6.3: WLCSP36 package information
02-Nov-2022	6	Updated: <ul style="list-style-type: none"> – Figure 1: Minimum system configuration - Single sided antenna driving – Figure 2: Minimum system configuration - Differential antenna driving – Figure 4: ST25R3916B QFN32 pinout (top view) – Figure 5: ST25R3917B and ST25R3919B QFN32 pinout (top view) – Figure 6: ST25R3916B WLCSP36 (top view) – Table 2: ST25R3916B - VFQFPN32, UFQFPN32 and WLCSP36 pin assignment – Table 3: ST25R3917B/ST25R3919B VFQFPN32 and UFQFPN32 pin assignment – Section 5.4: Electrical specifications – Table 142: Ordering information scheme
15-Mar-2023	7	Added: <ul style="list-style-type: none"> – Section 6.2: UFQFPN32 package information (A0B8) Updated: <ul style="list-style-type: none"> – Figure 1: Minimum system configuration - Single sided antenna driving – Table 142: Ordering information scheme

Table 143. Document revision history (continued)

Date	Revision	Changes
09-May-2023	8	Added the ST25R3919B device. Updated: <ul style="list-style-type: none"> – Section 1: Applications – Table 1: List of features – Section 2: Description – Figure 1: Minimum system configuration - Single sided antenna driving – Figure 2: Minimum system configuration - Differential antenna driving – Figure 3: ST25R39xxB block diagram – Figure 5: ST25R3917B and ST25R3919B QFN32 pinout (top view) – Table 2: ST25R3916B - VFQFPN32, UFQFPN32 and WLCSP36 pin assignment – Table 3: ST25R3917B/ST25R3919B VFQFPN32 and UFQFPN32 pin assignment – Section 4.2.3: Antenna tuning – Section 4.2.4: Wake-up mode – Table 142: Ordering information scheme
11-Dec-2024	9	Updated: <ul style="list-style-type: none"> – Table 2: ST25R3916B - VFQFPN32, UFQFPN32 and WLCSP36 pin assignment – Table 3: ST25R3917B/ST25R3919B VFQFPN32 and UFQFPN32 pin assignment – Table 41: Receiver configuration register 2 – Table 48: Mask receive timer register – Table 53: General purpose timer register 1 – Table 54: General purpose timer register 2 – Table 80: Passive target modulation register – Table 86: External field detector deactivation threshold register
08-Jul-2025	10	Updated: <ul style="list-style-type: none"> – Features – Section 1: Applications – Section 2: Description – Figure 28: Read and Write mode for register space-B access
13-Mar-2026	11	Updated: <ul style="list-style-type: none"> – Table 21: IO configuration register 2 – Section 6.2: UFQFPN32 package information (A0B8)

IMPORTANT NOTICE – READ CAREFULLY

STMicroelectronics NV and its subsidiaries (“ST”) reserve the right to make changes, corrections, enhancements, modifications, and improvements to ST products and/or to this document at any time without notice.

In the event of any conflict between the provisions of this document and the provisions of any contractual arrangement in force between the purchasers and ST, the provisions of such contractual arrangement shall prevail.

The purchasers should obtain the latest relevant information on ST products before placing orders. ST products are sold pursuant to ST's terms and conditions of sale in place at the time of order acknowledgment.

The purchasers are solely responsible for the choice, selection, and use of ST products and ST assumes no liability for application assistance or the design of the purchasers' products.

No license, express or implied, to any intellectual property right is granted by ST herein.

Resale of ST products with provisions different from the information set forth herein shall void any warranty granted by ST for such product.

If the purchasers identify an ST product that meets their functional and performance requirements but that is not designated for the purchasers' market segment, the purchasers shall contact ST for more information.

ST and the ST logo are trademarks of ST. For additional information about ST trademarks, refer to www.st.com/trademarks. All other product or service names are the property of their respective owners.

Information in this document supersedes and replaces information previously supplied in any prior versions of this document.

© 2026 STMicroelectronics – All rights reserved