

0.5mm and 1.0mm Pitch Connector for FFC/FPC

TF31 Series

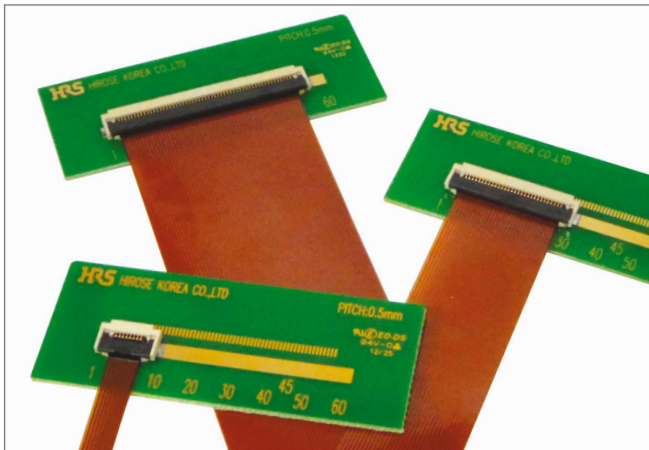

Compatible with other popular Hirose connectors

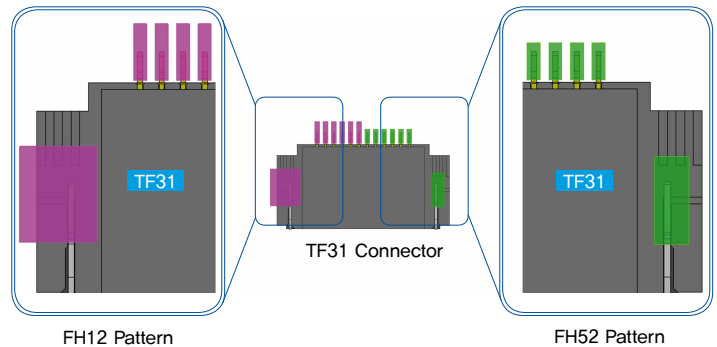

Figure.1

■ Features

1. Cost-effective and compatible with other popular Hirose connectors

The TF31 series utilizes the same FFC/FPC and PCB mounting patterns as two of Hirose's most popular connectors, the FH12 and FH52 series. This flexibility allows you to replace the FH12 and FH52 with the TF31 without having to re-design the board, providing a cost-effective solution. (see figure.1)

2. Multiple height and pitch variations available

This series offers two different contact pitches of 0.5 and 1.0 mm and two different heights of 1.75 and 2.0 mm. These options give engineers the ability to choose which connector will best fit their applications design. (See figure. 2)

3. FPC side catcher design

The TF31 series incorporates Hirose's FPC side catcher technology. This design feature puts the tabbed FPC into the correct position and also helps to achieve stability and deliver excellent retention force of the FPC. (See figure. 3)

4. Easy FPC insertion

The actuator has been designed to open to a wide, 110 degrees. This wide of an opening provides an easier, user friendly FPC insertion operation.

5. Prevents actuator separation

Each terminal is attached to the actuator, which provides support to the actuator across its whole length. This prevents the actuator from separating from the housing.

6. Actuator protection

The TF31 series has adopted an interference design that prevents the actuator from unintentionally opening. This prevents any damage that might occur when the mounted connector is transported, handled or placed into stock.

7. Maximizes board space

The bottom surface of the connector is over-molded. This allows the PCB space under the connector to be utilized for additional patterning.

8. Automatic board placement capable

The wide upper surface area of the connector and the tape and reel packaging allow this product to be utilized with automatic "pick-and-place" equipment.

9. RoHS compliant, and halogen free

The TF31 is compliant to the current RoHS and halogen-free standards.

※ As defined by IEC61249-2-21
Br 900ppm or less, Cl 900 ppm or less, Br + Cl 1,500 ppm or less

Multiple height and pitch variations available

Pitch variations

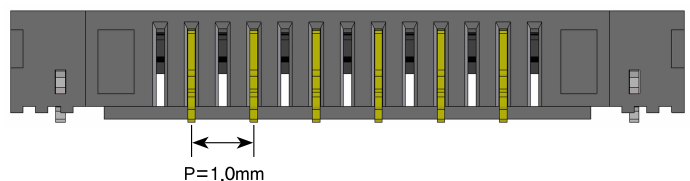
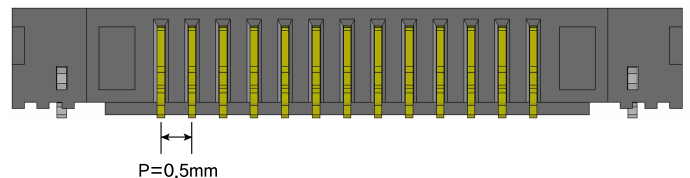

Height variations

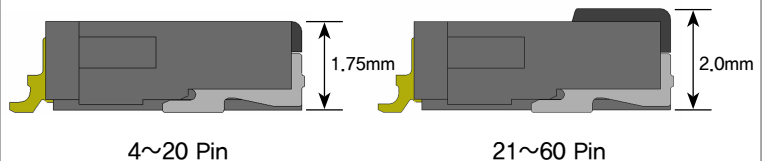
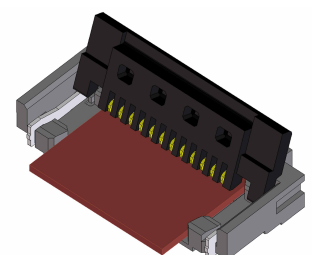
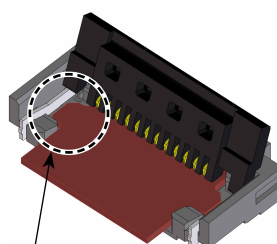

Figure.2

FPC side catcher design

Applicable for tabbed FPC by side catcher design

Applicable for normal FPC/FFC



Stable holding and high retention force of FPC

Figure.3

■ Product Specifications

Rating	Current rating : 0.5A DC (Note 1) Voltage rating : 50V AC	Operating Temperature Range : -40 to +85°C (Note 2) Operating Humidity Range : Relative humidity, 90% max. (Not dewed)	Storage Temperature Range : -10 to +50°C (Note 3) Storage Humidity Range : Relative humidity, 90% max. (Not dewed)

Applicable FPC	t=0.3 ± 0.03 Gold plated
----------------	--------------------------

Item	Specification	Conditions
1. Insulation resistance	500M ohms minimum	100V DC
2. Withstanding voltage	No flashover or insulation breakdown	150V AC/1 minute
3. Contact resistance	50m ohms maximum	1mA
4. Durability (Insertion/withdrawal)	Contact resistance : 50m ohms maximum No damage, cracks, or parts dislocation.	20 cycles
5. Vibration	No electrical discontinuity of 1μs or more Contact resistance : 50m ohms maximum, No damage, cracks, or parts dislocation.	Frequency : 10 to 55 Hz, total amplitude of 1.5mm, 2 hours in each of the 3 directions.
6. Shock	No electrical discontinuity of 1μs or more Contact resistance : 50m ohms maximum, No damage, cracks, or parts dislocation.	Acceleration of 490 m/s ² , 6 ms duration, sine half-waveform, 3 cycles in each of the 3 axis.
7. Humidity (Steady state)	Contact resistance : 50m ohms maximum, Insulation resistance : 50M ohms minimum, No damage, cracks, or parts dislocation.	96 hours at 40°C and humidity of 90% to 95%
8. Temperature Cycle	Contact resistance : 50m ohms maximum, Insulation resistance : 50M ohms minimum, No damage, cracks, or parts dislocation.	Temperature : -40°C → 15 to 35°C → 85°C → 15 to 35°C, Time 30 → 2 to 3 → 30 → 2 to 3 (minutes) 5 cycles
9. Resistance to Soldering heat	No deformation of components affecting performance.	Reflow : At the recommended temperature profile Manual soldering : 350 ± 10°C for 5 seconds

Note 1 : When passing the current through all of the contacts, use 70% of the current rating.

Note 2 : Includes temperature rise caused by current flow.

Note 3 : The term "storage" refers to products stored for long period of time prior to mounting and use. Operating temperature range and Humidity range covers nonconducting condition of installed connectors in storage, shipment or during transportation.

Note 4 : Information contained in this catalog represents general requirements for this series.
Contact us for the drawings and specifications for a specific part number shown.

■ Material

Part	Material	Finish	Remarks
Insulator	LCP	Color : Beige	UL94V-0
Actuator	LCP	Color : Black	
Contact	Phosphor bronze	Gold plated	_____
Metal Fittings	Brass	Tin plated	

■ Ordering Information

TF 31 - 40 (20) S B-1 SH (*)**

①
②
③
④
⑤
⑥
⑦
⑧

① Series Name : TF	⑤ Eccentric direction: Blank : Standard type A, B : Eccentric type
② Series No. : 31	
③ Standard type : Number of contacts Eccentric type : Number of contacts in 0.5mm housing	⑥ Contact Pitch : 0.5mm, 1.0mm
④ Standard type : Blank Eccentric type : Number of contacts	⑦ Contact type SH : SMT horizontal mounting type
	⑧ Plating specification : (800) · Gold plating, 3,000 pieces / reel

■ 0.5mm Pitch Bottom Contact Type

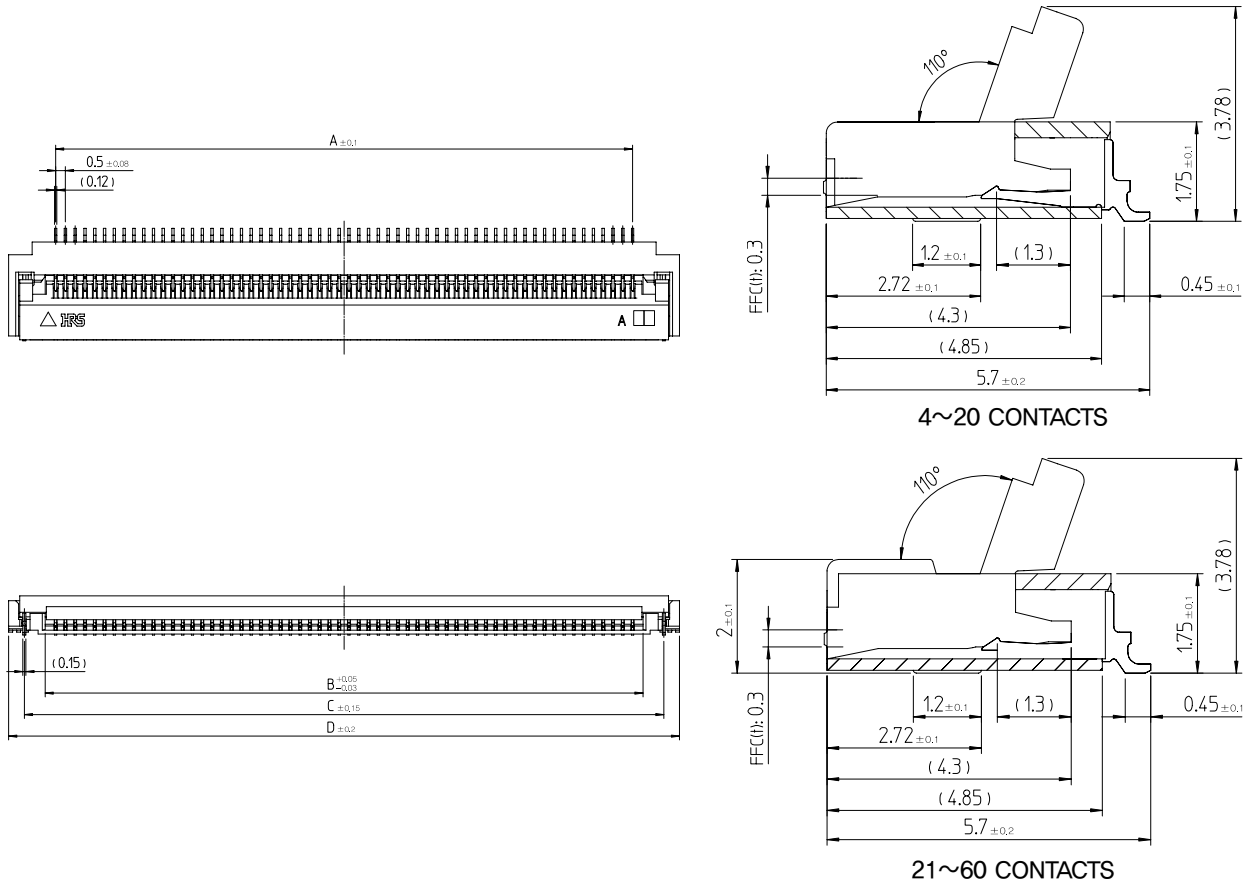

- Note1 : The coplanarity of each terminal lead within specified dimension is 0.1mm Max.
- Note2 : Packaged on tape and reel only. Check packaging specification.
- Note3 : Slight variations in color of the plastic compounds do not affect form, fit or function of the connector.
- Note4 : After reflow, the terminal plating may change color, however this does not represent a quality issue.

Unit : mm

PART NUMBER	CL No.	NUMBER OF CONTACTS	A	B	C	D
TF31-4S-0.5SH(800)	—	4S	1.5	2.57	4.7	6.3
TF31-6S-0.5SH(800)	4800154500	6S	2.5	3.57	5.7	7.3
TF31-8S-0.5SH(800)	4800184600	8S	3.5	4.57	6.7	8.3
TF31-10S-0.5SH(800)	4800130700	10S	4.5	5.57	7.7	9.3
TF31-12S-0.5SH(800)	4800131000	12S	5.5	6.57	8.7	10.3
TF31-13S-0.5SH(800)	4800177000	13S	6.0	7.07	9.2	10.8
TF31-14S-0.5SH(800)	4800155800	14S	6.5	7.57	9.7	11.3
TF31-16S-0.5SH(800)	4800178300	16S	7.5	8.57	10.7	12.3
TF31-17S-0.5SH(800)	4800185900	17S	8.0	9.07	11.2	12.8
TF31-18S-0.5SH(800)	4800161000	18S	8.5	9.57	11.7	13.3
TF31-20S-0.5SH(800)	4800132200	20S	9.5	10.57	12.7	14.3
TF31-21S-0.5SH(800)	4800186100	21S	10.0	11.07	13.2	14.8
TF31-22S-0.5SH(800)	4800143900	22S	10.5	11.57	13.7	15.3
TF31-26S-0.5SH(800)	4800162300	26S	12.5	13.57	15.7	17.3
TF31-28S-0.5SH(800)	4800156000	28S	13.5	14.57	16.7	18.3
TF31-30S-0.5SH(800)	4800179600	30S	14.5	15.57	17.7	19.3
TF31-32S-0.5SH(800)	4800157300	32S	15.5	16.57	18.7	20.3
TF31-35S-0.5SH(800)	—	35S	17.0	18.07	20.2	21.8
TF31-36S-0.5SH(800)	4800163600	36S	17.5	18.57	20.7	22.3
TF31-40S-0.5SH(800)	4800133500	40S	19.5	20.57	22.7	24.3
TF31-45S-0.5SH(800)	4800134800	45S	22.0	23.07	25.2	26.8
TF31-50S-0.5SH(800)	4800135000	50S	24.5	25.57	27.7	29.3
TF31-55S-0.5SH(800)	4800187400	55S	27	28.07	30.2	31.8
TF31-60S-0.5SH(800)	4800136300	60S	29.5	30.57	32.7	34.3

Note1 : Embossed tape reel packaging (3,000pieces/reel).
Order by number of reels.

■ 1.0mm Pitch Bottom Contact Type

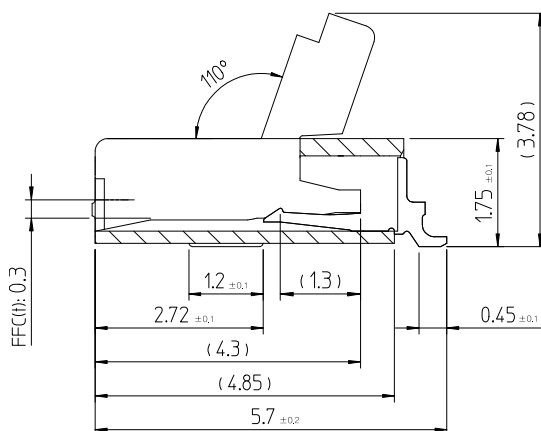
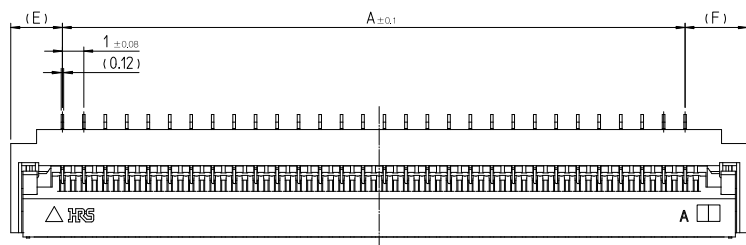

4~8 CONTACTS

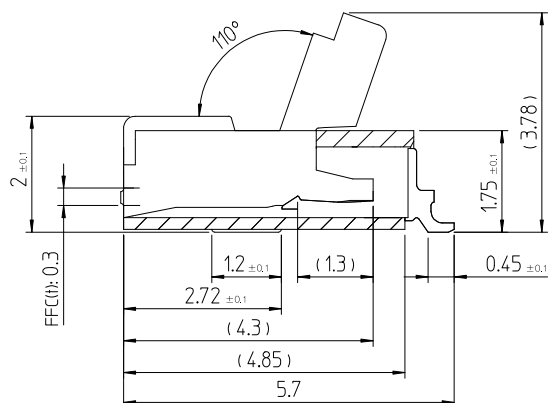
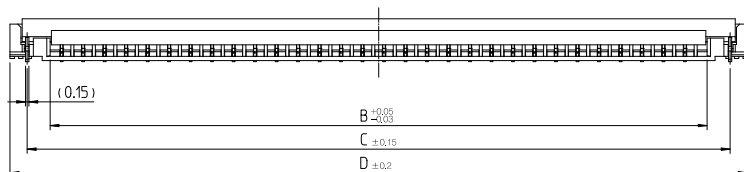

10~30 CONTACTS

Note 1 : The coplanarity of each terminal lead within specified dimension is 0.1mm Max.

Note 2 : Packaged on tape and reel only. Check packaging specification.

Note 3 : Slight variations in color of the plastic compounds do not affect form, fit or function of the connector.

Note 4 : After reflow, the terminal plating may change color, however this does not represent a quality issue.

Unit : mm

PART NUMBER	CL No.	NUMBER OF CONTACTS	A	B	C	D	E	F
TF31-10(4)SA-1SH(800)	4800169200	4S	3.0	5.57	7.7	9.3	2.9	3.4
TF31-6S-1SH(800)	4800168000	6S	5.0	7.07	9.2	10.8	2.9	2.9
TF31-8S-1SH(800)	—	8S	7.0	9.07	11.2	12.8	2.9	2.9
TF31-10S-1SH(800)	—	10S	9.0	11.07	13.2	14.8	2.9	2.9
TF31-40(20)SB-1SH(800)	—	20S	19.0	20.57	22.7	24.3	2.4	2.9
TF31-60(30)SB-1SH(800)	4800180500	30S	29.0	30.57	32.7	34.3	2.4	2.9

Note 1 : Embossed tape reel packaging (3,000pieces/reel).
Order by number of reels.

■ Recommended FPC/FFC dimensions and Land/Metal Mask dimensions

● 0.5mm Pitch Product

	FPC / FFC dimensions	Land / Metal Mask dimensions																																																																																																																																																																																																								
<p>0.5mm Pitch Bottom Contact Type</p>	<p>Unit : mm</p> <table border="1"> <thead> <tr> <th>DIMENSION</th> <th>A</th> <th>B</th> <th>C</th> </tr> </thead> <tbody> <tr><td>4S</td><td>1.5</td><td>2.5</td><td>3.9</td></tr> <tr><td>6S</td><td>2.5</td><td>3.5</td><td>4.9</td></tr> <tr><td>8S</td><td>3.5</td><td>4.5</td><td>5.9</td></tr> <tr><td>10S</td><td>4.5</td><td>5.5</td><td>6.9</td></tr> <tr><td>12S</td><td>5.5</td><td>6.5</td><td>7.9</td></tr> <tr><td>13S</td><td>6.0</td><td>7.0</td><td>8.4</td></tr> <tr><td>14S</td><td>6.5</td><td>7.5</td><td>8.9</td></tr> <tr><td>16S</td><td>7.5</td><td>8.5</td><td>9.9</td></tr> <tr><td>17S</td><td>8.0</td><td>9.0</td><td>10.4</td></tr> <tr><td>18S</td><td>8.5</td><td>9.5</td><td>10.9</td></tr> <tr><td>20S</td><td>9.5</td><td>10.5</td><td>11.9</td></tr> <tr><td>21S</td><td>10.0</td><td>11.0</td><td>12.4</td></tr> <tr><td>22S</td><td>10.5</td><td>11.5</td><td>12.9</td></tr> <tr><td>26S</td><td>12.5</td><td>13.5</td><td>14.9</td></tr> <tr><td>28S</td><td>13.5</td><td>14.5</td><td>15.9</td></tr> <tr><td>30S</td><td>14.5</td><td>15.5</td><td>16.9</td></tr> <tr><td>32S</td><td>15.5</td><td>16.5</td><td>17.9</td></tr> <tr><td>35S</td><td>17.0</td><td>18.0</td><td>19.4</td></tr> <tr><td>36S</td><td>17.5</td><td>18.5</td><td>19.9</td></tr> <tr><td>40S</td><td>19.5</td><td>20.5</td><td>21.9</td></tr> <tr><td>45S</td><td>22.0</td><td>23.0</td><td>24.4</td></tr> <tr><td>50S</td><td>24.5</td><td>25.5</td><td>26.9</td></tr> <tr><td>55S</td><td>27.0</td><td>28.0</td><td>29.4</td></tr> <tr><td>60S</td><td>29.5</td><td>30.5</td><td>31.9</td></tr> </tbody> </table>	DIMENSION	A	B	C	4S	1.5	2.5	3.9	6S	2.5	3.5	4.9	8S	3.5	4.5	5.9	10S	4.5	5.5	6.9	12S	5.5	6.5	7.9	13S	6.0	7.0	8.4	14S	6.5	7.5	8.9	16S	7.5	8.5	9.9	17S	8.0	9.0	10.4	18S	8.5	9.5	10.9	20S	9.5	10.5	11.9	21S	10.0	11.0	12.4	22S	10.5	11.5	12.9	26S	12.5	13.5	14.9	28S	13.5	14.5	15.9	30S	14.5	15.5	16.9	32S	15.5	16.5	17.9	35S	17.0	18.0	19.4	36S	17.5	18.5	19.9	40S	19.5	20.5	21.9	45S	22.0	23.0	24.4	50S	24.5	25.5	26.9	55S	27.0	28.0	29.4	60S	29.5	30.5	31.9	<p>Recommended metal mask thickness : 0.12mm</p> <p>Unit : mm</p> <table border="1"> <thead> <tr> <th>DIMENSION</th> <th>A</th> <th>B</th> <th>C</th> </tr> </thead> <tbody> <tr><td>4S</td><td>1.5</td><td>3.5</td><td>7.3</td></tr> <tr><td>6S</td><td>2.5</td><td>4.5</td><td>8.3</td></tr> <tr><td>8S</td><td>3.5</td><td>5.5</td><td>9.3</td></tr> <tr><td>10S</td><td>4.5</td><td>6.5</td><td>10.3</td></tr> <tr><td>12S</td><td>5.5</td><td>7.5</td><td>11.3</td></tr> <tr><td>13S</td><td>6.0</td><td>8.0</td><td>11.8</td></tr> <tr><td>14S</td><td>6.5</td><td>8.5</td><td>12.3</td></tr> <tr><td>16S</td><td>7.5</td><td>9.5</td><td>13.3</td></tr> <tr><td>17S</td><td>8.0</td><td>10.0</td><td>13.8</td></tr> <tr><td>18S</td><td>8.5</td><td>10.5</td><td>14.3</td></tr> <tr><td>20S</td><td>9.5</td><td>11.5</td><td>15.3</td></tr> <tr><td>21S</td><td>10.0</td><td>12.0</td><td>15.8</td></tr> <tr><td>22S</td><td>10.5</td><td>12.5</td><td>16.3</td></tr> <tr><td>26S</td><td>12.5</td><td>14.5</td><td>18.3</td></tr> <tr><td>28S</td><td>13.5</td><td>15.5</td><td>19.3</td></tr> <tr><td>30S</td><td>14.5</td><td>16.5</td><td>20.3</td></tr> <tr><td>32S</td><td>15.5</td><td>17.5</td><td>21.3</td></tr> <tr><td>35S</td><td>17.0</td><td>19.0</td><td>22.8</td></tr> <tr><td>36S</td><td>17.5</td><td>19.5</td><td>23.3</td></tr> <tr><td>40S</td><td>19.5</td><td>21.5</td><td>25.3</td></tr> <tr><td>45S</td><td>22.0</td><td>24.0</td><td>27.8</td></tr> <tr><td>50S</td><td>24.5</td><td>26.5</td><td>30.3</td></tr> <tr><td>55S</td><td>27.0</td><td>29.0</td><td>32.8</td></tr> <tr><td>60S</td><td>29.5</td><td>31.5</td><td>35.3</td></tr> </tbody> </table>	DIMENSION	A	B	C	4S	1.5	3.5	7.3	6S	2.5	4.5	8.3	8S	3.5	5.5	9.3	10S	4.5	6.5	10.3	12S	5.5	7.5	11.3	13S	6.0	8.0	11.8	14S	6.5	8.5	12.3	16S	7.5	9.5	13.3	17S	8.0	10.0	13.8	18S	8.5	10.5	14.3	20S	9.5	11.5	15.3	21S	10.0	12.0	15.8	22S	10.5	12.5	16.3	26S	12.5	14.5	18.3	28S	13.5	15.5	19.3	30S	14.5	16.5	20.3	32S	15.5	17.5	21.3	35S	17.0	19.0	22.8	36S	17.5	19.5	23.3	40S	19.5	21.5	25.3	45S	22.0	24.0	27.8	50S	24.5	26.5	30.3	55S	27.0	29.0	32.8	60S	29.5	31.5	35.3
	DIMENSION	A	B	C																																																																																																																																																																																																						
4S	1.5	2.5	3.9																																																																																																																																																																																																							
6S	2.5	3.5	4.9																																																																																																																																																																																																							
8S	3.5	4.5	5.9																																																																																																																																																																																																							
10S	4.5	5.5	6.9																																																																																																																																																																																																							
12S	5.5	6.5	7.9																																																																																																																																																																																																							
13S	6.0	7.0	8.4																																																																																																																																																																																																							
14S	6.5	7.5	8.9																																																																																																																																																																																																							
16S	7.5	8.5	9.9																																																																																																																																																																																																							
17S	8.0	9.0	10.4																																																																																																																																																																																																							
18S	8.5	9.5	10.9																																																																																																																																																																																																							
20S	9.5	10.5	11.9																																																																																																																																																																																																							
21S	10.0	11.0	12.4																																																																																																																																																																																																							
22S	10.5	11.5	12.9																																																																																																																																																																																																							
26S	12.5	13.5	14.9																																																																																																																																																																																																							
28S	13.5	14.5	15.9																																																																																																																																																																																																							
30S	14.5	15.5	16.9																																																																																																																																																																																																							
32S	15.5	16.5	17.9																																																																																																																																																																																																							
35S	17.0	18.0	19.4																																																																																																																																																																																																							
36S	17.5	18.5	19.9																																																																																																																																																																																																							
40S	19.5	20.5	21.9																																																																																																																																																																																																							
45S	22.0	23.0	24.4																																																																																																																																																																																																							
50S	24.5	25.5	26.9																																																																																																																																																																																																							
55S	27.0	28.0	29.4																																																																																																																																																																																																							
60S	29.5	30.5	31.9																																																																																																																																																																																																							
DIMENSION	A	B	C																																																																																																																																																																																																							
4S	1.5	3.5	7.3																																																																																																																																																																																																							
6S	2.5	4.5	8.3																																																																																																																																																																																																							
8S	3.5	5.5	9.3																																																																																																																																																																																																							
10S	4.5	6.5	10.3																																																																																																																																																																																																							
12S	5.5	7.5	11.3																																																																																																																																																																																																							
13S	6.0	8.0	11.8																																																																																																																																																																																																							
14S	6.5	8.5	12.3																																																																																																																																																																																																							
16S	7.5	9.5	13.3																																																																																																																																																																																																							
17S	8.0	10.0	13.8																																																																																																																																																																																																							
18S	8.5	10.5	14.3																																																																																																																																																																																																							
20S	9.5	11.5	15.3																																																																																																																																																																																																							
21S	10.0	12.0	15.8																																																																																																																																																																																																							
22S	10.5	12.5	16.3																																																																																																																																																																																																							
26S	12.5	14.5	18.3																																																																																																																																																																																																							
28S	13.5	15.5	19.3																																																																																																																																																																																																							
30S	14.5	16.5	20.3																																																																																																																																																																																																							
32S	15.5	17.5	21.3																																																																																																																																																																																																							
35S	17.0	19.0	22.8																																																																																																																																																																																																							
36S	17.5	19.5	23.3																																																																																																																																																																																																							
40S	19.5	21.5	25.3																																																																																																																																																																																																							
45S	22.0	24.0	27.8																																																																																																																																																																																																							
50S	24.5	26.5	30.3																																																																																																																																																																																																							
55S	27.0	29.0	32.8																																																																																																																																																																																																							
60S	29.5	31.5	35.3																																																																																																																																																																																																							
<p>1.0mm Pitch Bottom Contact Type</p>	<p>Unit : mm</p> <table border="1"> <thead> <tr> <th>DIMENSION</th> <th>A</th> <th>B</th> <th>C</th> <th>D</th> <th>E</th> </tr> </thead> <tbody> <tr><td>4S</td><td>3.0</td><td>5.5</td><td>6.9</td><td>1.0</td><td>1.5</td></tr> <tr><td>6S</td><td>5.0</td><td>7.0</td><td>8.4</td><td>1.0</td><td>1.0</td></tr> <tr><td>8S</td><td>7.0</td><td>9.0</td><td>10.4</td><td>1.0</td><td>1.0</td></tr> <tr><td>10S</td><td>9.0</td><td>11.0</td><td>12.4</td><td>1.0</td><td>1.0</td></tr> <tr><td>20S</td><td>19.0</td><td>20.5</td><td>21.9</td><td>0.5</td><td>1.0</td></tr> <tr><td>30S</td><td>29.0</td><td>30.5</td><td>31.9</td><td>0.5</td><td>1.0</td></tr> </tbody> </table>	DIMENSION	A	B	C	D	E	4S	3.0	5.5	6.9	1.0	1.5	6S	5.0	7.0	8.4	1.0	1.0	8S	7.0	9.0	10.4	1.0	1.0	10S	9.0	11.0	12.4	1.0	1.0	20S	19.0	20.5	21.9	0.5	1.0	30S	29.0	30.5	31.9	0.5	1.0	<p>Recommended metal mask thickness : 0.12mm</p> <p>Unit : mm</p> <table border="1"> <thead> <tr> <th>DIMENSION</th> <th>A</th> <th>B</th> <th>C</th> <th>D</th> <th>E</th> </tr> </thead> <tbody> <tr><td>4S</td><td>3.0</td><td>6.5</td><td>10.3</td><td>1.5</td><td>2.0</td></tr> <tr><td>6S</td><td>5.0</td><td>8.0</td><td>11.8</td><td>1.5</td><td>1.5</td></tr> <tr><td>8S</td><td>7.0</td><td>10.0</td><td>13.8</td><td>1.5</td><td>1.5</td></tr> <tr><td>10S</td><td>9.0</td><td>12.0</td><td>15.8</td><td>1.5</td><td>1.5</td></tr> <tr><td>20S</td><td>19.0</td><td>21.5</td><td>25.3</td><td>1.0</td><td>1.5</td></tr> <tr><td>30S</td><td>29.0</td><td>31.5</td><td>35.3</td><td>1.0</td><td>1.5</td></tr> </tbody> </table>	DIMENSION	A	B	C	D	E	4S	3.0	6.5	10.3	1.5	2.0	6S	5.0	8.0	11.8	1.5	1.5	8S	7.0	10.0	13.8	1.5	1.5	10S	9.0	12.0	15.8	1.5	1.5	20S	19.0	21.5	25.3	1.0	1.5	30S	29.0	31.5	35.3	1.0	1.5																																																																																																																				
DIMENSION	A	B	C	D	E																																																																																																																																																																																																					
4S	3.0	5.5	6.9	1.0	1.5																																																																																																																																																																																																					
6S	5.0	7.0	8.4	1.0	1.0																																																																																																																																																																																																					
8S	7.0	9.0	10.4	1.0	1.0																																																																																																																																																																																																					
10S	9.0	11.0	12.4	1.0	1.0																																																																																																																																																																																																					
20S	19.0	20.5	21.9	0.5	1.0																																																																																																																																																																																																					
30S	29.0	30.5	31.9	0.5	1.0																																																																																																																																																																																																					
DIMENSION	A	B	C	D	E																																																																																																																																																																																																					
4S	3.0	6.5	10.3	1.5	2.0																																																																																																																																																																																																					
6S	5.0	8.0	11.8	1.5	1.5																																																																																																																																																																																																					
8S	7.0	10.0	13.8	1.5	1.5																																																																																																																																																																																																					
10S	9.0	12.0	15.8	1.5	1.5																																																																																																																																																																																																					
20S	19.0	21.5	25.3	1.0	1.5																																																																																																																																																																																																					
30S	29.0	31.5	35.3	1.0	1.5																																																																																																																																																																																																					

■ Packaging Specification

● Embossed Carrier Tape Dimensions

Tape width 24mm max.

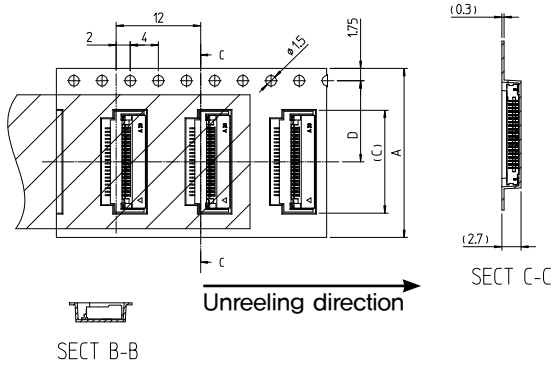

Tape width 32mm min.

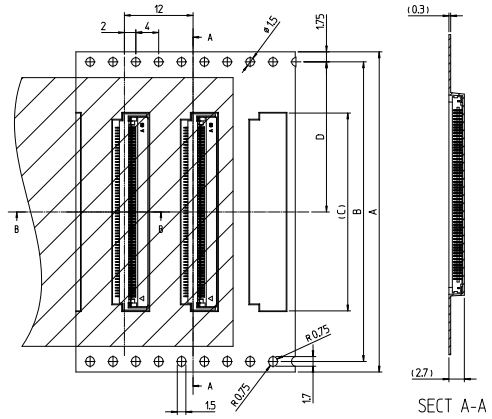

● Reel Dimensions

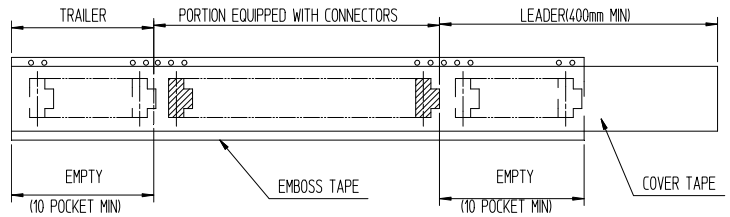
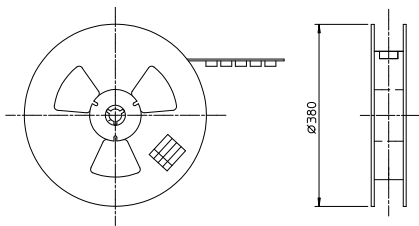

Note 1 : 1 REEL CONTAINS 3,000PCS.

Note 2 : MATERIAL

- 1) EMBOSS TAPE : Tape width 24mm MAX : PS (ANTISTATIC TREATMENT)
Tape width 36mm MIN : PET (ANTISTATIC TREATMENT)
- 2) COVER TAPE : PET (ANTISTATIC TREATMENT)

[0.5mm PITCH]

Unit : mm

DIMENSION NUMBER OF CONTACTS	DIMENSION			
	A	B	C	D
4S	16	—	6.6	7.5
6S	16	—	7.6	7.5
8S	16	—	8.6	7.5
10S	16	—	9.6	7.5
12S	24	—	10.6	11.5
13S	24	—	11.1	11.5
14S	24	—	11.6	11.5
16S	24	—	12.6	11.5
17S	24	—	13.1	11.5
18S	24	—	13.6	11.5
20S	24	—	14.6	11.5
21S	32	28.4	15.1	14.2
22S	32	28.4	15.6	14.2
26S	32	28.4	17.6	14.2
28S	32	28.4	18.6	14.2
30S	32	28.4	19.6	14.2
32S	32	28.4	20.6	14.2
35S	44	40.4	22.1	20.2
36S	44	40.4	22.6	20.2
40S	44	40.4	24.6	20.2
45S	44	40.4	27.1	20.2
50S	44	40.4	29.6	20.2
60S	56	52.4	34.6	26.2

[1.0mm PITCH]

Unit : mm

DIMENSION NUMBER OF CONTACTS	DIMENSION			
	A	B	C	D
4S	16	—	9.6	7.5
6S	24	—	11.1	11.5
8S	24	—	13.1	11.5
10S	32	28.4	15.1	14.2
20S	44	40.4	24.6	20.2
30S	56	52.4	34.6	26.2

■ TF31 Series FPC/FFC Construction (Recommended Specifications)

1.FFC

FFC : Flexible Flat Cable

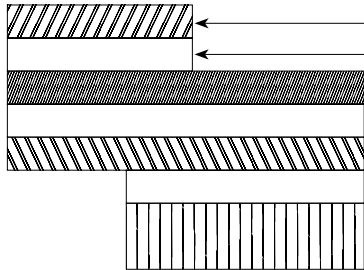

Material Name	Material	Thickness (μm)
Polyester film		(12)
Adhesive	Polyester thermoplastic type	(30)
Annealed copper foil (gold-plated nickel)		35
Adhesive	Polyester type	30
Polyester		12
Adhesive	Polyester type	30
Stiffener	Polyester type	188
Total		295

2.FPC

FPC : Flexible Printed Circuit

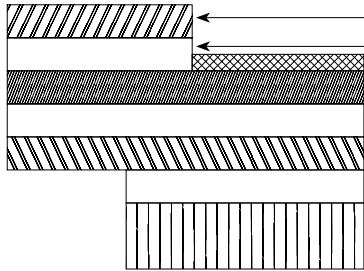

Material Name	Material	Thickness (μm)
Covering layer film	Polyamide 1mil	(25)
Cover adhesive		(25)
Surface treatment	Nicker 1~5μm + gold plating 0.2μm	3
Copper foil	Cu 1oz	35
Base adhesive	Thermoset adhesive	25
Base film	Polyamide 1mil	25
Stiffener	Thermoset adhesive	30
Stiffener	Polyamide 7mil	175
Total		293

3.Precautions

1. This specification is a recommendation for the construction of the TF31 Series FPC and FFC ($t=0.3 \pm 0.03$).
2. For details about the construction, please contact the FPC/FFC manufacturers.

■ Recommended Temperature Profile

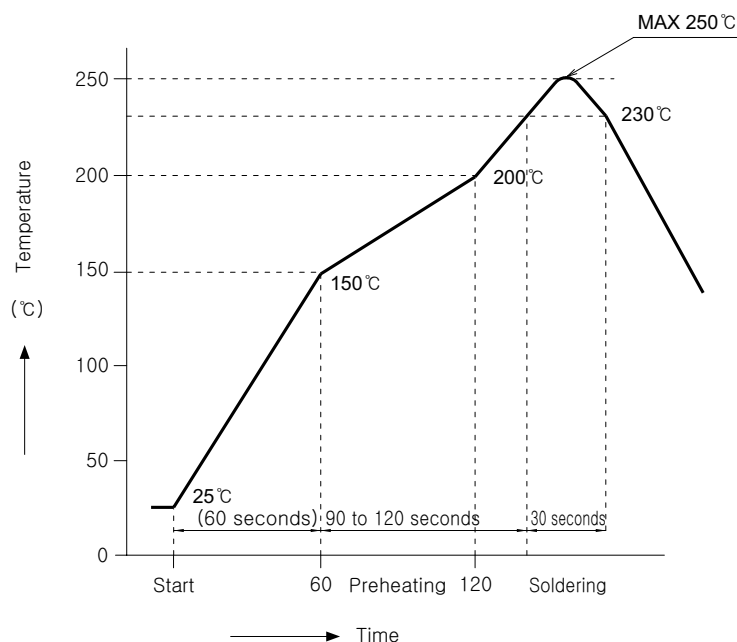

HRS test conditions

Solder method	: Reflow, IR/hot air
Environment	: Room air
Solder composition	: Paste, 96.5%Sn/3%Ag/0.5%Cu (Senju Metal Industry, Co., Ltd.'s Part Number: M705-221CM5-32-10.5)
Test board	: Glass epoxy 40mm×80mm×1.6mm thick
Land dimensions	: 0.3mm×1.3mm
Metal mask	: 0.3mm×1.3mm×0.12mm thick

The temperature profile provided was based on the conditions explained above. In each individual application the actual temperature may vary depending on the volume/thickness of solder paste type, and the size/thickness of the board. Please contact the manufacturer of the solder paste and the equipment manufacturer for their specific recommendations.

■ Connector Operating Instructions, precautions and recommendations

● Bottom Contact Type (common for 0.5mm/1mm Pitch)

INSTRUCTIONS FOR MOUNTING ON THE BOARD

◆ Board Distortion

Be sure to minimize the board distortion as much as possible. The lead co-planarity is 0.1 mm or less, and includes the reinforced metal fittings. If the board becomes too warped or distorted this may result in a soldering failures and co-planarity issues.

◆ Connector Load

If the connector is not mounted onto a board, refrain from doing any of the following actions: Do not apply a force of 1 N or more to the connector. Do not insert the FFC or operate the connector. Any of these actions may damage or break the connector.

◆ Board stress

It may advisable to split larger boards into smaller sections to reduce overall board stress. Avoid placing any excess force on the board during the assembly process. When using screws to secure the boards, be sure to check for any unwanted stress that may occur from this operation as well.

◆ Acceptable amount of board deflection

A 100 mm wide board has an acceptable warp range of 1 mm or less. Excessive amounts of warping will place stress on the connector which will damage the connector and cause malfunction.

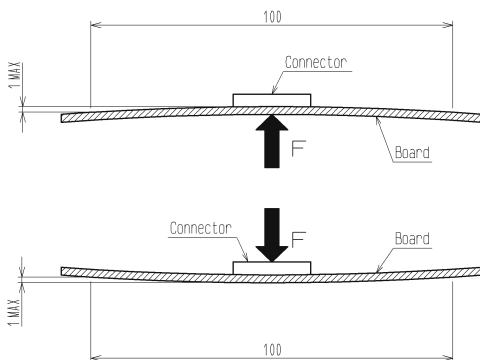

INSTRUCTIONS ON INSERTING FFC/FPC AND CONNECTION

◆ Actuator precautions and Handling instructions

1. Do not apply excessive force on the actuator when releasing it from its initial position. If you use your nail or finger as shown below, the terminals might become deformed.

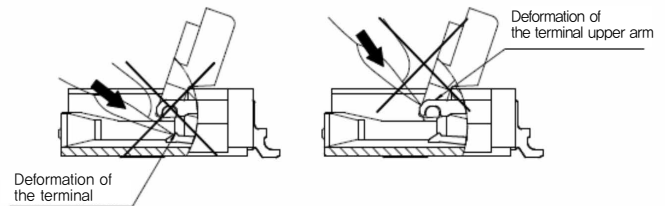

2. The actuator rotates around an axis as shown below. Make sure to rotate the whole actuator and not just the center portion.
3. The actuator opens up to 110°. Do not force the actuator beyond this point. Doing so may damage or break off the actuator.
4. Rotate the whole actuator downward and not just the center portion.
5. Do not pull or pick at the actuator as shown below, doing so may damage it. (Do not carry out any operation other than rotating the actuator.)

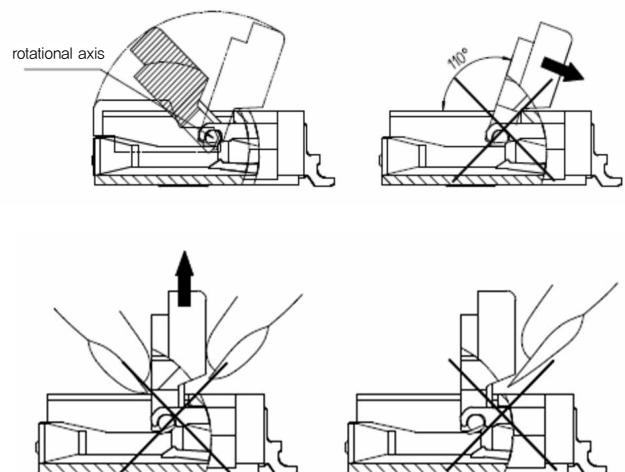

◆ Contact orientation

This connector utilizes bottom contacts. Insert the FFC/FPC with the exposed conductors face down.

◆ **Inserting the FFC/FPC**

1. Insert the FFC/FPC straight into the connector, but at a 10° angle (see illustration below). Make sure that it has been fully inserted.

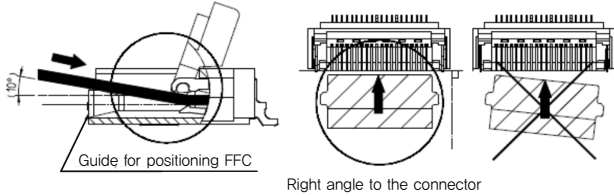

2. Do not insert the FFC/FPC in a diagonal manner. If the FFC/FPC is inserted in skewed orientation as illustrated above, the FFC/FPC may be caught by the terminals resulting in deformation of the terminals.

※Design the correct layout for these parts. Doing so will allow for sufficient space to properly insert the FFC/ FPC to its proper position and depth. Consult with your FPC/FFC manufacturer to select a flex circuit that has the correct flex characteristics to avoid breakage.

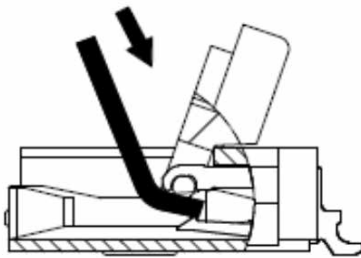

3. Do not try to operate the actuator until the FFC/ FPC has been correctly positioned into the connector. If the FFC/FPC is sitting on the guides, using the actuator may damage the connector.

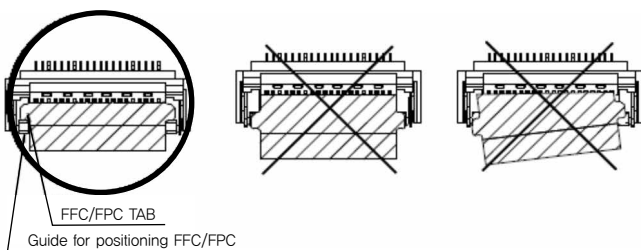

◆ **Ensuring a completed connection**

After completing the locking operation, be sure to check that the actuator is horizontal to the board surface. Use caution when checking the actuator. Do not apply excessive force, doing so may damage the terminals.

Instructions on FFC/FPC layout after connection

◆ **Load to FFC/FPC**

Do not apply direct force to the connector after inserting the FFC/FPC. Doing so may lead to the connector becoming unlocked or damage to the FFC/ FPC. In general the FFC/FPC should not be bent sharply near the insertion opening. Sharps bends can cause malfunction and a disrupted connection.

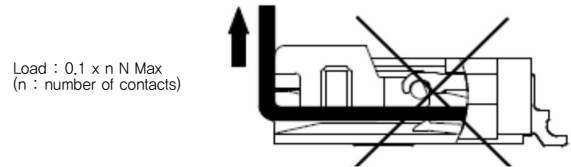

Instructions on removing FFC/FPC

- ◆ **Rotate the whole actuator upward and not just the center portion.**
- ◆ **Pull the FFC/FPC straight out of the connector at a 10° angle.**

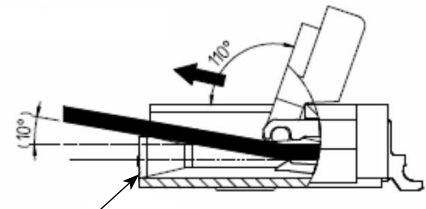

Other instructions

◆ **Instructions on Manual Soldering**

Follow the instructions shown below when soldering the connector manually during repair work, etc.

1. Do not perform reflow soldering or manual soldering with the FFC inserted into the connector.
2. Do not overheat the connector. Do not allow the soldering iron to contact any part other than the intended connector leads. Unnecessary contact may lead to damage and deformities of the connector.
3. Do not use excessive solder (or flux). If excessive solder (or flux) is used on the terminals, solder or flux may adhere to the contacts or rotating parts of the actuator, resulting in poor contact or a rotation failure of the actuator. Supplying excessive solder to the reinforcing bracket may hinder actuator rotation, resulting in breakage of the connector.
4. Do not use excessive solder (flux) on these connectors. Doing so may result in poor contact performance, malfunctioning actuators / reinforcing brackets due to the excessive solder and may ultimately lead to a broken connector.

USA:
HIROSE ELECTRIC (U.S.A), INC. Headquarters
2688 Westhills Court, Simi Valley, CA 93065-6235
Phone : 1-805-522-7958
Fax : 1-805-522-3217
<http://www.hiroseusa.com>

USA:
HIROSE ELECTRIC (U.S.A), INC. San Jose Office
3255 Scott Boulevard, Building 7, Suite 101 Santa Clara, CA 95054
Phone : 1-408-253-9640
Fax : 1-408-253-9641
<http://www.hiroseusa.com>

USA:
HIROSE ELECTRIC (U.S.A), INC. Detroit Office (Automotive)
37677 Professional Center Drive, Suite #100C Livonia, MI 48154
Phone : 1-734-542-9963
Fax : 1-734-542-9964
<http://www.hiroseusa.com>

GERMANY:
HIROSE ELECTRIC EUROPE B.V. GERMAN BRANCH
Herzog-Carl-Strasse 4 D-73760 Ostfildern (Scharnhäuser Park)
Phone : 49-711-4560-02-1
Fax : 49-711-4560-02-299
<http://www.hirose.de>

THE NETHERLANDS:
HIROSE ELECTRIC EUROPE B.V.
Hogehillweg #8 1101 CC Amsterdam Z-O
Phone : 31-20-6557460
Fax : 31-20-6557469
<http://www.hiroseeurope.com>

UNITED KINGDOM:
HIROSE ELECTRIC EUROPE B.V. UK Branch
22 Vincent Avenue, Crownhill Business Centre, Crownhill, Milton Keynes, MK8 0AB.
Phone : 44-1908-305750
Fax : 44-1908-305768
<http://www.hirose.co.uk>

CHINA:BEIJING
HIROSE ELECTRIC (SHANGHAI) CO.,LTD. BEIJING BRANCH
A1001, Ocean International Center, Building 56# East 4th Ring Middle Road, Chao Yang District, Beijing, 100025
Phone : 86-10-5165-9332
Fax : 86-10-5908-1381
<http://www.hirose-china.com.cn>

CHINA:SHANGHAI
HIROSE ELECTRIC (SHANGHAI) CO.,LTD.
1601, Henderson Metropolitan, No.300, East Nanjing Road, Huangqu District, Shanghai, China 200001
Phone : 86-21-6391-3355
Fax : 86-21-6391-3335
<http://www.hirose-china.com.cn>

CHINA:SHENZHEN
HIROSE ELECTRIC TECHNOLOGIES (SHENZHEN) CO.,LTD.
Room 09-13, 19/F, Office Tower Shun Hing Square, Di Wang Commercial Center, 5002 Shen Nan Dong Road, ShenZhen City, Guangdong Province, 518008
Phone : 86-755-8207-0851
Fax : 86-755-8207-0873
<http://www.hirose-china.com.cn>

HONG KONG:
HIROSE ELECTRIC HONGKONG TRADING CO.,LTD.
Unit 1102 A&B, Energy Plaza, 92 Granville Road, Tsim Sha Tsui East, Kowloon
Phone : 852-2803-5338
Fax : 852-2591-6560
<http://www.hirose-hongkong.com.hk>

TAIWAN:
HIROSE ELECTRIC TAIWAN CO.,LTD.
103 8F, No.87, Zhengzhou Rd., Taipei
Phone : 886-2-2555-7377
Fax : 886-2-2555-7350
<http://www.hirose-taiwan.com.tw>

KOREA:
HIROSE KOREA CO.,LTD
1261-10, Jeungwhang-Dong, Shihung-City, Kyunggi-Do 429-450
Phone : 82-31-496-7000,7124
Fax : 82-31-498-7100
<http://www.hirose.co.kr>

SINGAPORE:
HIROSE ELECTRIC CO.,LTD.
10 Anson Road #26-16 International Plaza 079903
Phone : 65-6324-6113
Fax : 65-6324-6123
<http://www.hirose-singapore.com.sg>

SINGAPORE:
HIROSE ELECTRIC SINGAPORE PTE. LTD.
10 Anson Road #26-1 International Plaza 079903
Phone : 65-6324-6113
Fax : 65-6324-6123
<http://www.hirose-singapore.com.sg>



HIROSE ELECTRIC CO.,LTD.

5-23,OSAKI 5-CHOME,SHINAGAWA-KU,TOKYO 141-8587,JAPAN
PHONE: 81-3-3491-5300, FAX: 81-3-3495-5230
<http://www.hirose.com>
<http://www.hirose-connectors.com>